



**Zeta C710**  
**Low Power & Fanless IPC**  
**User Guide**

Document Reference: Product User Guide  
Document Issue: 1.0

## Contents

Copyright .....	3
Limitations of Liability .....	3
Trademarks .....	3
Regulatory Statements .....	4
Safety Warning for North America .....	4
Manual Organisation .....	5
Product Overview .....	6
Specification .....	7
General Precautions .....	8
PS/2 Devices .....	8
Electro-Static Discharges .....	8
On-Board Battery .....	8
BIOS & CMOS Memory .....	9
Electromagnetic Compatibility .....	9
Quick Start .....	10
External Connections .....	11
Chassis Cover Removal .....	12
Internal Connections .....	13
CMOS Battery .....	13
Changing System Memory .....	13
Changing Compact Flash .....	15
Changing HDD .....	15
Changing miniPCI Module .....	16
Optional Audio/GPIO Connection .....	16
Internal PSU Options .....	17
Mounting Arrangements .....	19
Outline Drawings .....	20
Permitted Orientations .....	22
System Software .....	23
Operating System Install .....	23
GPIO Software Programming .....	23
Watchdog Timer .....	24
System BIOS .....	25
BIOS Menus .....	25
Main Menu .....	26
Standard CMOS Feature .....	26
Advanced BIOS Features .....	27
Advanced Chipset Features .....	27
Integrated Peripherals .....	28
Power Management Setup .....	30
PnP/PCI Configuration .....	30
Default Settings .....	31
Maintenance .....	32
Amendment History .....	33

## Copyright

All rights reserved. No part of this publication may be reproduced, stored in any retrieval system, or transmitted, in any form or by any means, electronic, mechanical, photocopied, recorded or otherwise, without the prior permission, in writing, from the publisher. For permission in the UK please contact Blue Chip Technology.

Information offered in this manual is believed to be correct at the time of printing. Blue Chip Technology accepts no responsibility for any inaccuracies. The information contained herein is subject to change without notice. There are no express or implied licences granted herein to any intellectual property rights of Blue Chip Technology Ltd.

## Limitations of Liability

In no event shall Blue Chip Technology be held liable for any loss, expenses or damages of any kind whatsoever, whether direct, indirect, incidental or consequential, arising from the design or use of this product or the support materials supplied with this product. If this product proves to be defective, Blue Chip Technology is only obliged to replace or refund the purchase price at Blue Chip Technology's discretion according to their Terms and Conditions of Sale.

## Trademarks

All trademarks and registered names acknowledged.

IBM, PC, AT and PS/2 are trademarks of International Business Machines Corporation (IBM).

VIA is a registered trademark of VIA Technologies, Inc

Phoenix-Award is a registered trademark of Phoenix Technologies LTD.

MSDOS and WINDOWS are registered trademarks of the Microsoft Corporation.

## Regulatory Statements

### CE

This product meets the essential protection requirements of the European EMC Directive (2004/108/EC) and the Low Voltage Directive (2006/95/EC), and is eligible to bear the CE mark.

**Warning**

This is a Class A product. In a domestic environment this product may cause radio interference in which case the user may be required to take adequate measures.

### FCC

#### NOTE:

This equipment has been tested and found to comply with the limits for a Class A digital device, pursuant to Part 15 of the FCC Rules. These limits are designed to provide reasonable protection against harmful interference when the equipment is operated in a commercial environment. This equipment generates, uses, and can radiate radio frequency energy and if not installed and used in accordance with the instruction manual, may cause harmful interference to radio communications. Operation of this equipment in a residential area is likely to cause harmful interference in which case the user will be required to correct the interference at his own expense.

#### WARNING:

Changes or modifications not expressly approved by the manufacturer could void the user's authority to operate the equipment.

## Safety Warning for North America

If the power lead (cord) is not supplied with the computer, select a power lead according to your local electrical regulations. In the USA use a 'UL listed' lead. In Canada use a CSA approved or 'cUL listed' lead.

Si le cordon secteur n'est pas livré avec l'ordinateur, utiliser un cordon secteur en accord avec votre code électrique nationale. En l'Etat Unis utiliser un cordon secteur 'UL listed'. En Canada utiliser un cordon secteur certifié CSA, ou 'cUL listed'.

## Manual Organisation

This manual describes the Zeta C710 Low Power Industrial PC from Blue Chip Technology.

We have tried to include as much information as possible but we have not duplicated information that is provided in the standard IBM Technical References, unless it proved to be necessary to aid in the understanding of the product.

The manual is sectioned as follows:

- Introduction;
- Overview, listing the unit's features and specification;
- Precautions required
- Quick Start guide
- Hardware installation, connection details and upgrades
- Software Configuration
- Bios Setup
- Maintenance

We strongly recommend that you study this manual carefully before attempting to interface with the ZETA C710 or change the standard configurations. Whilst all the necessary information is available in this manual we would recommend that unless you are confident, you contact your supplier for guidance.

***IT IS PARTICULARLY IMPORTANT THAT YOU READ THE SECTION 'PRECAUTIONS' BEFORE HANDLING ANY COMPONENTS INSIDE THE UNIT.***

If you have any suggestions or find any errors concerning this manual and want to inform us of these, please contact our Technical Services department with the relevant details.

## Product Overview

The Zeta range of low power embedded PC's offer a small footprint, application ready solution ideally suited to a variety of industry automation applications such as logistics, data acquisition and access control.

The Zeta C710 has been designed for high electromagnetic compatibility, shock and vibration resistance and is ideal in industrial environments. All electronic components are protected and sealed inside a robust, compact chassis. Fanless operation and an onboard watchdog further enhance system reliability

Powered by a 1.5GHz Via C7 processor, this embedded computer combines performance with low power. A comprehensive feature list includes multiple Serial COM and USB ports and LAN port.

The Zeta C710 offers a variety of configuration options, making it an extremely versatile platform.

Onboard options offer user configurable GPIO or AC'97 compatible audio. Using its miniPCI expansion, there is a choice of additional 10/100 LAN, WiFi LAN or Serial COM Ports. With the Serial port option, this gives a maximum offering of eight serial ports on a small footprint.

Mounting options for the Zeta C710 are also flexible. By addition of feet, the unit can be used as a standard desktop PC. Optional brackets exist for wall mounting or DIN rail mounting.

The Zeta C710 requires 12V DC for operation, or optionally a wide ranging DC power module can be fitted which accepts input voltages between 6V and 26V.

## Specification

CPU:	VIA C7 1.5Ghz
Chipset:	VIA CX700
Graphics Controller:	Integrated into VIA CX700 RGB VGA Output, Maximum resolution 2048x1536 @75Hz
BIOS:	4Mb Flash EEPROM with LAN Boot, PnP, ACPI
Memory:	One x 200-Pin DDR2 SODIMM Socket Supports up to 1GB 533Mhz DDR2 memory modules
LAN:	Realtek 8100BL , supporting 10/100Mb rates
Audio:	Optional Realtek AC'97 codec Mic-In, Line-In, Line-Out
Expansion:	One mini-PCI socket
Primary Storage:	Option from either One 2½" SATA hard disk drive Or One Type II Compact Flash
GPIO:	Optional 16 Digital I/O non-isolated channels 8 input and 8 output
External I/O: Fixed	PS/2 Keyboard and PS/2 Mouse via Splitter cable Standard VGA Connector RJ-45 10/100Mb Base-T Ethernet LAN connector 4 x 9-way Serial Connectors, 4 x RS-232 3 x USB 2.0 connectors
External I/O: Optional	4 x 9-way Serial Connectors (via mini-PCI) (2 x RS232/422/485) Wireless LAN (Via mini-PCI) RJ-45 10/100Mb Base-T Ethernet LAN connector (via miniPCI) 16 Channel GPIO Audio MIC-In, Line-In, Line-Out
Indicators:	Power On LED, Hard Drive Activity LED
Control:	Power Standby push button switch
Watchdog:	Programmable timer, 1-255 seconds
Power Requirements	Standard: 12V DC ±5%-Input, nominally 35W via 2.5/5.5mm Jack Optional: Wide Range 6-26V DC-Input
Environmental Conditions:	Operating temperature range +0°C to +45°C in free air Storage temperature range -20°C to +70°C Relative humidity 10-85% non-condensing Shock and vibration compatible with Light Industrial Usage
Construction:	Painted Aluminium fabrication
Dimensions	210x 172 x 75 mm, excluding the mounting brackets

## General Precautions

Your Industrial PC is susceptible to damage by electrostatic discharges. In order to avoid damage, you should work at an anti-static bench and observe normal anti-static precautions. Wear an anti-static wrist strap connected to an earth point *before* opening any packaging.

Where a wrist strap is not available, discharge any static charge you may have built-up by touching an earth point. Avoid any further movement that could build up another static charge. Touch an earth point from time to time to avoid further build-up, and remove the items from their anti-static bags only when required

### PS/2 Devices

It is important that PS/2 devices (mouse and keyboard) are not connected or disconnected with the unit powered on. Damage or data corruption may occur if this precaution is not observed.

### Electro-Static Discharges

If you are going to open up the unit, it is important to realise that the devices on the cards within this unit can be damaged by static electricity. Bear in mind that the damage caused by static electricity may vary from total destruction to partial damage, which may not be immediately obvious. This could have an effect on the product's reliability and warranty. Before opening the chassis, ensure that you take necessary static precautions. Ideally you should work at an anti-static bench and wear an approved wrist strap or if that is not possible, touch a suitable ground to discharge any static build up before touching the electronics. This should be repeated if the handling continues for any length of time.

If it is necessary to remove a board or electronic assembly, place it into an anti-static bag. This will prevent any static electricity build up damaging the board. Metallised bags are preferred. Do not use black anti-static bags for any item containing a battery because these tend to be conductive and will discharge the battery.

### On-Board Battery

The processor board is fitted with a Lithium battery. Great care should be taken with this type of battery. If the battery is mistreated in any way there is a very real possibility of fire, explosion, and personal harm. Under NO circumstances should it be short-circuited, exposed to temperatures in excess of 100°C or burnt, immersed in water, recharged or disassembled.

Expired batteries remain hazardous and must be disposed of in a safe manner, according to local regulations.

Le panneau de processeur est équipé d'une batterie de lithium. Le grand soin devrait être pris avec ce type de batterie. Si la batterie est mistreated il y a de dans de toute façon un possibility très vrai du feu, d'explosion et de mal personnel. Dans au cunes circonstances il est sous peu circuité, exposé aux températures au dessus de 100 degrés de centigrade ou brûlé, immergé dans l'eau, rechargée ou dissassembled.

Les batteries expirées restent dazaedous et doivent être reejetées d'une façon sûre, selon des règlements locaux.

## **BIOS & CMOS Memory**

Please be aware that with personal computer products, it is possible to create configurations within the CMOS memory that make booting impossible. If this should happen, clear the CMOS settings; (see the description of the Jumper Settings for details).

## **Electromagnetic Compatibility**

This product has been assessed operating in representative, standard configurations. As with any PC product, however, final installation & configuration can vary significantly, and so the following guidelines are offered to help ensure that compatibility is maintained.

- All components added to a system should either carry appropriate equivalent levels of compliance, or be tested for compliance as part of the final system, and should be installed in accordance with supplier recommendations.
- The external enclosure should be securely fastened (with standard lids and covers in place) to ensure good metal-to-metal contact around the internal electronics
- Any metal back plate must be securely screwed to the chassis of the computer to ensure good metal-to-metal (i.e. earth) contact.
- Metal, screened, connector bodies should be securely connected to the enclosure.
- The external cabling to boards causes most EMC problems. It is recommended that any external cabling to the board be totally screened, and that the screen of the cable connects to the metal end bracket of the board or the enclosure and hence to earth. Round, screened cables with a braided wire screen are used in preference to those with a foil screen and drain wire. Wherever possible, use metal connector shells that connect around the full circumference of the cable screen: they are far superior to those that earth the screen by a simple “pig-tail”.
- The keyboard and mouse will play an important part in the compatibility of the processor card since they are ports into the board. Similarly, they will affect the compatibility of the complete system. Fully compatible peripherals must be used otherwise the complete system could be degraded. They may radiate or behave as if keys/buttons are pressed when subject to interference. Under these circumstances it may be beneficial to add a ferrite clamp on the leads as close as possible to the connector. A suitable type is the Chomerics type H8FE-1004-AS.
- USB cables should be high quality screened types.
- Ensure that the screens of any external cables are bonded to a good RF earth at the remote end of the cable.

Failure to observe these recommendations may invalidate the EMC compliance.

## Quick Start

The following sections explain how to install the ZETA C710 Industrial PC (IPC).

First ensure that you are familiar with the contents of the section [“Precautions”](#). It contains important information to avoid damage to any of the internal components.

If the mouse and keyboard are to be removed for normal operation, shut down the computer and switch off the power before removing them.

Follow the connection details shown in the [Installation section](#) of this guide, and connect the required external cables into their matching sockets on front face of the ZETA C710 IPC.

There are two options for powering ZETA C710. One is via a 2.5/5.5mm Jack, the other is via a wired connector. Ensure you use the appropriate connection method for the unit to be installed.

The ZETA C710 IPC will usually be provided with an Operating System installed. For XP Professional Users, when the unit is first powered on, the unit will go through the Microsoft mini Setup process, where the customer is required to enter the details necessary to customise the operating system to their own requirements.

If a Microsoft embedded image is supplied, then the ZETA C710 will boot up without intervention.

To mount the unit using brackets provided by Blue Chip Technology, then, refer to the [Mounting section](#) in this document for further guidelines. If using a 3<sup>rd</sup> party mounting arrangement, follow the installation instructions recommended by the vendor.

## External Connections

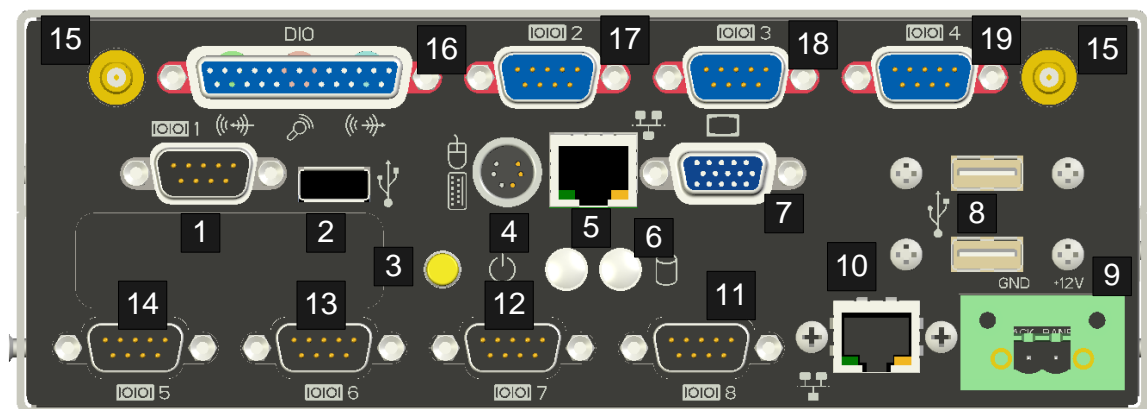

Figure 1 – Front Connectors



Figure 2: Rear Connector

Note: In Figure 1, not all optional connection types shown are available on the same unit

Connector	Description	Connector	Description
1	Serial Port 1	11	Serial 8 – Optional
2	USB x 1	12	Serial 7 – Optional
3	On / Off switch	13	Serial 6 – Optional
4	Keyboard/Mouse	14	Serial 5 – Optional
5	LAN 1	15	WiFi Aerial – Optional
6	Power and Activity LED's	16	GPIO/Audio – Optional
7	VGA	17	Serial 2
8	USB x 2	18	Serial 3
9	Power In (Wired) - Optional	19	Serial 4
10	LAN 2 - Optional	20	Power In (Jack)

## Chassis Cover Removal

The Zeta C710 has been designed with removable top and bottom covers to allow quick and easy access to whichever section is required.

Any brackets that have been fitted need to be removed first.

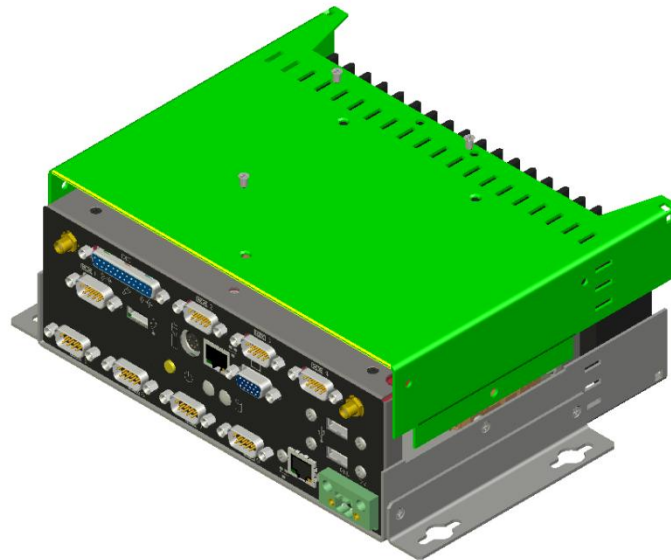

Figure 3: Top Cover



Figure 4: Bottom Cover

## Internal Connections

### CMOS Battery

In the event of CMOS corruption it may be necessary to remove the CMOS Battery for a short period in order to allow the default CMOS settings to be recovered.

The Battery is accessed by removal of the top cover and can be removed by pushing the top retaining clip backwards and lifting the battery from its socket.

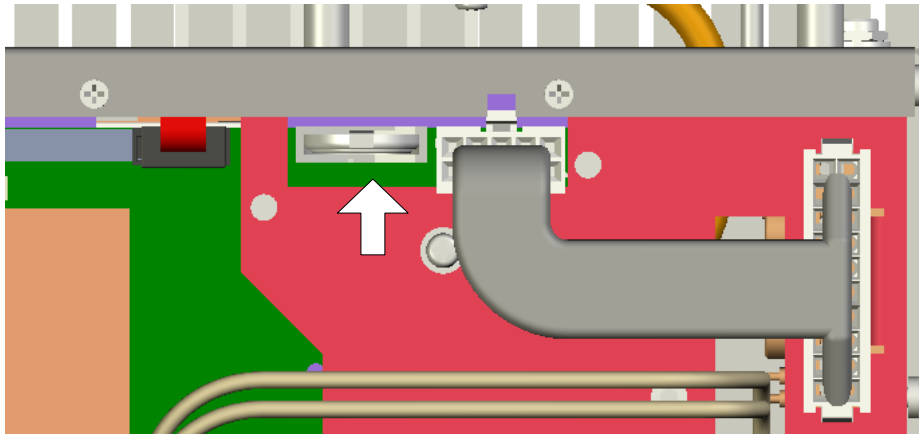

Figure 5: CMOS Battery

### Changing System Memory

The system Memory requires an amount of disassembly before access can be achieved. This requires removing top and bottom cover, front cover and then the thermal plate. If a HDD is fitted then this also must be removed.

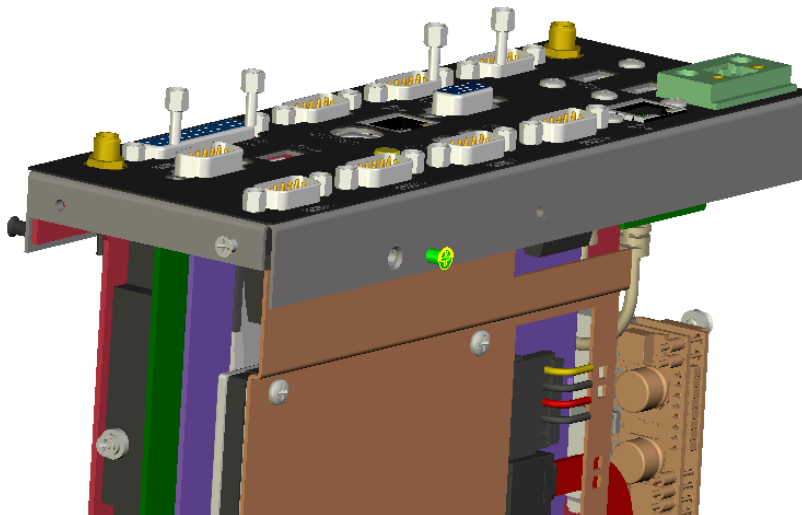

Figure 6: Removal of Front cover

The front plate needs to be removed to allow access to screws retaining the Thermal Plate

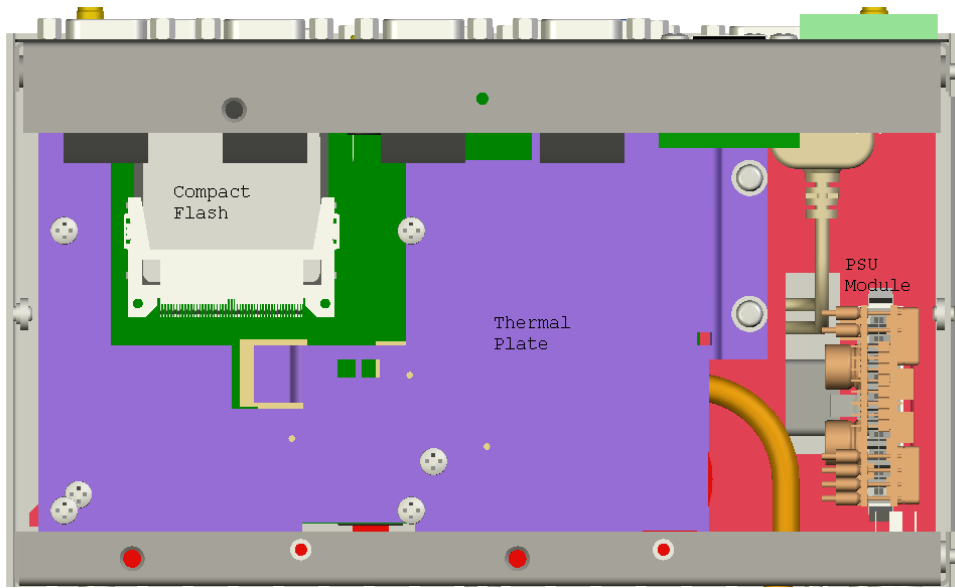

Figure 6A: Bottom view showing Thermal Plate

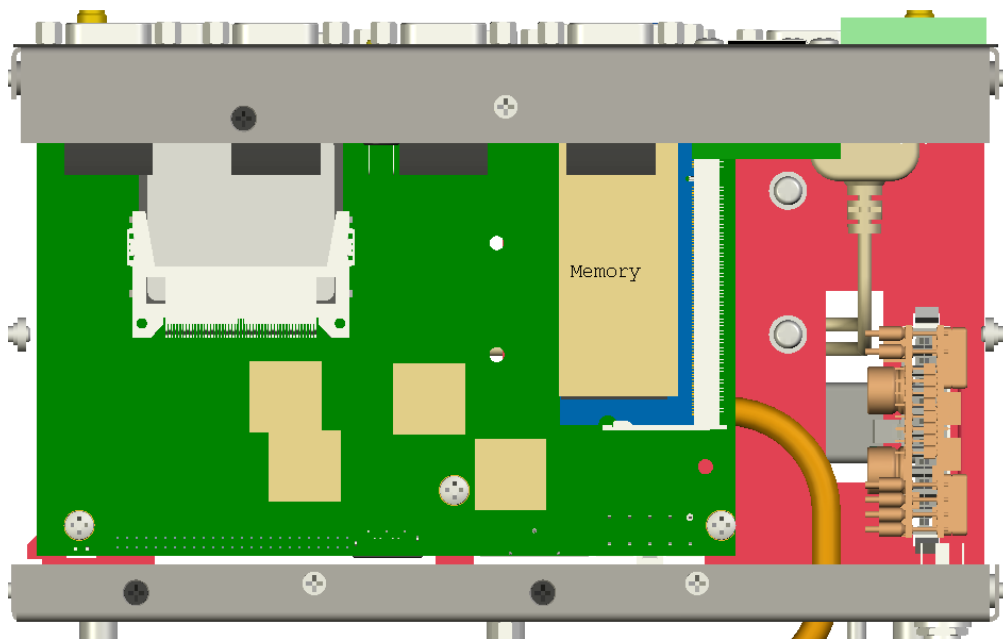

Figure 7: Bottom view showing Memory socket

## Changing Compact Flash

If fitted, the Compact Flash module can be accessed by removing the bottom cover, but without the need to remove the thermal plate.

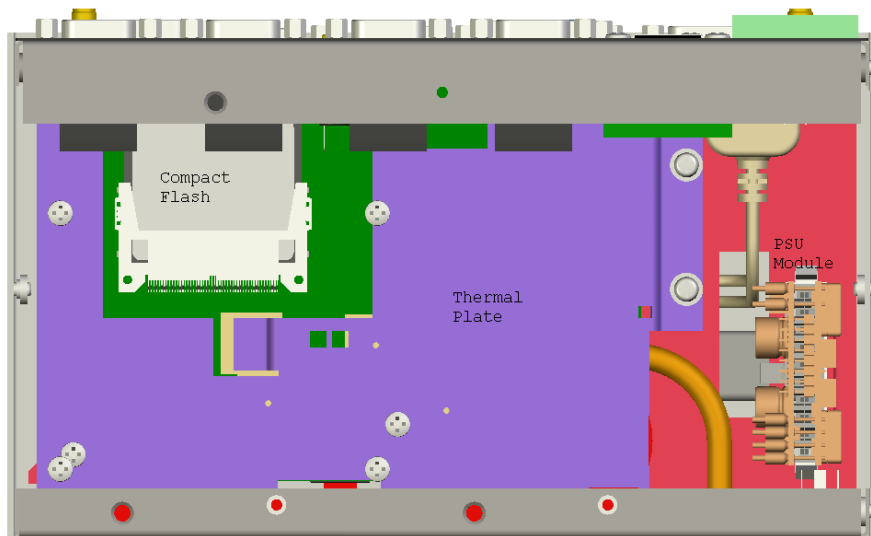

Figure 8: Compact Flash Socket

## Changing HDD

If fitted, the HDD can be accessed by removing the bottom cover.

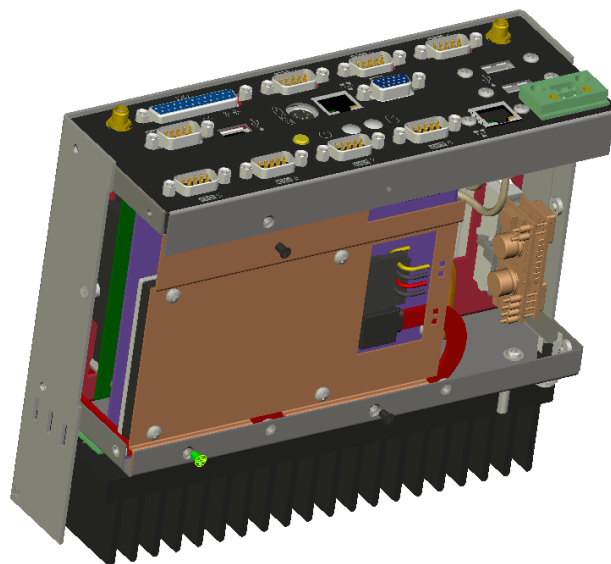

Figure 9: HDD

The HDD is attached to a metal plate as shown above. To remove the HDD, first remove the 3 screws holding the metal plate and disconnect the power and signal cables.

## Changing miniPCI Module

The miniPCI connector can be accessed by removal of the top cover, and then the thermal plate.

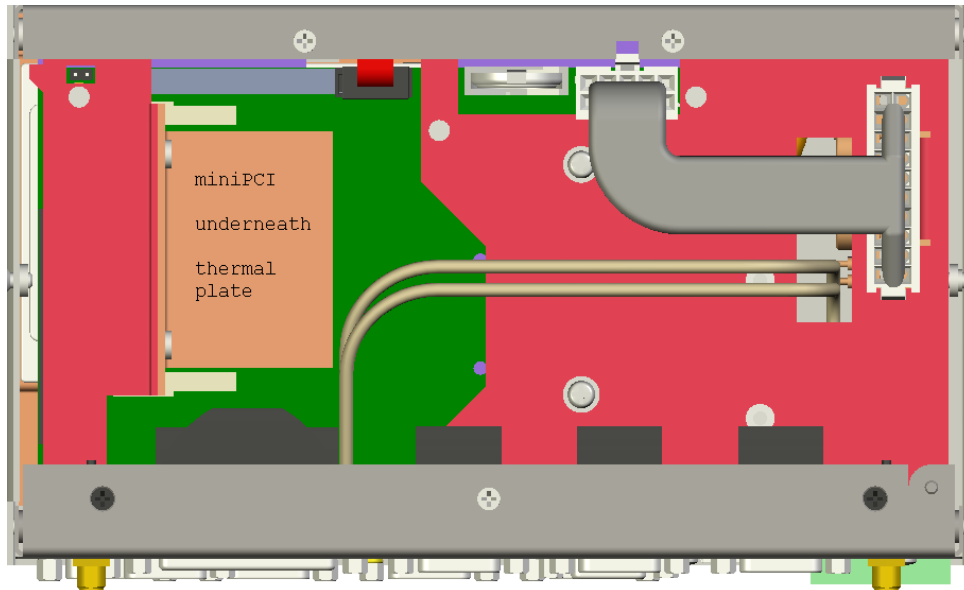

Figure 10: miniPCI Socket

The miniPCI socket can be configured with one of the following options ([refer to Figure 1 for external connection details](#))

1. 10/100 Ethernet Module (connector 10)
2. WiFi module (connector 15)
3. Serial Com's module (connectors 11, 12, 13 and 14)

## Optional Audio/GPIO Connection

The Zeta C710 can provide either 16 GPIO lines or AC'97 compatible audio.



Figure 11: Optional GPIO/Audio

The GPIO or Audio connector is held in place by two hex screws

## Internal PSU Options

The Zeta C701 can be powered directly by 12V (via a jack) or by an optional wide ranging 12V input (connected to wired connector).

Both power inputs connect to the SBC as shown in Figure 12 below.

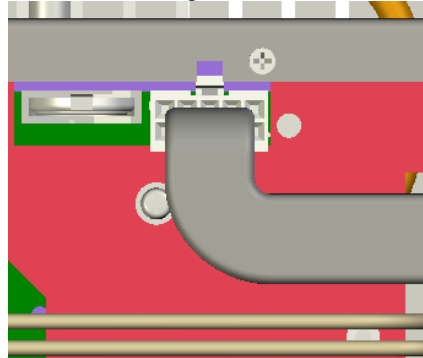

Figure 12: SBC Power Connector

This power connector either connects direct to the Power Input Jack, or in the case of the wide ranging power option, connects to a Power Module as shown below in Figures 13 and 14

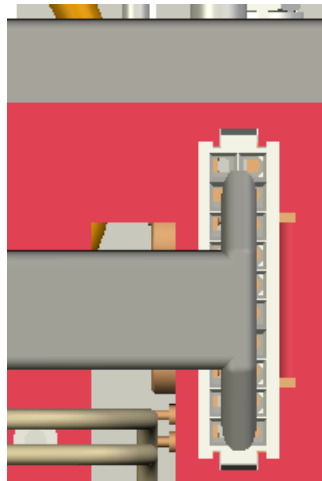

Figure 13: Power Module (1)

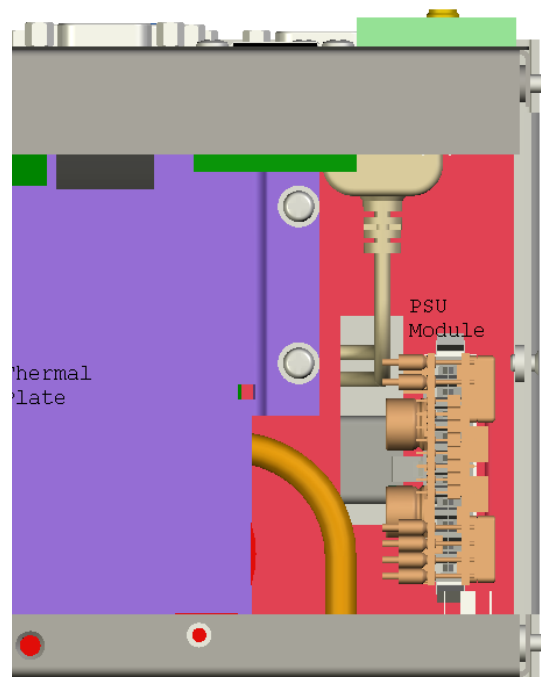

Figure 14: Power Module (2)

## Mounting Arrangements

The Zeta C710 can be supplied with two mounting options. The first is a DIN Rail mount connector which connects to the base of the unit and allows for the connection to a standard DIN Rail.

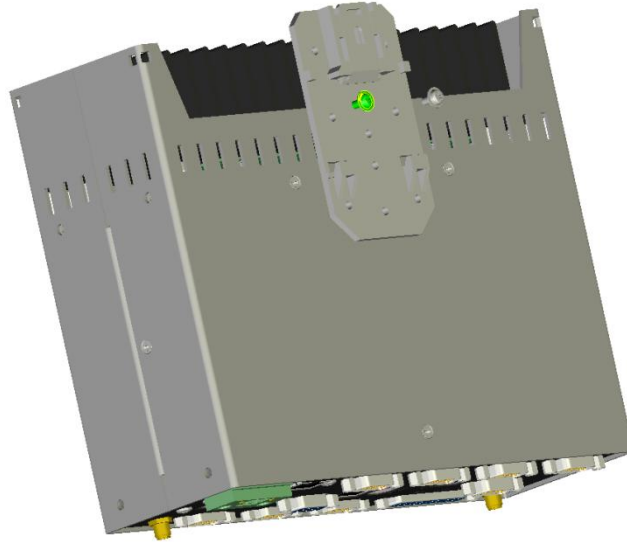

Figure 15: DIN Rail Connector

The connector is held in place by two screws as shown in Figure 15.

The second mounting option is via a pair of brackets attached to the side of the unit which allow attachment to a flat surface such as a wall or other brackets.



Figure 16: Side Brackets

Each side bracket is held in place by two screws as shown in Figure 16.

Outline Drawings

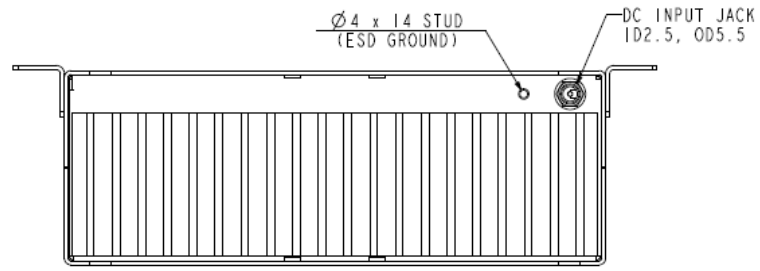

Figure 17: DC Jack

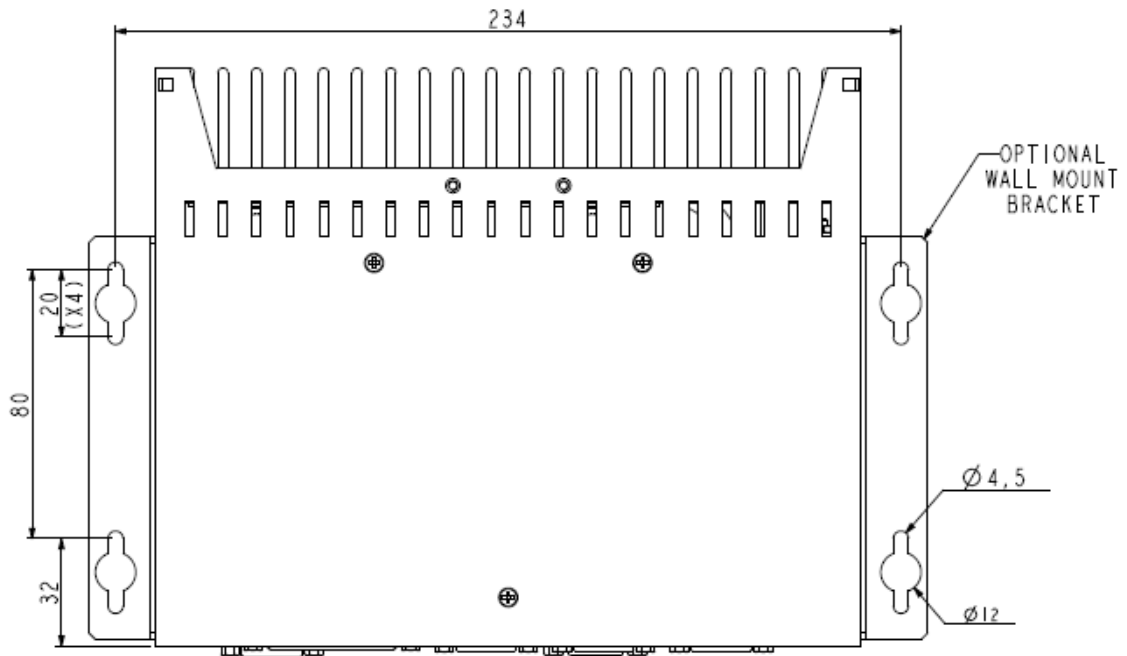

Figure 18: Footprint including brackets

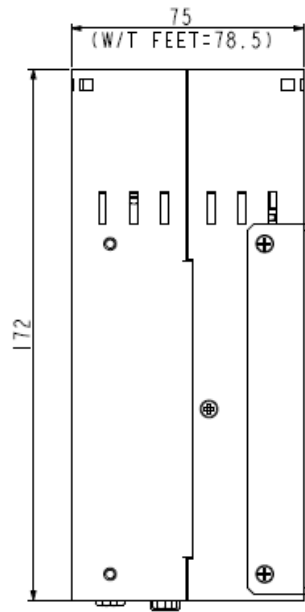

Figure 19: Side Dimensions

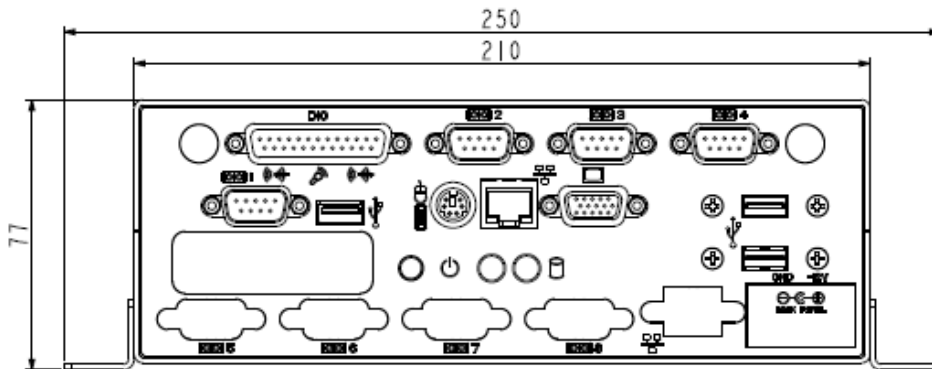
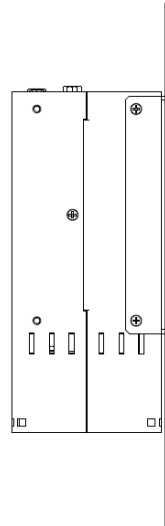
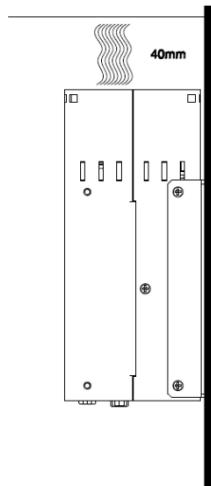
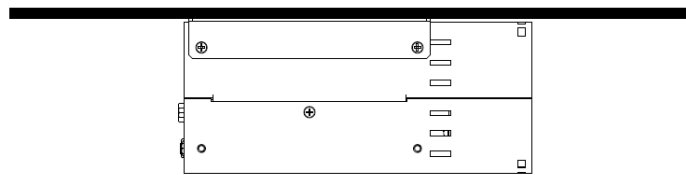
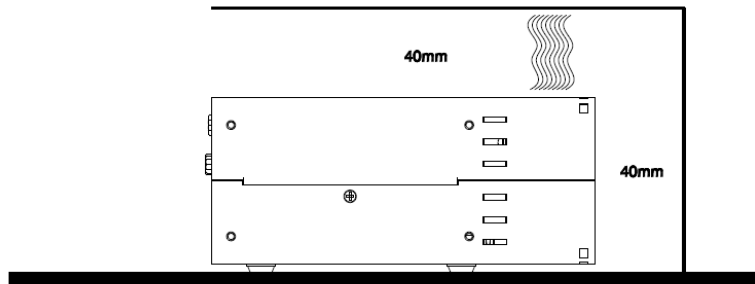

Figure 20: Front Dimensions

### Permitted Orientations



## System Software

### Operating System Install

The Zeta C710 Industrial PC should come with an Operating system Pre-installed.

#### *XP Professional*

For Windows XP Professional, when the unit is powered on, the Operating System should go into the Microsoft mini Setup routine, where the User details can be entered.

Once Software Applications have been installed, it is recommended that a backup of the storage media is performed. In the event of Operating System corruption, this will make recovery much easier.

If no backup has been performed, then the Operating System will have to be re installed from the Operating System CD supplied with the PC. Additional Drivers for the Zeta C710 can be found on the Blue Chip Technology Support DVD

The drivers can be found in the following location on the DVD

\\Drivers\AlphaZeta\C7

### GPIO Software Programming

Access to the GPIO is via address 123h. Performing a Byte Read on this address returns the status of the Input pins, while performing a Byte Write, adjusts the status of the Output pins

Pin	Signal	123h Bit	Pin	Signal
1	Out-0	0	14	In-0
2	Out-1	1	15	In-1
3	Out-2	2	16	In-2
4	Out-3	3	17	In-3
5	Out-4	4	18	In-4
6	Out-5	5	19	In-5
7	Out-6	6	20	In-6
8	Out-7	7	21	In-7
9	Ground	-	22	Ground
10	No Connect	-	23	No Connect
11	No Connect	-	24	No Connect
12	No Connect	-	25	No Connect
13	No Connect	-		

For example, to set output pins 0, 2, 4 and 6 to high, and 1, 3, 5 and 7 to low write 55h to address 123h  
If reading AAh from address 123h, then Input lines 1, 3, 5, and 7 are high and lines 0, 2, 4 and 6 are low

## Watchdog Timer

The Zeta C710 comes equipped with a built in Watchdog function which can reset the system in the event of the system hanging or locking up.

This function can be activated as shown in the following example

Output	Step	Comment
	Start – Unlock Watchdog	
2E 87	Un-lock super I/O	
2E 87	Un-lock super I/O	Output repeated
	Select Logical Device 0	
2E 07		
2F 00		
	Set WDT Function Enable	
2E 2B		
2F 00		
2E, 07		
	Select Logical Device 0	
2F 08		
	Activate Watchdog	
2E 30		
2F 01		
	Set time = seconds	
2E F3		
2F 00		
	Set Base Timer	
2E F4		
2F M		Where m = 01 to FF (1-255 seconds)
	Disable Watchdog	
2E 30		
2F 00	Can disable at any time	Can disable at any time

To refresh the watchdog, rewrite the Base Timer value before it counts down to 0. Else the system will reset

## System BIOS

The Zeta C710 Industrial PC uses the Phoenix-Award BIOS, which has a built-in Setup program that allows users to modify the basic system configuration. This type of information is stored in a battery-backed RAM (CMOS RAM) that retains the Setup information each time the power is turned off.

To enter the BIOS setup pages, press the <DEL> key just after powering on the unit

If you want to temporarily change the BOOT order, for example to boot from a USB device, then during POST or when the Splash screen is being displayed, press the <ESC> key to enter the BOOT selection Menu.

## BIOS Menus

The following pages show the Menu pages found when entering the BIOS. These pages can be used as a reference guide and descriptions of the main user configurable options are provided for information.

The following pages do not go into great depth, so if you require more in-depth data on particular BIOS settings please contact Blue Chip Technology Technical Support staff via the web interface at

<http://support.bluechiptechnology.co.uk/>

***Caution: Changing settings to the wrong values can result in unreliable or non working unit. If this occurs, then resetting the CMOS may be required***

If changing settings, then it is recommended that these are recorded in a safe place for later reference

## *Navigation*

Navigation through the various pages is fairly straightforward and hints are given at the bottom of each page.

In general, when on a page, use the Up (↑), Down (↓), Left (←) and right (→) arrows to move around the page, use the Page Up <PgUp> or plus <+> key to increase the numeric value, the Page Down <PgDn> or minus <-> key to decrease the numeric value, and use the Enter <Enter> key to go to the sub menu for that particular option.

When in a Sub Menu, pressing the escape <ESC> key will return to the parent menu

## Main Menu

The Main Menu is the first screen that appears when you enter BIOS Setup. This screen provides access to the lower level menus

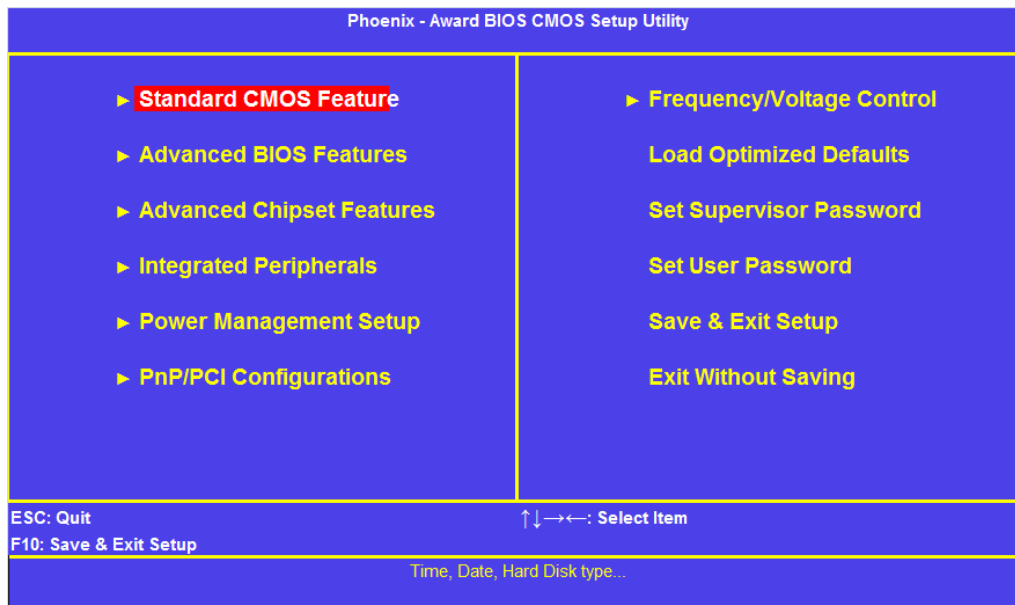

## Standard CMOS Feature



On the Standard CMOS Features page, the main user configurable setting is what to do if an error occurs during POST. The most common options are either ALL Errors or No Errors. If “No Errors” is chosen, then the unit will continue to boot, whereas if All Errors is chosen, then the unit will stop in POST requiring intervention before the unit boots.



## Integrated Peripherals

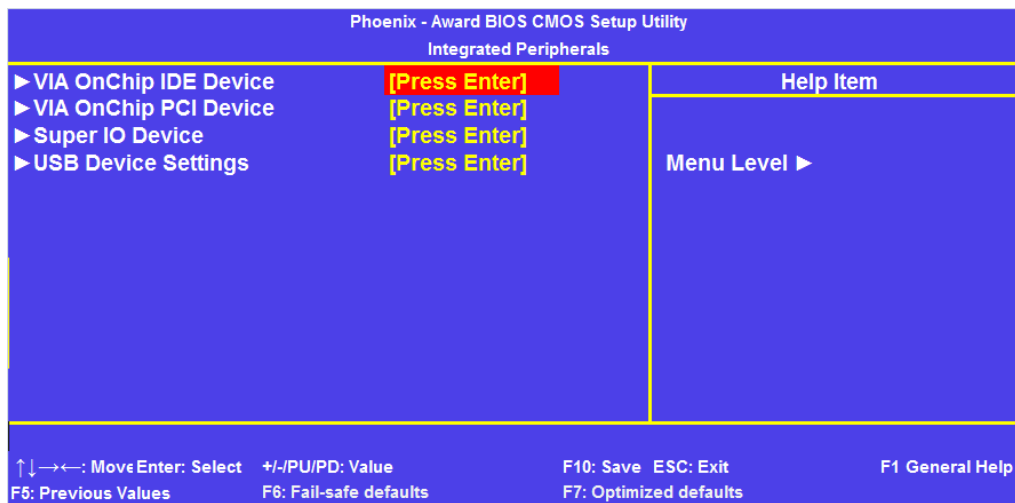

The Integrated Peripherals menu is the main menu for customer customisation

### VIA OnChip IDE Device

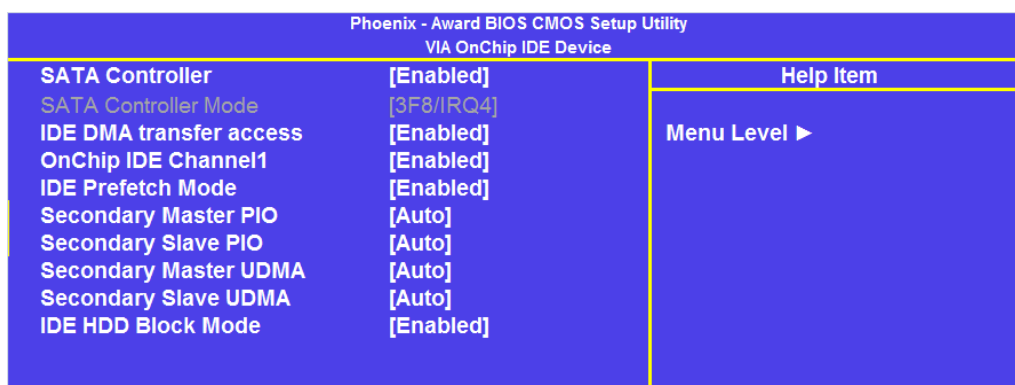

The IDE Device setup sub-menu allows the user to control how the IDE devices are setup.

### VIA OnChip PCI Device

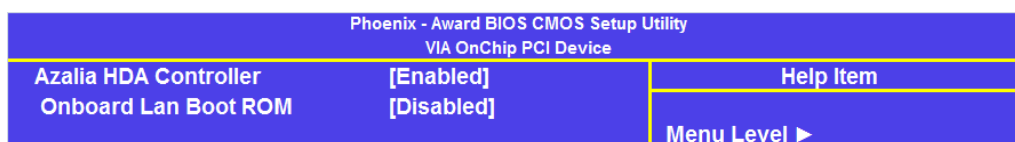

The PCI Device sub-menu determines whether the on-board Audio Device is Enabled or not, and if the LAN BOOT ROM is Enabled.

The Onboard Audio is an optional feature, so for units where the option is not fitted, then this feature should be set to Disabled.

*SuperIO device*

Phoenix - Award BIOS CMOS Setup Utility		
SuperIO Device Setup		
		Help Item
Onboard FDC Controller	[Enabled]	
Onboard Serial Port 1	[3F8/IRQ4]	
Onboard Serial Port 2	[2F8/IRQ3]	Menu Level ►
Onboard Serial Port 3	[3E8]	
Onboard Serial Port 4	[2E8]	
Serial Port 3 Use IRQ	[IRQ10]	
Serial Port 4 Use IRQ	[IRQ11]	
Onboard Parallel port	[378/IRQ7]	
Parallel port mode	[SPP]	
x EPP Mode Select	[EEP1.7]	
x ECP Mode Use DMA	[3]	

This sub-menu allows the user to configure the Serial Ports to their own specification. To free resources, both the Onboard FDC Controller and the Parallel Port should be disabled for normal use.

*USB Device Settings*

Phoenix - Award BIOS CMOS Setup Utility		
USB Device Setting		
		Help Item
USB 1.0 Controller	[Enabled]	
USB 2.0 Controller	[Enabled]	
USB Operation Mode	[High Speed]	
USB Keyboard Function	[Enabled]	
USB Mouse Function	[Enabled]	Menu Level ►
USB Storage Function	[Enabled]	

The USB Device page allows the User to Disable USB devices, if required for security reasons.

### Power Management Setup

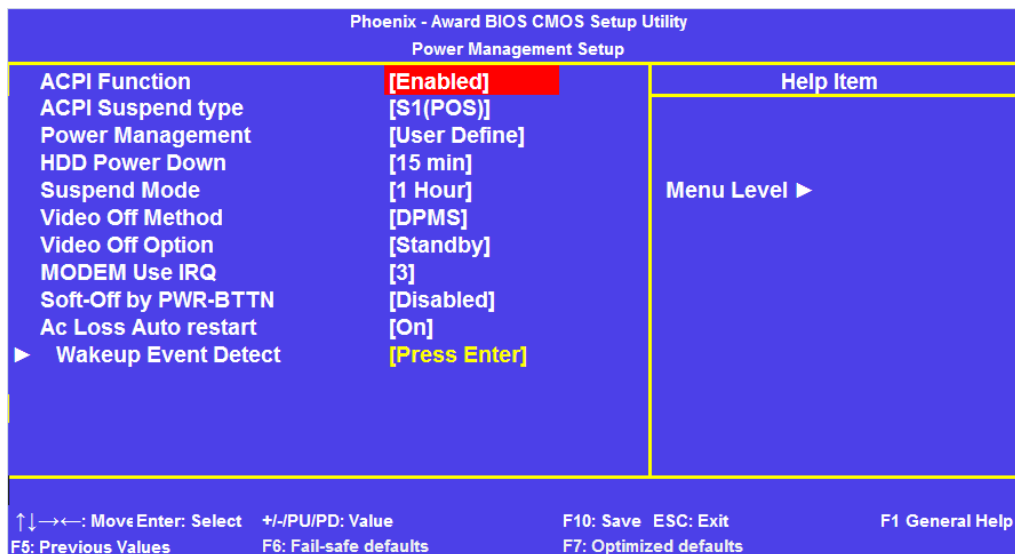

The Zeta C710 is designed for industrial applications and as such Power Saving features are usually disabled. If they are required then they can be setup from this menu.

One important setting is the option for “Ac Loss Auto Restart”. If the Zeta C710 is to be positioned in a difficult to access area, then setting the option to “ON” will allow the unit to boot up immediately when power is restored.

### PnP/PCI Configuration

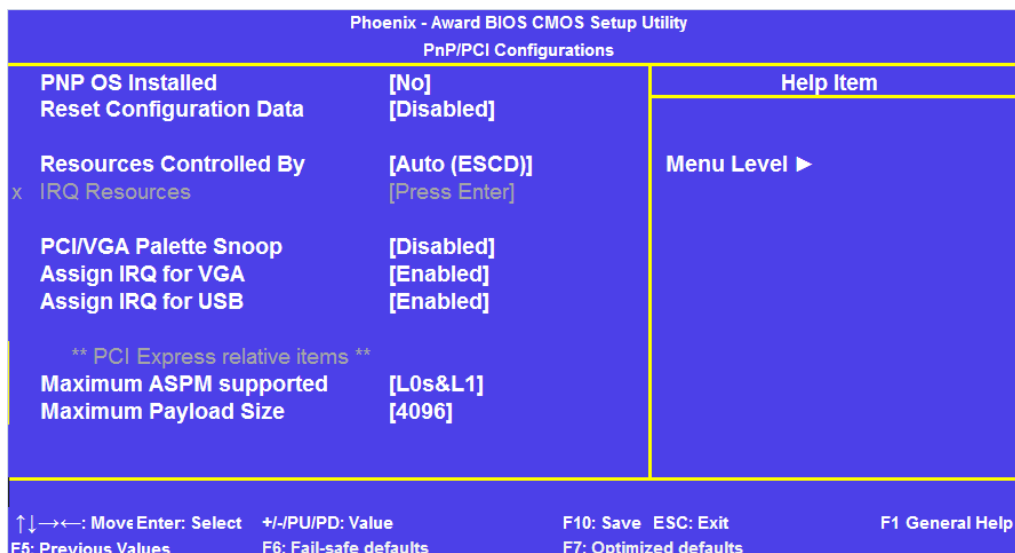

The Zeta C710 expansion options are limited to a single mini-PCI card, so the settings in this menu should not required to be changed

## Default Settings

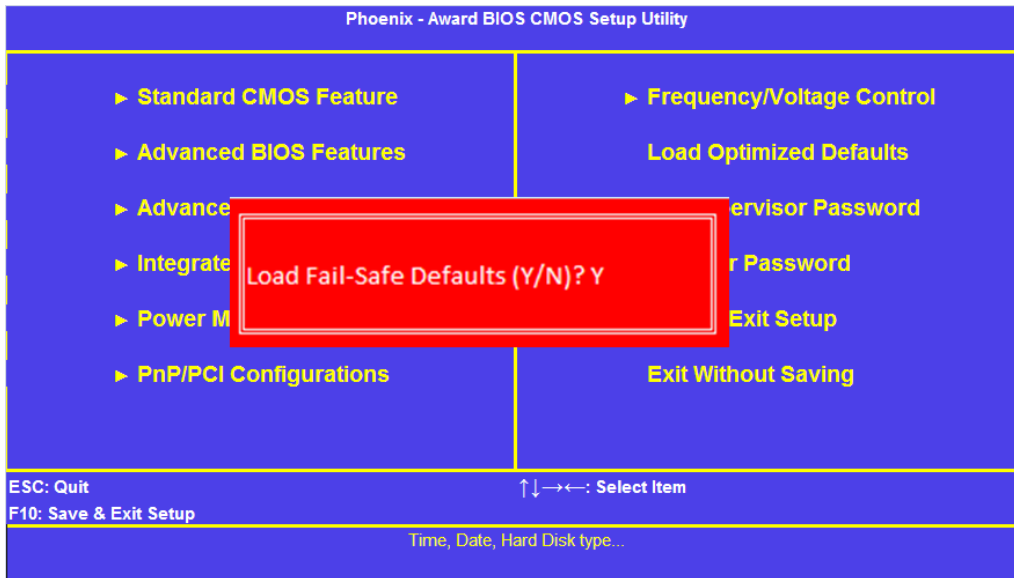

If the Zeta C710 becomes unstable after changing any of the BIOS settings, then it is recommended that the Default settings are restored, and any changes made one at a time to ensure a stable system

## Maintenance

The ZETA C710 Industrial PC should not require any regular maintenance. After a period of several years, it may be necessary to replace the battery on the processor board, if it cannot maintain the CMOS memory whilst the DC power is disconnected.

On a regular basis the inside of the Zeta C710 should be inspected and any dust build up cleared.

## Amendment History

Issue Level	Issue Date	Author	Amendment Details
1.0	18-08-2008	T Mck	First Release

### Contact Details

Blue Chip Technology Ltd.  
Chowley Oak  
Tattenhall  
Chester  
CH3 9EX  
U.K.  
Telephone: +44 (0)1829 772000  
Facsimile: +44 (0)1829 772001

[www.bluechiptechnology.co.uk](http://www.bluechiptechnology.co.uk)

*Plasma PC Sales*

[PlasmaPC@bluechiptechnology.co.uk](mailto:PlasmaPC@bluechiptechnology.co.uk)

*Single Board Computer Sales*

[singleboardcomputer@bluechiptechnology.co.uk](mailto:singleboardcomputer@bluechiptechnology.co.uk)

*Rack mount / Industrial PC Sales*

[rackmountpc@bluechiptechnology.co.uk](mailto:rackmountpc@bluechiptechnology.co.uk)

*Data and IO Sales*

[DataIO@bluechiptechnology.co.uk](mailto:DataIO@bluechiptechnology.co.uk)

*Technical Support*

[Support@bluechiptechnology.co.uk](mailto:Support@bluechiptechnology.co.uk)