



RE2
Single Board Computer
User Guide

Document Reference: RE2 User Guide
Document Issue: 1.5

Contents

Copyright	4
Limitations of Liability	4
Trademarks	4
Regulatory Statements	5
Safety Warning for North America	5
Manual Organisation	6
Introduction	7
Functional Overview	8
Specification	9
General Precautions	10
Electro-Static Discharges	10
On-Board Battery	10
Electromagnetic Compatibility	10
Mechanical Specifications	12
Connector Locations	13
Optional Communications Module	14
Connector Details	15
P1 – Ethernet Connector	15
P2 – Dual USB Connector (Edge of Board)	15
P3 – USB Device	16
P4/P15 – Power in Connector	16
P5 – Audio Connector	16
P6 – GPIO Connector	17
P7 – Utilities Connector	18
P9 – Dual USB Connector (Header)	18
P10 – RS232 Full Connector	19
P11 – RS232 & RS422/485 Connector	19
P8 – Video Connector	20
System Software	23
Operating Systems Supported	23
General Purpose I/O	23
RE2 Graphical User Interface(GUI)	24
System Firmware	26
Operating System Settings	27
Splash Screen	28
Display Configuration	29
Custom Settings	30
Firmware Update	31
Maintenance	32

Amendment History 33
Appendix I: Options and Assembly Guidelines 34
RE2 Antennae Guide 39

Copyright

All rights reserved. No part of this publication may be reproduced, stored in any retrieval system, or transmitted, in any form or by any means, electronic, mechanical, photocopied, recorded or otherwise, without the prior permission, in writing, from the publisher. For permission in the UK please contact Blue Chip Technology.

Information offered in this manual is believed to be correct at the time of printing. Blue Chip Technology accepts no responsibility for any inaccuracies. The information contained herein is subject to change without notice. There are no express or implied licences granted herein to any intellectual property rights of Blue Chip Technology Ltd.

Limitations of Liability

In no event shall Blue Chip Technology be held liable for any loss, expenses or damages of any kind whatsoever, whether direct, indirect, incidental or consequential, arising from the design or use of this product or the support materials supplied with this product. If this product proves to be defective, Blue Chip Technology is only obliged to replace or refund the purchase price at Blue Chip Technology's discretion according to their Terms and Conditions of Sale.

Trademarks

All trademarks and registered names acknowledged.

IBM, PC, AT and PS/2 are trademarks of International Business Machines Corporation (IBM).

AMD is a registered trademark of Advanced Micro Devices Inc.

MSDOS and WINDOWS are registered trademarks of the Microsoft Corporation.

Regulatory Statements

CE

This product has been designed and assessed to meet the essential protection requirements of the European EMC Directive (2004/108/EC), the Low Voltage Directive (2006/95/EC), and the R&TTE Directive (1999/5/EC) when installed and used in conjunction with the guidelines provided within this document.

[Note that compliance with the R&TTE directive is only required for those versions of the product equipped with radio frequency interfaces].

FCC

NOTE:

FCC compliance of product versions equipped with radio frequency interfaces may require specific approval for the finished products.

WARNING:

Changes or modifications not expressly approved by the manufacturer could void the user's authority to operate the equipment.

Safety Warning for North America

If the power lead (cord) is not supplied with the computer, select a power lead according to your local electrical regulations. In the USA use a 'UL listed' lead. In Canada use a CSA approved or 'cUL listed' lead.

Si le cordon secteur n'est pas livré avec l'ordinateur, utiliser un cordon secteur en accord avec votre code électrique nationale. En l'Etat Unis utiliser un cordon secteur 'UL listed'. En Canada utiliser un cordon secteur certifié CSA, ou 'cUL listed'.

Manual Organisation

This manual describes in detail the RE2 Product range.

We have tried to include as much information as possible but we have not duplicated information that is provided in the standard Technical References, unless it proved to be necessary to aid in the understanding of the product.

The manual is sectioned as follows:

- Introduction;
- Overviews, showing outline dimensions;
- Layout, showing where the various connectors are located, and their pin-out details;
- Firmware Setup
- Maintenance details

We strongly recommend that you study this manual carefully before attempting to interface with the RE2 or change the standard configurations. Whilst all the necessary information is available in this manual we would recommend that unless you are confident, you contact your supplier for guidance.

IT IS PARTICULARLY IMPORTANT THAT YOU READ THE SECTION 'PRECAUTIONS' BEFORE HANDLING ANY COMPONENTS INSIDE THE UNIT.

If you have any suggestions or find any errors concerning this manual and want to inform us of these, please contact our Technical Services department with the relevant details.

Introduction

The Blue Chip Technology RE2 (BCT-RE2) sets very high standards for integration of the processor, graphics, memory, and I/O technologies together with a unique connection system for selected LCDs.

The BCT-RE2 has two CPU options, 600MHz and 720MHz. The 600MHz CPU is also available as an extended temperature product. All RE2s are supplied with 256MB of SDRAM and 256MB of NAND Flash. Further, additional NAND Flash can be added through either the optional μ SD Card or optional MMC socket, if fitted.

The BCT-RE2 can operate from 7V DC input through to 36V DC input. Power requirements will vary depending on the LCD panel and other peripherals attached to the RE2.

For example with the 600MHz BCT-RE2 with the U.R.T. UMSH-8173MD-1T 5.7" Combined LCD and Touch Screen, the operational power requirements will vary between 5W for Windows CE6, without applications running, up to 10W with applications running and peripherals attached.

On its own, the RE2 operates at approximately 2W without power saving.

The BCT-RE2 has the capability to support a Lithium Battery via connector P14 to retain time when the unit is powered off.

Functional Overview

The following block diagram shows the key components of the RE2

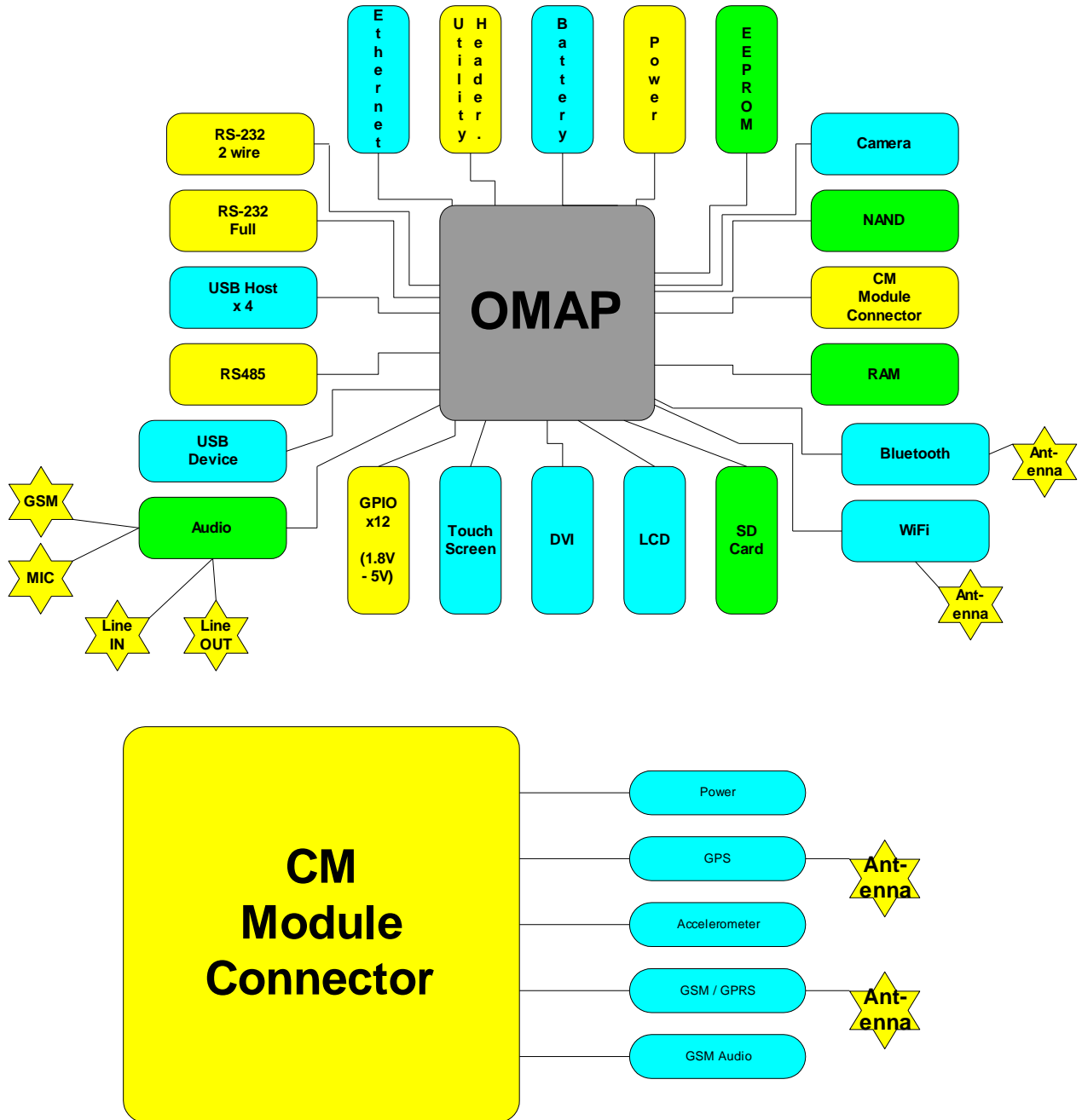

Specification

- Texas Instruments OMAP3530 Applications Processor
- 256 MB SDRAM soldered onboard
- 256 MB NAND Flash soldered onboard
- Optional μ SD Card NAND Flash Storage
- Video Controller - 18 bit RGB TTL
- 4 wire Touchscreen Controller
- 10/100 Ethernet including magnetics
- Quad USB 2.0 Hosts
- Single USB 2.0 Device
- Dual RS-232 (1 Full, 1 2-wire)
- Single RS-485
- Audio Codec Interface
- Battery backed Real-Time Clock
- 12 GPIO lines
- Utilities connector
- Wide Input Voltage – 7 to 36 volts (note: Input current is restricted to 1.6A maximum)
- Low power consumption – typically 2 watts (LCD not included)
- Bluetooth Class 2
- 802.11 b/g Wi-Fi
- Camera Interface
- Comms Interface (CM Module – GPS, GPRS)

General Precautions

Your Single Board Computer is susceptible to damage by electrostatic discharges. In order to avoid damage, you should work at an anti-static bench and observe normal anti-static precautions. Wear an anti-static wrist strap connected to an earth point *before* opening any packaging.

Where a wrist strap is not available, discharge any static charge you may have built-up by touching an earth point. Avoid any further movement that could build up another static charge. Touch an earth point from time to time to avoid further build-up, and remove the items from their anti-static bags only when required

Electro-Static Discharges

If you are going to open up the unit, it is important to realise that the devices on the cards within this unit can be damaged by static electricity. Bear in mind that the damage caused by static electricity may vary from total destruction to partial damage, which may not be immediately obvious. This could have an effect on the product's reliability and warranty. Before opening the chassis, ensure that you take necessary static precautions. Ideally you should work at an anti-static bench and wear an approved wrist strap or if that is not possible, touch a suitable ground to discharge any static build up before touching the electronics. This should be repeated if the handling continues for any length of time.

If it is necessary to remove a board or electronic assembly, place it into an anti-static bag. This will prevent any static electricity build up damaging the board. Metallised bags are preferred. Do not use black anti-static bags for any item containing a battery because these tend to be conductive and will discharge the battery.

On-Board Battery

The processor board can be fitted with a Lithium battery. Great care should be taken with this type of battery. If the battery is mistreated in any way there is a very real possibility of fire, explosion, and personal harm. Under NO circumstances should it be short-circuited, exposed to temperatures in excess of 100°C or burnt, immersed in water, recharged or disassembled.

Expired batteries remain hazardous and must be disposed of in a safe manner, according to local regulations.

Le panneau de processeur est équipé d'une batterie de lithium. Le grand soin devrait être pris avec ce type de batterie. Si la batterie est mistreated il y a de dans de toute façon un possibility très vrai du feu, d'explosion et de mal personnel. Dans au cunes circonstances il est sous peu circuité, exposé aux températures au dessus de 100 degrés de centigrade ou brûlé, immergé dans l'eau, rechargée ou dissassembled.

Les batteries expirées restent dazaedous et doivent être reejetées d'une façon sûre, selon des règlements locaux.

Electromagnetic Compatibility

This product has been assessed operating in representative, standard configurations. As with any PC product, however, final installation & configuration can vary significantly, and so the following guidelines are offered to help ensure that compatibility is maintained.

- All components added to a system should either carry appropriate equivalent levels of compliance, or be tested for compliance as part of the final system, and should be installed in accordance with supplier recommendations.
- The external enclosure should be securely fastened (with standard lids and covers in place) to ensure good metal-to-metal contact around the internal electronics

- Any metal back plate must be securely screwed to the chassis of the computer to ensure good metal-to-metal (i.e. earth) contact.
- Metal, screened, connector bodies should be securely connected to the enclosure.
- The external cabling to boards causes most EMC problems. It is recommended that any external cabling to the board be totally screened, and that the screen of the cable connects to the metal end bracket of the board or the enclosure and hence to earth. Round, screened cables with a braided wire screen are used in preference to those with a foil screen and drain wire. Wherever possible, use metal connector shells that connect around the full circumference of the cable screen: they are far superior to those that earth the screen by a simple “pig-tail”.
- The keyboard and mouse will play an important part in the compatibility of the processor card since they are ports into the board. Similarly, they will affect the compatibility of the complete system. Fully compatible peripherals must be used otherwise the complete system could be degraded. They may radiate or behave as if keys/buttons are pressed when subject to interference. Under these circumstances it may be beneficial to add a ferrite clamp on the leads as close as possible to the connector. A suitable type is the Chomerics type H8FE-1004-AS.
- USB cables should be high quality screened types.
- Ensure that the screens of any external cables are bonded to a good RF earth at the remote end of the cable.

Failure to observe these recommendations may invalidate the EMC compliance

Mechanical Specifications

Outline Dimensions

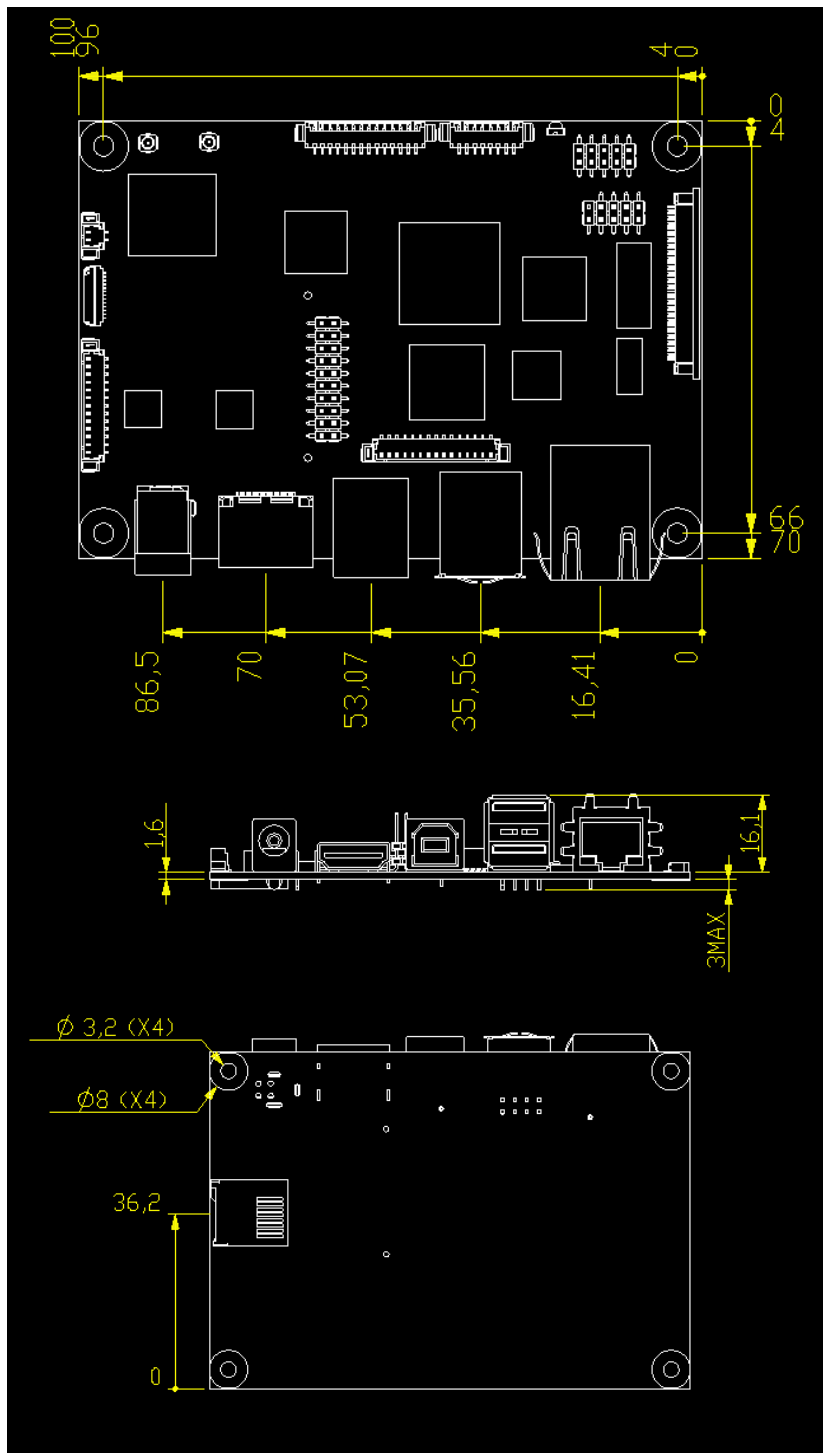

Connector Locations

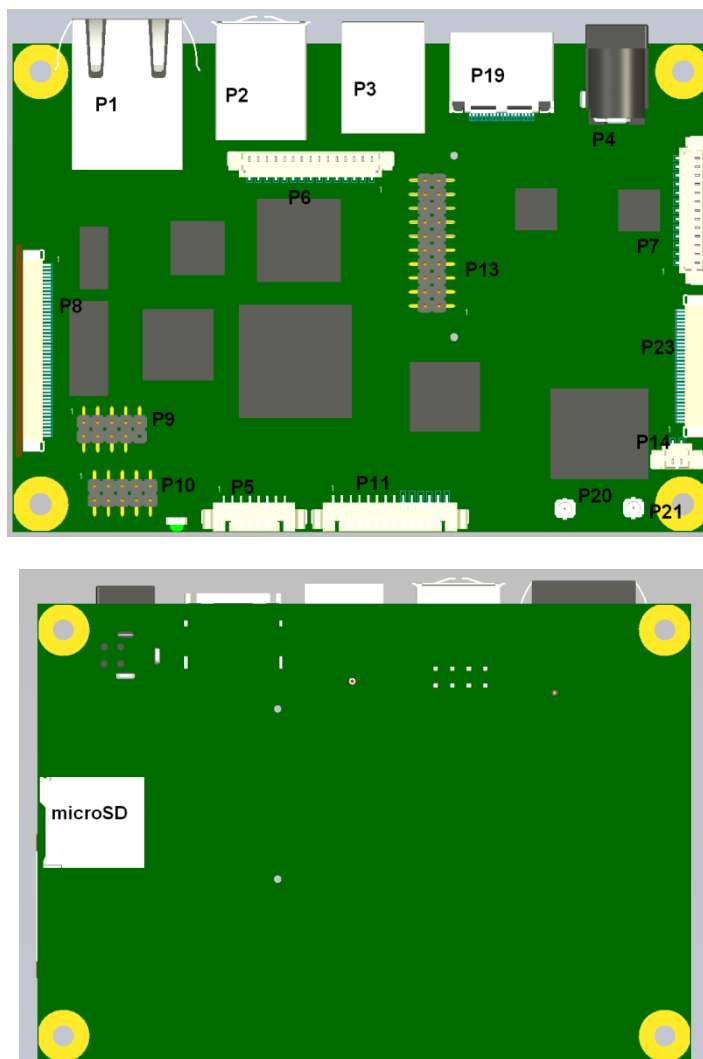

Connector	Description	Connector	Description
P1	RJ45 Ethernet	P2	USB-A x 2
P3	USB-B	P4 / P15	Power Input
P5	Audio	P6	GPIO
P7	Utilities	P8	LCD Video
P9	USB x 2	P10	RS232 (COM3)
P11	RS232 (COM2) and RS422/485(COM1)	P13	Connection to CM module
P14	Battery	P23	Camera
P20	Wifi Antenna	P21	BlueTooth Antenna

Note: Not all connectors may be fitted

COM2 is a 2 wire device and can be reserved for Debug use only via the Configuration utility

Optional Communications Module

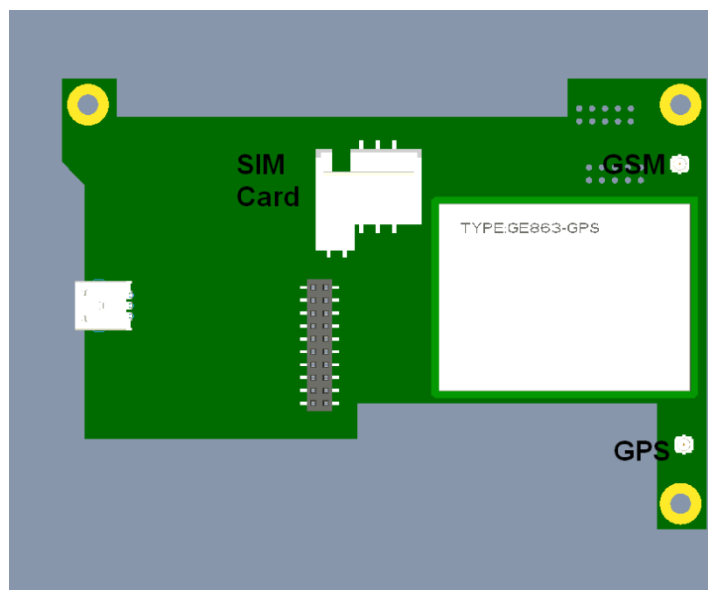

The connections to the Communications Module consist of connectors for GSM and GPS Antennae, and a socket for a SIM Card. Refer to the end of [Appendix 1 for more details on Antennae](#)

Connector Details**P1 – Ethernet Connector**

Pin	Signal	External Connections (RJ45)	Comments
1	TD+	1	Transit Data +ve
2	TD-	2	Transit Data -ve
3	CTT	-	Centre Tap Transmit
4	Ground	-	Electrical Ground
5	Ground	-	Electrical Ground
6	CTR	-	Centre Tap Receive
7	RD+	3	Receive Data +ve
8	RD-	6	Receive Data -ve
9	VCC3	-	Pull up to 3.3 volt VCC
10	LNK/#ACT	-	Link/Activity LED
11	SPD100#	-	Speed LED
12	VCC3	-	Pull up to 3.3 volt VCC
13	Ground	-	Electrical Ground
14	Ground	-	Electrical Ground

P2 – Dual USB Connector (Edge of Board)

Pin	Signal	Comments
1	VBUS	+5 volts – Filtered & current limited
2	D1-	USB 1 Data Negative
3	D1+	USB 1 Data Positive
4	Ground	Filtered Electrical ground
5	VBUS	+5 volts – Filtered & current limited
6	D2-	USB 2 Data Negative
7	D2+	USB 2 Data Positive
8	Ground	Filtered Electrical ground

P3 – USB Device

Pin	Signal	Comments
1	VBUS	+5 volts – Filtered & current limited
2	D-	USB 1 Data Negative
3	D+	USB 1 Data Positive
4	Ground	Filtered Electrical ground

P4/P15 – Power in Connector

The RE2 has the option to be powered from either a 2.5/5.5mm Power Jack (P4) or a 2 Pin Screw Terminal (P15)

P15	
Pin 1	Ground
Pin 2	Vcc

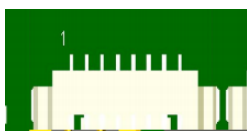

P5 – Audio Connector

Pin	Signal	Comments
1	Line Out Right	Audio Output Right Channel
2	Line Out Left	Audio Output Left Channel
3	Audio Ground	Audio Ground
4	Line In Left	Audio In Left Channel
5	Line In Right	Audio In Right Channel
6	Audio Ground	Audio Ground
7	Audio Ground	Audio Ground
8	Microphone IN	Mono Audio Input

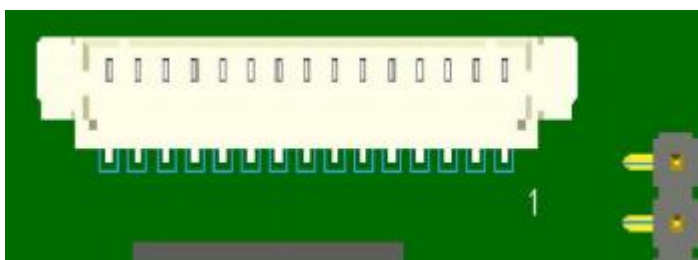

P6 – GPIO Connector

The GPIO interface is a flexible, logic-level port providing a mix of dynamically-configured hardware inputs and outputs. It is designed for use within a chassis with localised electronics. Interfacing to signals which may pick up noise transients will require buffering and/or conditioning circuits.

Pin	Signal	Comments
1	VCC_GPIO	Reference supply input
2	GPIO 1	Input/output
3	GPIO 2	Input/output
4	GPIO 3	Input/output
5	GPIO 4	Input/output
6	GPIO 5	Input/output
7	GPIO 6	Input/output
8	GPIO 7	Input/output
9	GPIO 8	Input/output
10	GPIO 9	Input/output
11	GPIO 10	Input/output
12	GPIO 11	Input/output
13	GPIO 12	Input/output
14	[Not used]	-
15	0V_GPIO	Tied to RE2 circuit ground

The GPIO outputs are designed for flexibility, and will interface to electronics operating with signal levels between 2.3V & 5.5V DC. The required I/O voltage must be provided to the RE2 at the VCC_GPIO pin (referenced to 0V_GPIO). The function and direction of the GPIO signals is configured by RE2 software (see the software manual for details of GPIO port mappings and configuration).

Basic electrical characteristics are as follows:-

Feature:	Pin(s):	Min:	Max:	Units:
V _{CC_GPIO} Supply Voltage	VCC_GPIO	2.3	5.5	V
V _{IH} Input High Voltage	GPIO 1 .. GPIO 12	V _{CC_GPIO} - 0.4	V _{CC_GPIO}	V
V _{IL} Input Low Voltage	GPIO 1 .. GPIO 12	0	0.15	V
V _{OH} Output High Voltage	GPIO 1 .. GPIO 12	V _{CC_GPIO} * 0.67	-	V
V _{OL} Output Low Voltage	GPIO 1 .. GPIO 12	-	0.4	V
ICC Supply Current	VCC_GPIO	-	12	μA

Quiescent output current in the high state appears equivalent to a 10K pull-up (short-duration current boosting is applied, however, during signal transitions to speed up rise/fall times). Optimum performance is achieved with short cable connections, and minimum capacitive loading on the signal lines.

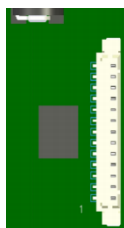

P7 – Utilities Connector

Power		Wake	
1	Power_Off#	8	Wake#
2	Ground	9	Ground
Reset		Battery	
3	Reset#	10	No connect
4	Ground	11	No connect
Serial Bus		Setup	
5	Serial Clock	12	Setup#
6	Serial Data	13	Ground
7	Ground		

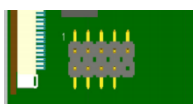

P9 – Dual USB Connector (Header)

Pin	Signal	Comments
1	VBUS	+5 volts – Filtered & current limited
2	VBUS	+5 volts – Filtered & current limited
3	D-	USB 3 Data Negative
4	D-	USB 4 Data Negative
5	D+	USB 3 Data Positive
6	D+	USB 4 Data Positive
7	Ground	Filtered Electrical ground
8	Ground	Filtered Electrical ground
9	Key	Removed
10	NC	Not connected

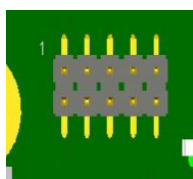

P10 – RS232 Full Connector

Pin	Signal	Comments
1	XDCD3#	COM 3 Data Carrier Detect
2	XR3	COM 3 RX
3	XTX3	COM 3 TX
4	XDTR3#	COM 3 Data Terminal Ready
5	0 volts	Electrical ground
6	XDSR3#	COM 3 Data Send Ready
7	XRTS3#	COM 3 Ready To Send
8	XCTS3#	COM 3 Clear to Send
9	XRI#	COM 3 Ring indicator
10	+5 volts	Fused voltage rail

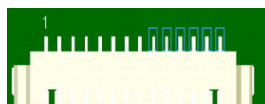

P11 – RS232 & RS422/485 Connector

Pin	Signal	Comments
1	0 volts	Electrical ground
2	RS232 RX	COM 2
3	RS232 TX	COM 2
4	+5 volts	Fused voltage rail
5	0 volts	Through 10K pull down
6	VCC	Through 10K pull up
7	Termination	120R + 100nF link to pin 10
8	CRX1N	
9	CRX1N	Same signal as pin 8
10	CRX1P	
11	CTX1N	
12	CTX1P	

With COM1 RS422/RS485 operation in a multi drop network, the Transmit Line is only enabled when the DTR line is enabled. Refer to the CE 6 User guide for more details



P8 – Video Connector

Pin	Signal	Comments
1	0 volts	Electrical ground
2	TS3	Touchscreen Data
3	TS2	Touchscreen Data
4	TS1	Touchscreen Data
5	TS0	Touchscreen Data
6	0 volts	Electrical ground
7	CPWM2	PWM Brightness Control 2
8	CPWM1	PWM Brightness Control 1
9	0 volts	Electrical ground
10	SDA/GP5	I2C Data or GPIO 5
11	SDCL/GP4	I2C Clock or GPIO 4
12	0 volts	Electrical ground
13	CB0	Blue 0
14	CB1	Blue 1
15	CB2	Blue 2
16	CB3	Blue 3
17	CB4	Blue 4
18	CB5	Blue 5
19	CB6	Blue 6
20	CB7	Blue 7
21	0 volts	Electrical ground
22	CG0	Green 0
23	CG1	Green 1
24	CG2	Green 2
25	CG3	Green 3
26	CG4	Green 4
27	CG5	Green 5
28	CG6	Green 6
29	CG7	Green 7
30	0 volts	Electrical ground
31	CR0	Red 0
32	CR1	Red 1
33	CR2	Red 2
34	CR3	Red 3
35	CR4	Red 4
36	CR5	Red 5
37	CR6	Red 6
38	CR7	Red 7
39	0 volts	Electrical ground
40	CFLM	First line Marker
41	CLP	Line Pulse
42	CDE	Display Enable
43	0 volts	Electrical ground
44	CCK	Pixel clock
45	ENPANL	Enable Panel
46	ENLITE	Enable Backlight
47	0 volts	Electrical ground
48	NC	No Connection
49	VIN	Raw Power input
50	VIN	Raw Power input

P23 Camera Port

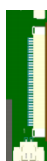

Pin	Signal	Comments
1	0 volts	Electrical ground
2	CAM_HS	
3	CAM_VS	
4	0 volts	Electrical ground
5	CAM_XCLKA	
6	CAM_PCLK	
7	0 volts	Electrical ground
8	CAM_FLD	
9	CAM_D0	
10	CAM_D1	
11	CAM_D2	
12	CAM_D3	
13	CAM_D4	
14	CAM_D5	
15	CAM_D6	
16	CAM_D7	
17	CAM_D8	
18	CAM_D9	
19	CAM_D10	
20	CAM_D11	
21	0 volts	Electrical ground
22	CAMXCLKB	
23	0 volts	Electrical ground
24	CAM_WEN	
25	CAM_STROBE	
26	VIO_1V8	
27	CAM_GLOBAL_RESET	
28	0 volts	Electrical ground
29	VCC3_3	
30	CAM_IRQ	
31	I2C3_SCL	
32	I2C3_SDA	
33	0 volts	Electrical ground

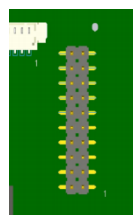

P13 – RE2 to CM1 Interface Connector

Pin	Signal	Signal Description
1	GND	Electrical ground
2	GND	Electrical ground
3	I2C3_SDA_3V	I ² C Data bus for Accelerometer and GPIO control
4	Not Connected	
5	I2C3_SCL_3V	I ² C Clock bus for Accelerometer and GPIO control
6	MCSPi2_CS0	SPI Interface to DUART on CM1
7	5VSS	Power Enable Input (to CM1)
8	MCSPi2_SOMI	SPI Interface to DUART on CM1 (output from CM1)
9	GSM_A_IN	GSM Audio Input to CM1
10	MCSPi2_SOMO	SPI Interface to DUART on CM1 (input to CM1)
11	GSM_A_IN#	GSM Audio Input to CM1 (GND return)
12	MCSPi2_CLK	SPI Interface to DUART on CM1
13	GSM_A_OUT#	GSM Audio Output from CM1
14	Not Connected	
15	GSM_A_OUT	GSM Audio Output from CM1 (GND Return)
16	Not Connected	
17	GND	
18	UART_IRQ#	GPRS & GPS interrupt (from DUART on CM1)
19	Vin	Power Input (to CM1)
20	Vin	Power Input (to CM1)

System Software

Operating Systems Supported

Windows CE 6.0

Linux

By Special Request:

QNX

VxWorks

Note: for CE 6 users care should be taken when using both Ethernet and Wireless Network ports at the same time. Windows CE does not support Multi homing. This means that if using both ports, only ONE gateway should be set. Refer to the following Microsoft article for more information

<http://msdn.microsoft.com/en-us/library/ee494457.aspx>

General Purpose I/O

There are 12 General Purpose I/O lines available. These can be accessed via either a WORD or BIT write/read

GPIO signals 7, 8 and 9 are shared with the I2S bus and GPIO signals 10 and 11 are shared with the IR bus.

If I2S and/or IR are enabled then these GPIO lines will not be available.

Due to the architecture, there are two considerations to be made when working with GPIO lines

1. GPIO lines 0 through 10 are accessed via one register, while GPIO line 11 is accessed via another register. This means that there may be some latency between GPIO 11 and the other GPIO lines
2. Accessing the GPIO lines individually (BIT Read/Write) will be faster than accessing them as a group (WORD Read/Write)

RE2 Graphical User Interface(GUI) for Windows CE

For Windows CE, the configuration settings on the RE2 are controlled via a graphical interface which is managed from a XP Professional or a Windows 7 32bit Admin PC.

The RE2 utility consists of the following files:



Also associated with the utility are the following driver files for the EVM Flash on the RE2

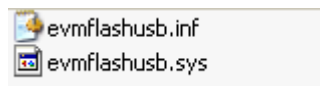

Step 1: Copy all files to a folder on your Admin PC

Step 2: Install the RE2 Utility using the Setup.exe file and follow the prompts

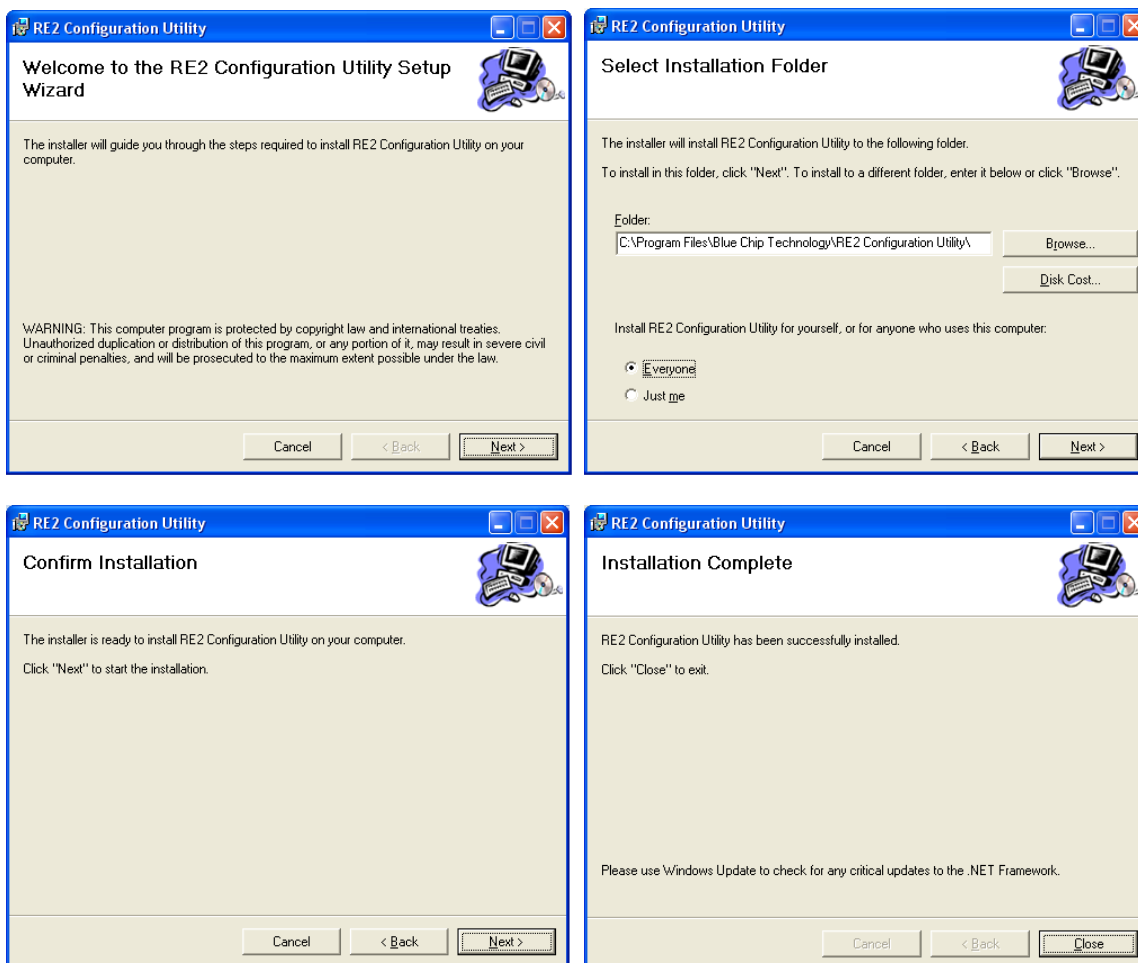



Once complete, the RE2 GUI Icon should appear on the desktop

Step 3: The first time a RE2 is connected to the Admin PC, Windows Device Manager will launch. This should see two devices; the first is the TI OMAP processor. When this appears direct the path for the driver to the folder containing the “evmflashusb” files. Next a USB device should be found and at the appropriate point, direct the path for the driver to the folder containing the “BCTUSBx.x” files. These files are installed as part of the RE2 GUI install. If default paths are chosen during the install then these files will be found at C:\Program Files\Blue Chip Technology\RE2 Configuration Utility\USB Driver

When installed, the RE2 device should appear in Device Manager when the RE2 is plugged in

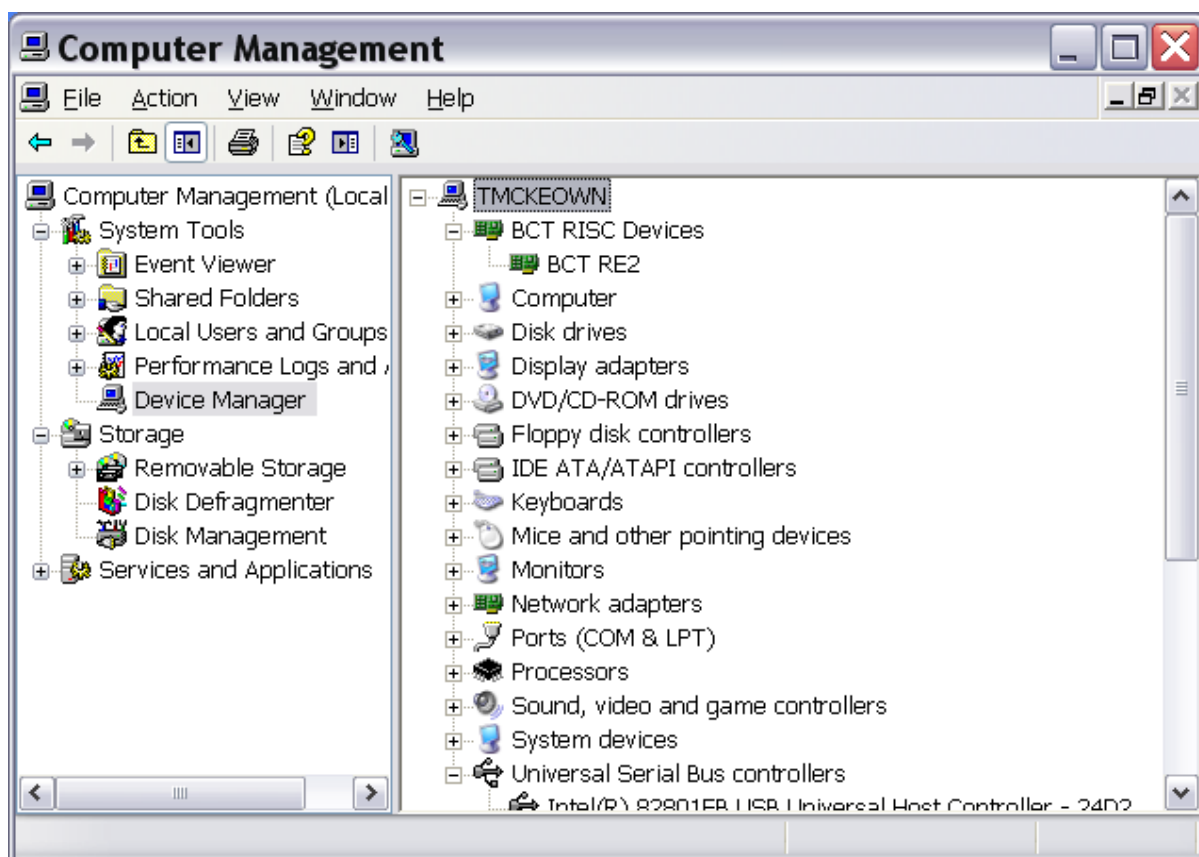

System Firmware for Windows CE

The system firmware is managed via the USB-B communications port as follows.

- 1- Install the RE2 GUI on your Admin PC as per the previous section
- 2- Connect the Admin PC to the RE2 via a USB-A/B cable
- 3- Short/Link the SETUP pins on the Utility Header and power on the RE2
- 4- The Power LED on the RE2 will remain unlit for approx 5 seconds, after this the LED should briefly flash. At this stage remove the short/link on the SETUP pins
- 5- Open the RE2 GUI on your Admin PC

Note: the RE2 GUI can be opened on the Admin PC before powering on the RE2. The GUI will appear as follows



As soon as a connection is made, the connection should appear on the GUI within a few seconds as below.



The current settings of the board are populated automatically, including Serial Number, MAC Address, Firmware Revision, current Boot device and Display output

Operating System Settings

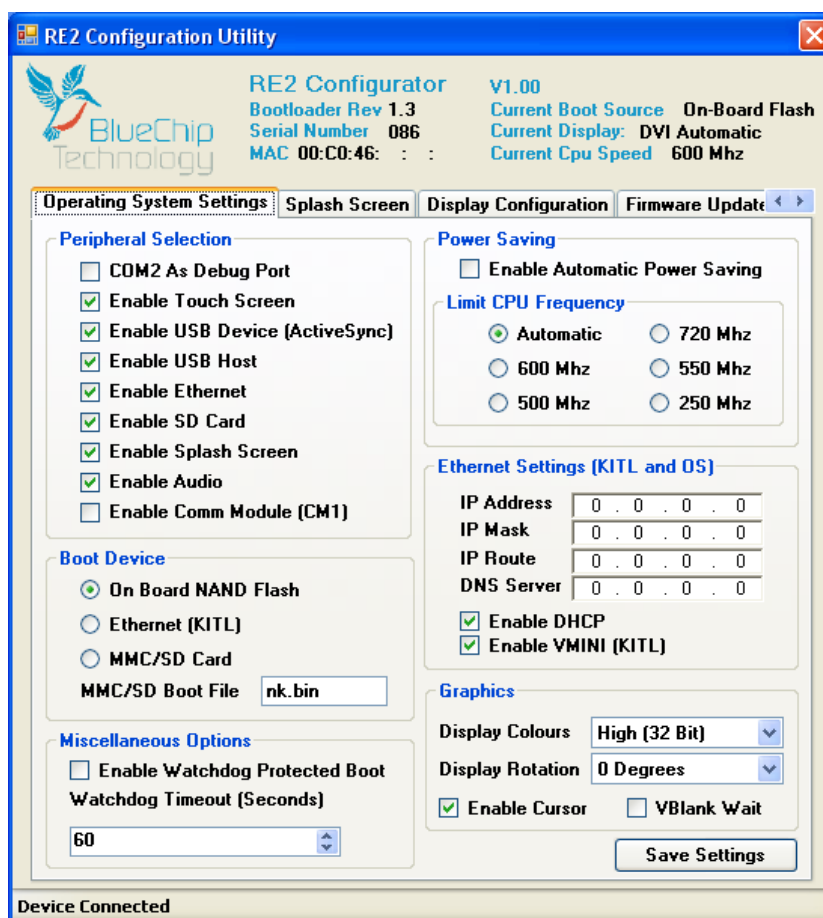

The first page provides most of the configuration settings for the RE2. These include

Peripheral Selection

These settings allow items not required by the application to be disabled, which will reduce the power requirement of the board, as well as preventing the device from being used incorrectly. For instance, disabling the USB HOST will prevent USB devices such as USB pens from being recognised by the OS. Another important selection is whether COM2 is made available as a RS232 port or is reserved for Debug use only

Boot Device

Changing the Boot Device could be useful for certain applications. For instance, multiple CE6 images could be developed containing different features and applications. With the Boot device set to MMC/SD, then just swapping the SD card could change the function instantly without the need to connect to another machine in order to change its configuration

Power Saving / Limit CPU Frequency

These settings allow the CPU to either be clocked back to save power permanently or to enable the CPU to go into power save mode when not in use. In Automatic Power Saving mode, the CPU clock frequency will drop in stages from its maximum down to the minimum 250 MHz value. These settings can be combined. For instance a 600 MHz unit could be limited to a max operating range of 500MHz. If Power Saving is also enabled, then the RE2 will drop move between 500MHz operation and 250MHz operation depending on activity.

Ethernet Settings

This allows the Ethernet to be set for DHCP or fixed addressing as well as allowing the KITL support for CE6 Debugging

Graphics

This section allows for Screen Rotation and Colour selection. Note that as rotation is carried out in software by the CPU, running a stressful graphical application while rotated could cause screen tearing and other anomalies to appear due to the CPU being over extended.

Miscellaneous Options

The RE2 supports a built in Watchdog which can be activated in this section. For instance, this can be used to confirm the OS has booted successfully, and after a successful boot, the OS turns off the Watchdog. If the OS boot is unsuccessful then the Watchdog will reset the RE2.

Splash Screen



The Utility allows a customer Splash screen to be installed on the RE2. Just load an image and press the update button and the image will be displayed on the RE2 screen. If the image is smaller than the display resolution – for example a 640x480 image with screen resolution of 800x600 – then the image will be centred on the screen. For the above example this would then show a black border around the image.

The Utility offers the option to resize the image automatically, which overcomes the need for multiple Splash screens of different sizes. However, if selected, then this will resize the image to the screen resolution at that time. If the RE2 is subsequently connected to a lower resolution display, then a “black” image will appear instead of the expected Splash screen.

Display Configuration



This settings page allows for the selection of a known display type as well as the option to customise the settings.

The default setting is “DVI Automatic”. When this is selected, the RE2 will read the EDID data from the display attached to the DVI port, and select the largest suitable resolution.

The options available are as follows:

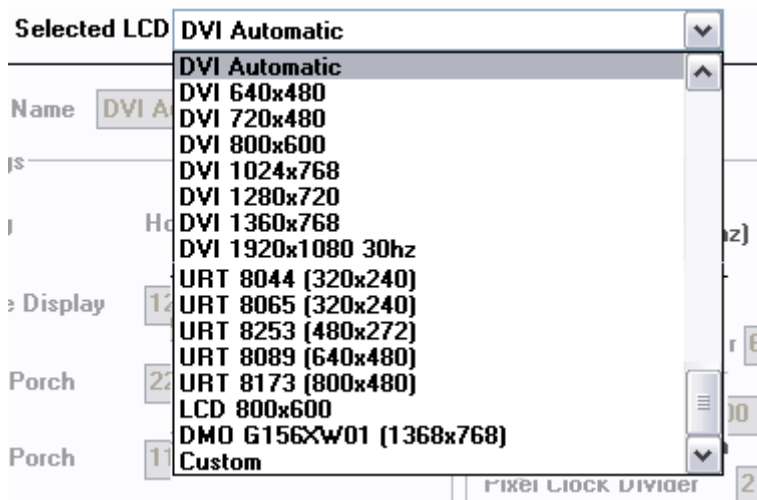

Custom Settings

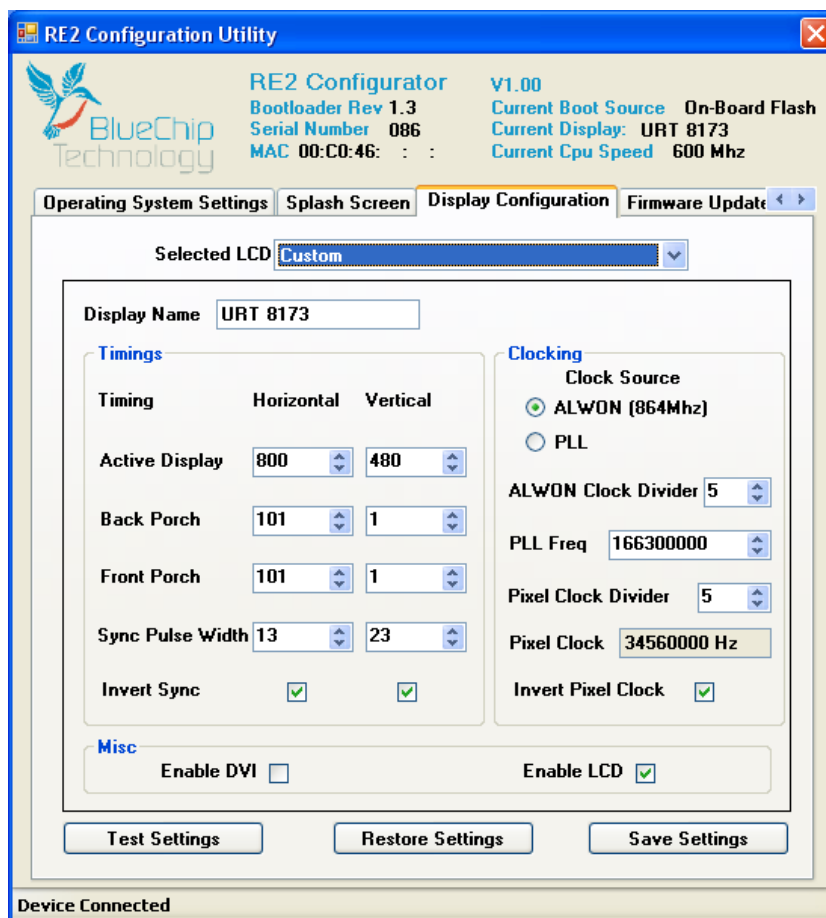

In order to use the Custom Setting option to use the RE2 on a different display type, you should first select a display type which is close to the one you wish to use.

In the above example, the URT 8173 panel has been selected, and then the Custom Setting selected. Once in the custom page, the settings which were previously greyed out are now available for editing.

If the timings for the custom panel are known, then enter them into the appropriate boxes. Press the “Test Settings” button, and the new settings will be outputted to the display. If the settings are not quite right, then change items one at a time, pressing the “Test Settings” button each time, until the desired output is achieved.

Once satisfied with the settings, press the “Save Settings” button

Firmware Update



The firmware update tab allows the updating of the RE2 with either an alternate Boot loader or System Image, avoiding the need for the RE2 to return to the factory for update.

Just select the appropriate file and once programming has completed, the RE2 can be rebooted.

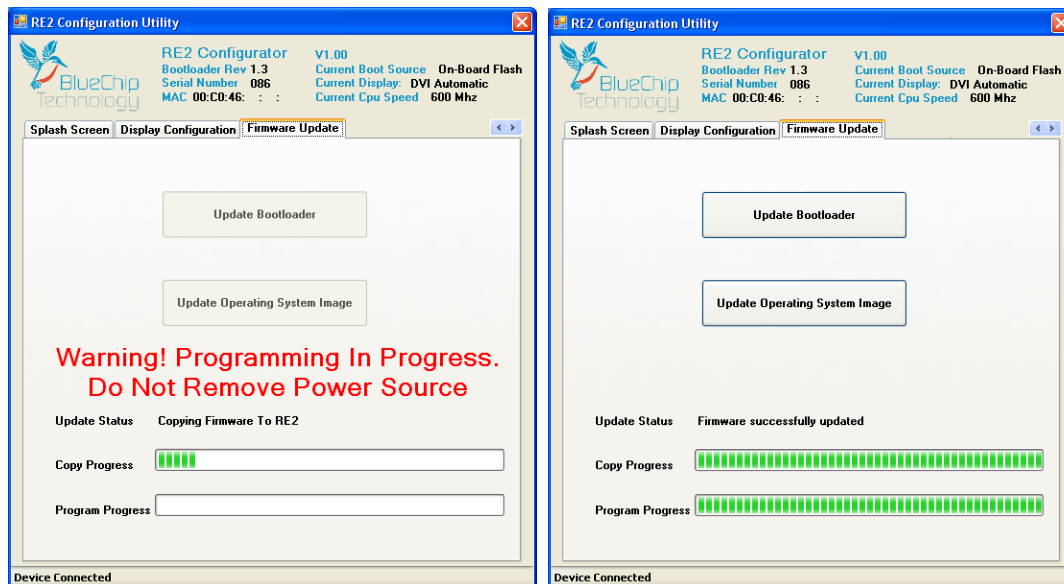

Note: The OS image is updated onto the Boot Device selected on the Operating Systems Page

Linux Firmware

Refer to the Linux for BCT RE2 User Guide for the equivalent methods of setting up the RE2 under Linux

Maintenance

The RE2Computer should not require any regular maintenance.

On a regular basis the inside of the unit which houses the RE2 should be cleaned out to prevent dust build up which could eventually cause elevated temperatures around key devices and prevent efficient and reliable operation.

Amendment History

Issue Level	Issue Date	Author	Amendment Details
1.0	19/11/10	TMCK	1 st Full Release
1.1	26/01/11	TMCK	Updated RE2 driver install instructions
1.2	04/02/11	TMCK	Corrected USB header details
1.3	13/07/11	TMCK	Added Wifi/BT P20 & P21 identifiers and detail
1.4	02/10	TMCK	Updated Linux reference
1.5	15-11-11	TMCK	Added pin 1 markings

Contact Details**Blue Chip Technology Ltd.****Chowley Oak****Tattenhall****Chester****CH3 9EX****U.K.****Telephone: +44 (0)1829 772000****Facsimile: +44 (0)1829 772001**www.bluechiptechnology.co.uk**Single Board Computer Sales**singleboardcomputer@bluechiptechnology.co.uk**Rack mount/ Industrial PC Sales**rackmountpc@bluechiptechnology.co.uk**Data and IO Sales**DataIO@bluechiptechnology.co.uk**Technical Support***Support@bluechiptechnology.co.uk**Returns****rma@bluechiptechnology.co.uk

* To use the Support email address requires the sender to be first registered on the Support Web site at

<http://support.bluechiptechnology.co.uk/>

**To request a Returns Authorisation number, use the RMA portal at

[Http://rma.bluechiptechnology.co.uk](http://rma.bluechiptechnology.co.uk)

Appendix I: Options and Assembly Guidelines

The following parts and accessories may have been supplied by BlueChip Technology, with their mating connections shown below or later in the document

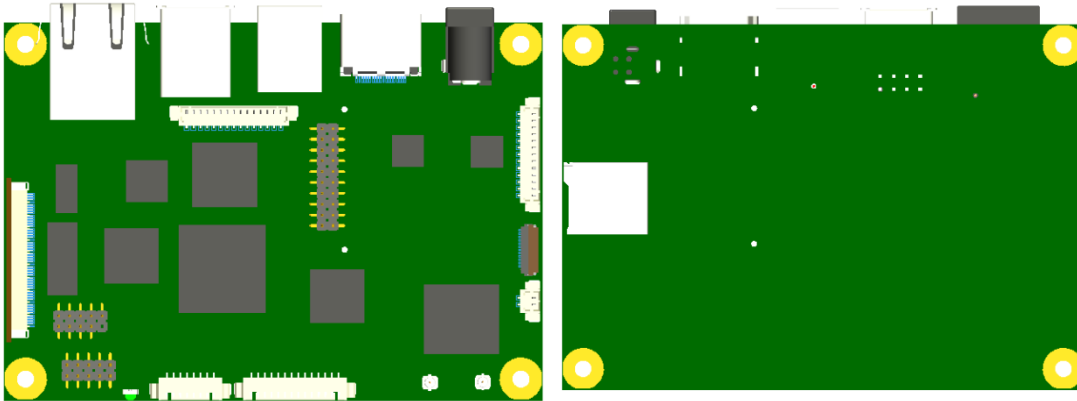

RE2 Connections Top and Bottom



LCD

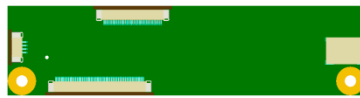

Personality Module

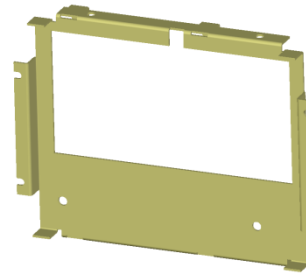

Metal Work

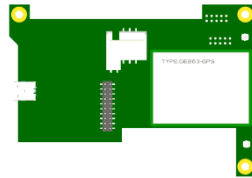

Communications Module

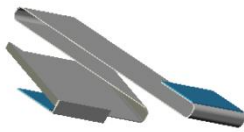

Flat Flexible Cable (FFC) (P8)

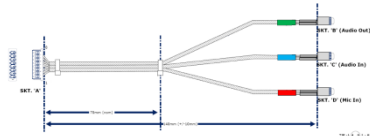

Audio Cable (P5)

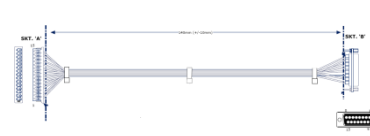

GPIO/I2S Cable (P6)

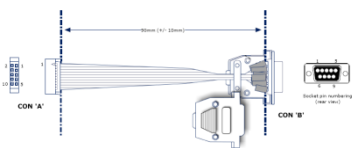

Serial (COM3) (P10)

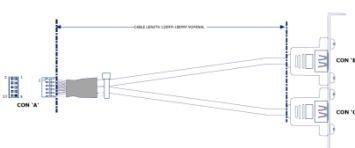

USB x 2 (P9)

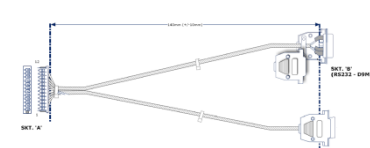

Serial (COM1+2) (P11)

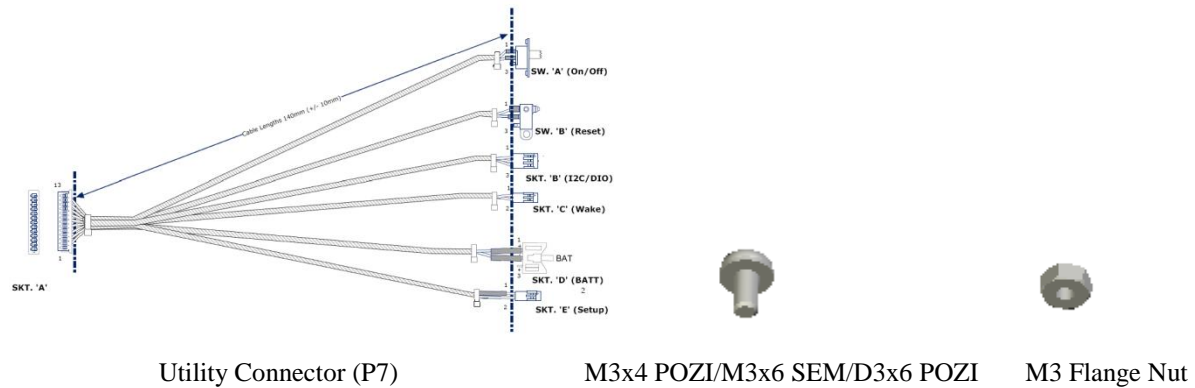

Utility Connector (P7)

M3x4 POZI/M3x6 SEM/D3x6 POZI

M3 Flange Nut

A Note About Electromagnetic Compatibility

The RE1/RE2 RISC engine can be supplied with a comprehensive selection of frames and cables ('evaluation kits') to enable easy access for OEM development and debug activities in a typical lab environment. As with any equipment operated in this manner, it is possible for radiated emissions to be higher than would be expected in a properly configured product, and the unit may also be more susceptible to external electromagnetic influences.

- The unit should not be operated in its 'evaluation kit' format in areas where radio-frequency interference with other equipment may affect either critical functionality or present a nuisance to others
- If interference is suspected, the unit should be turned off (to determine whether it is likely to be the source), and – if necessary – precautions taken to minimise the interference (eg: increased distance from the affected equipment, or improved screening/filtering – see later for additional guidance)

Ensuring the electromagnetic compatibility of a product produced using the RE1/RE2 unit is the responsibility of the manufacturer. To simplify this, Blue Chip Technology have worked to minimise emissions and improve susceptibility of these units at board level, and assessments have therefore been carried out in an 'open-frame' configuration to establish minimal guidelines for achieving compliance (to EN 55022 Class 'A' for RE1, and Class 'B' for RE2). Notes have been added throughout the following instructions to reflect these guidelines.

The RE1/RE2 products should also only be used with a suitably-compliant power supply. Blue Chip Technology can provide suitable units if required.

Assembly Instructions

The RE1 and RE2 RISC Engines are of the same footprint and connecting them to the LCD's and Blue Chip metalwork is the same. The first step is to fit the LCD to the Metalwork. The UMSH8253, UMSH8065, UMSH8173 and UMSH8376 LCD's require to be bonded to the metalwork using the VHB adhesive tape which is already applied to the metal work. **Before fitting, check that the Electronics all work together, as once fitted it will not be easy to separate the parts**

Peel back the VHB cover paper and carefully align the LCD with the metalwork before pressing together, ensuring that any cables on the LCD are placed through the relevant cut out in the metalwork. Before starting it may also be useful to roughly assemble the components so that you are familiar with how SBC's are aligned and how best to fold the FFC cable(s)

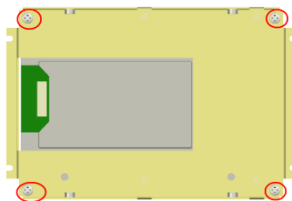
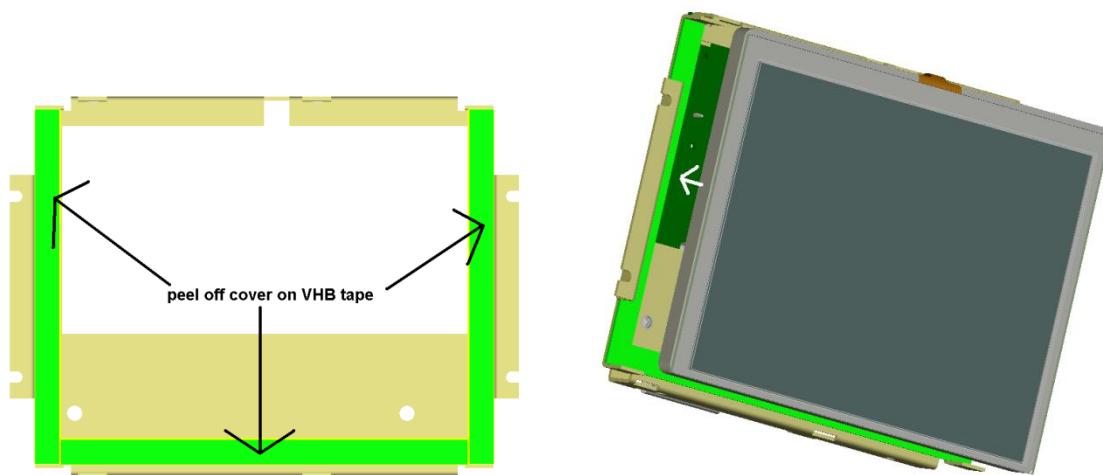

The UMSH8044 LCD is attached to the metalwork with 4 D3x6 POZI screws supplied, as shown

To minimise radiation, it is recommended that a good contact be made between the LCD metal cover and the support frame. This can most easily be achieved by applying a strip of conductive tape (or EMC screening gasket) around the periphery of the LCD to connect between the LCD cover and support frame.

After this, attach the Personality module to the back of the metal work as shown

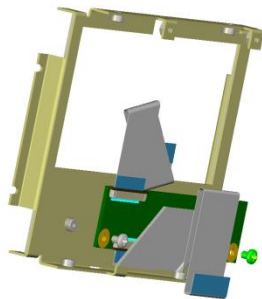

Note that to ease fitting, the 50 way FFC cables (connects the Personality Module to the RE1/RE2) should be folded and attached to the Personality module before assembly.

The UMSH8065 and UMSH8253 LCD's have a pre fitted FFC which connects to the Personality Module. The UMSH8044 (33way) UMSH8376 (40 way) and UMSH8173 (40 way) require an additional FFC in order to connect the LCD to the Personality Module

Use the 2 x M3x4 POZI screws supplied

The Personality Module – and the RE1/RE2 – is designed with 0V-reference pads around its mount-hole positions. This enables the reference ground of all the electronics PCBs (and the LCD metal cover) to be interconnected via the frame.

The FCC cables have been selected to enable maximum flexibility for evaluation. To minimise the risk of picking up (and re-radiating) noise on these cables, their routing should be carefully managed to avoid running close to the underside of the RE2 unit (it is generally good practice to avoid running unshielded, sensitive cables close to active electronics). Folding the FCC cables so that they are managed beneath the Personality Module (between it and the metal support frame) is one way to achieve this.

The FFC connectors are small and fragile so great care should be taken when fitting cables. The FFC cables are attached as follows

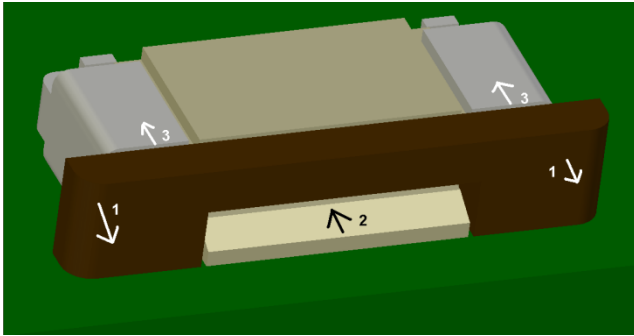

Step 1: carefully ease the brown section forward away from the connector body.

Step 2: insert the FFC cable (exposed connectors side down, blue on top) as shown

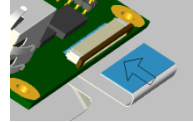

Step 3: push the brown section back to lock the cable in position

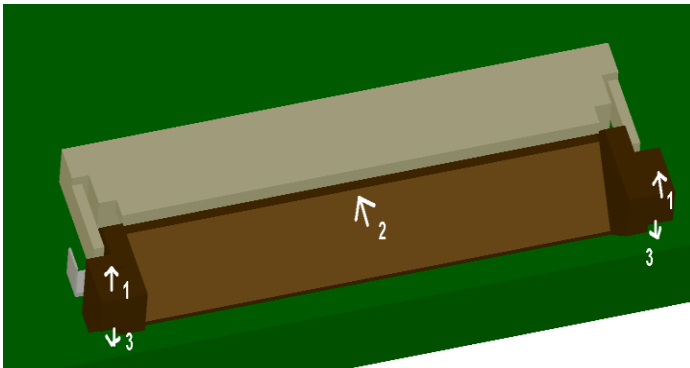

This connector is used with the UMSH134 LCD. Carefully lift the brown tab, and feed the FFC into the connector above this tab – the exposed connections should be upwards. Carefully lower the tab again to lock the cable in place.

This small connector is also used with the UMSH134 LCD.

Carefully lift the tab and insert the FFC cable below the tab (exposed connectors side down).

Lower the tab again to lock home

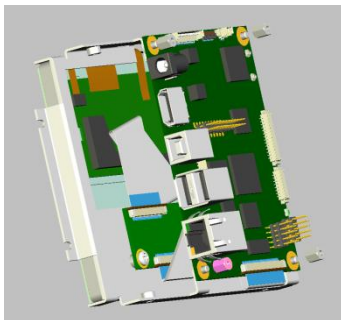
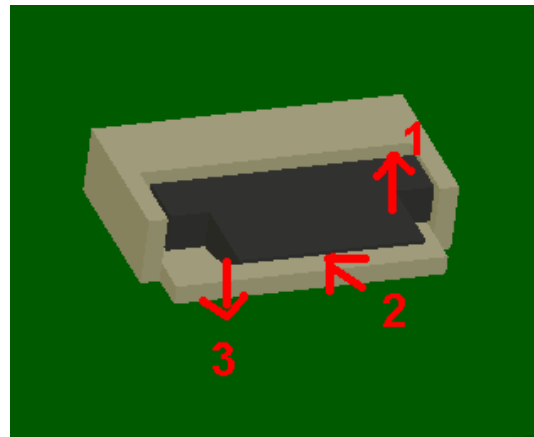

Next, fit the SD card, if supplied, and attach the RE1/RE2 board to the metal work using the M3x15 Spacers to secure in place. All other cables can be attached once the unit has been assembled

Note: Depending on the way the FFC cable has been folded and the orientation of the RE2 board on the rear of the metal work, it may be better to attach the 50 way FFC cable to the RE2 before attaching the board it to the metal work

The picture on the left shows the UMSH8376 assembly. The other assembly variants are shown below

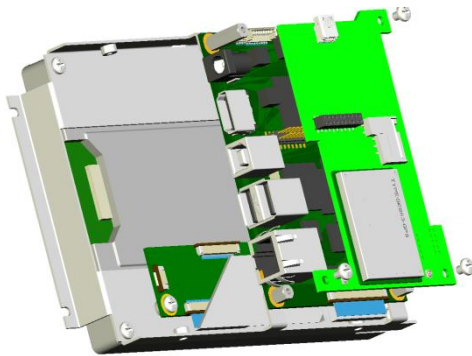
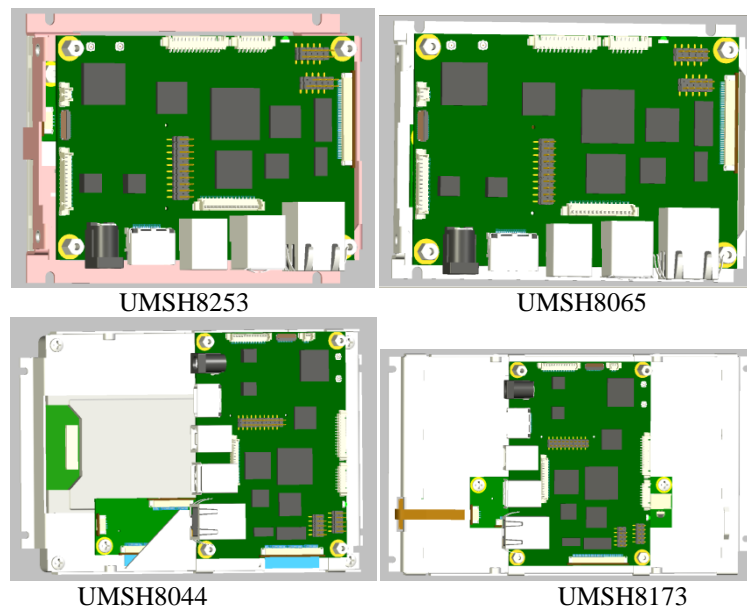

If the RE2 Communications module is to be attached, fit this before fitting the RE2 retaining spacer/screws. It is easily located onto RE2 as shown on the left

Without the Communication module, 4 x M3x15 Hex Spacers are required. With the Communication module, 4 x M3x6 Hex spacers are required and 3 x M3 x 4 Pan Head machine screws

Lastly fit the accessory cables as required.

The accessory cables have also been designed for flexibility of use as part of an evaluation kit. Good EMC practice is to arrange accessory cables to prevent them from running parallel, and in close proximity, to any active electronics, and also to connect connector shells to the same 0V reference as the rest of the assembly (eg: by using a metallic bracket with a low-impedance connection to the main mount-plate): this arrangement ensures that a suitable reference ground is provided for any attached cable screens, which both reduces the potential for radiated noise emissions, and also increases the resilience of the unit to external interference which may be coupled into attached, external cables.

Using the RE1/RE2

Once assembled, apply power and the RE2 is ready to go.

If required, the RE1 and RE2 User Guides provide details on setting up and configuring the RE1/RE2. A point to note is that for programming using the Configuration Utility, a standard USB “A to B” cable will be required. This type of cable is available from any PC accessory store.

RE2 Antennae Guide

For best operation Wi-Fi, Bluetooth, GPS and GSM all require the attachment of appropriate Antennae. The basic requirements for compatible antennae are as follows:

WiFi / Bluetooth

Frequency:	Impedance:
2.4GHz	50 ohm

GPS

Frequency:	Antenna:	Impedance:	Gain:
1575.42MHz (RX only)	DC feed available from nominal 3.8V DC/20mA	50 ohm	1.5dBi to 4.5dBi plus amplification up to 27dB (25dB typical recommended)

GSM/GPRS

Frequency:	Antenna:	Impedance:	Gain:	VSWR:
850/900MHz 1800/1900MHz	Must handle at least 2W peak power	50 ohm	<3dBi	<=10:1 (<=2:1 recommended)



To connect the Antennae to the RE2 or CM1 PCB's a High Frequency cable, such as shown on the left, is required.

The one tested by Blue Chip is from Samtec MH113 series of cables. The 01BJ1 end refers to a SMA Bulkhead Straight Jack connector; however this is available in other types to suit the Antenna chosen. The 0xxx part of the description refers to the cable length: typically these are 0050 (50mm), 0100 (100mm), 0150 (150mm) and 0300 (300mm).

See www.samtec.com for more details



A good all round choice for a compact antenna covering all of WiFi, Bluetooth and GSM/GPRS is shown on the left. This is a Siretta ANTA7000A0200BD1, and is approx 50mm in length. The Siretta ANTA7000S0200BD1 is similar length to this but is right angled. For better performance in the quad band GSM frequencies, the Siretta ANTG2000A0000AR1 is a suitable option.

See www.siretta.co.uk for more details on their product offerings.



For GPS, a good choice from testing is the Linx Tech ANT-GPS-SH-SMA. This has Magnetic attachment and a 3m cable length

See www.linxtechnologies.com for more details on their product offerings