

ETX-945GSE

Onboard Intel® Atom™ N270

Processor

Non-ECC DDRII 400/533 Memory

With LCD, Ethernet, PCI, ISA,

Audio, SATA, SDVO

Copyright Notice

This document is copyrighted, 2010. All rights are reserved. The original manufacturer reserves the right to make improvements to the products described in this manual at any time without notice.

No part of this manual may be reproduced, copied, translated, or transmitted in any form or by any means without the prior written permission of the original manufacturer. Information provided in this manual is intended to be accurate and reliable. However, the original manufacturer assumes no responsibility for its use, or for any infringements upon the rights of third parties that may result from its use.

The material in this document is for product information only and is subject to change without notice. While reasonable efforts have been made in the preparation of this document to assure its accuracy, AAEON assumes no liabilities resulting from errors or omissions in this document, or from the use of the information contained herein.

AAEON reserves the right to make changes in the product design without notice to its users.

Acknowledgments

All other products' name or trademarks are properties of their respective owners.

- Award is a trademark of Award Software International, Inc.
- Intel[®], and Atom[™] are trademarks of Intel[®] Corporation.
- Microsoft Windows[®] is a registered trademark of Microsoft Corp.
- WINBOND is a trademark of Winbond Electronics Corporation.
- IBM, PC/AT, PS/2, and VGA are trademarks of International Business Machines Corporation.

Please be notified that all other products' name or trademarks not be mentioned above are properties of their respective owners.

Packing List

Before you begin installing your card, please make sure that the following materials have been shipped:

- 1 ETX-945GSE CPU Module
- 1 CD-ROM for manual (in PDF format) and drivers

If any of these items should be missing or damaged, please contact your distributor or sales representative immediately.

Application Notes

1. After installing drivers in AT power mode under Windows® XP operation, there is no message: "It is now safe to turn off your computer" during the procedure of turn-off.
2. Hyper threading technology only supports ATX mode rather than AT mode.
3. If you are going to use the add-on PCI Video Card instead of the onboard Intel® 945GSE VGA function, you have to uninstall the onboard Intel® VGA driver before installing the driver of add-on PCI Video Card.
4. While installing OS into SATA HDD, please do not attach any IDE HDD during installation. If you need one IDE HDD as storage device, please attach IDE HDD after finishing the installation.
5. If using LCD by 800x480 pixel,
 - A. Please set LCD as primary
 - B. Operation procedure to run dual display or extended display under Window® XP:
 - a. Please use control panel -> display device-> adjust
 - b. Use right button of mouse to select
6. Under DOS mode, if setting simultaneous displays
 - A. 24-bit LVDS LCD (from Chrontel 7308) + VGA: the screen shrinks at any resolution.
 - B. 18-bit LVDS LCD + VGA: the screen shrinks at resolution 640x480.
7. DIO address is "200H."
8. Module can run without RTC battery.
9. Two options to select AT/ATX power mode
 - Auto switch circuit
 - SMT jumper
10. SDVOCTL_CLK & SDVOCTL_DATA are connected to 945GSE; SMBUS is connected to ICH7M; I2C bus is connected to Winbond SIO.

Contents

Chapter 1 General Information

1.1 Introduction.....	1-2
1.2 Features	1-3
1.3 Specifications	1-4

Chapter 2 Quick Installation Guide

2.1 Safety Precautions	2-2
2.2 Mechanical Drawing	2-3
2.3 List of Jumpers	2-4
2.4 List of Connectors	2-4
2.5 AT/ATX & Back Light Selection (JP1)	2-5
2.6 SDVO Extension Slot (CN2)	2-5
2.7 SPI Flash Programming Connector (Optional) (CN3).....	2-6
2.8 ETX Connector (X1A).....	2-6
2.9 ETX Connector (X1B).....	2-7
2.10 ETX Connector (X1C)	2-8
2.11 ETX Connector (X1D)	2-10

Chapter 3 Award BIOS Setup

3.1 System Test and Initialization.	3-2
3.2 Award BIOS Setup	3-3

Chapter 4 Driver Installation

4.1 Installation	4-3
------------------------	-----

Appendix A Programming The Watchdog Timer

A.1 Programming	A-2
A.2 W83627HG Watchdog Timer Initial Program	A-6

Appendix B I/O Information

B.1 I/O Address Map	B-2
B.2 1 st MB Memory Address Map	B-3
B.3 IRQ Mapping Chart.....	B-4
B.4 DMA Channel Assignments.....	B-4

Chapter

1

**General
Information**

1.1 Introduction

ETX-945GSE is able to equip with Intel® Atom™ N270 processor and has one 200-pin DDR II 400/533 SODIMM to support system memory up to 1GB. ETX-945GSE adopts Intel® 945GSE+ ICH7M chipset that implements serial technologies with high performance. In addition, ETX-945GSE accommodates user-friendly expansion interfaces, ex: four 32-bit PCI, one ISA bus, one SMBus and one I2C interface.

For the display specifications, ETX-945GSE integrates Intel® 945GSE and shared system memory is up to 224MB/DVMT 3.0. The display of ETX-945GSE supports CRT and 18/24-bit dual-channel LVDS LCD. Moreover, it supports NTSC/ PAL and Composite Video, S-Video on the carrier board. In addition, one SDVO port can be used through the SDVO connector to provide more flexibility for display function.

If you are looking for an economic, time-saving and high performance solution, ETX-945GSE definitely is your first choice.

1.2 Features

- Onboard Intel® Atom™ N270 Processor
- Intel® 945GSE + ICH7M
- DDRII 400/533 Memory, Max. 1GB
- 10/100Base-TX Ethernet
- CRT, Up to 24-bit Dual-channel LVDS LCD, TV, SDVO Connector x 1
- AC97 2.3 Codec 2CH Audio
- PATA x 1, SATA II x 2
- USB2.0 x 4
- +5V Only Operation

1.3 Specifications

System

- CPU Onboard Intel® Atom™ N270 Processor
1.6GHz, FSB 533MHz
- Memory One 200-pin DDR II SODIMM, supports
DDR II 400/533 up to 1GB, non ECC
function only
- Chipset Intel® 945GSE+ICH7M
- Ethernet Intel® EP82562ET, 10/100Base-TX
- BIOS Award, SPI type, 8 Mb ROM
- Watchdog Timer Generates a Time-out System Reset
- H/W Status Monitoring Supports Power Supply Voltages, Fan
Speed and Temperatures Monitoring
- Wake on LAN Yes
- Expansion Interface 32-bit PCI x 4
ISA Bus x 1
SMBus x 1
I2C x 1
- Power Supply Voltage +5V DC
- EEPROM Atmel AT24C02, SOP 8, 2Kb, Serial
EEPROM
- Board Size 4.5"(L) x 3.75"(W) (114mm x 95mm)
- Gross Weight 0.66lb (0.3kg)
- Operating Temperature 32°F~140°F (0°C~60°C)

- Storage Temperature -40°F~176°F (-40°C~80°C)
- OS Support Windows 32-bit XP Pro/ WinCE 6.0/
Windows XP Embedded/ Windows
32-bit Vista/ Linux Fedora

**Display: Supports CRT/LCD, CRT/TV, LCD/TV simultaneous/
dual view displays**

- Chipset Intel® 945GSE integrated
- Memory Shared system memory up to 224MB/
DVMT 3.0
- Resolution Up to 2048x1536 (QXGA) for CRT; Up to
1600x1200 (UXGA) for LCD
- LCD Interface 18-bit dual-channel LVDS
(TF-ETX-945GSE-A10);
24-bit dual-channel LVDS
(TF-ETX-945GSE-A10-01)
- SDVO Port SDVO port x 1
- TV-Out Intel 945GSE integrated, supports
NTSC/PAL;
HDTV support: 480p/720p/1080i
Supports Composite Video, S-Video on
the carrier board

I/O

- Storage PATA x 1 (two devices), SATA II x 2,

	Floppy Disk Drive x 1
● Serial Port	2
● Parallel Port	1
● USB	USB2.0 x 4
● GPIO	2
● PS/2 Port	Keyboard x 1, Mouse x 1
● IrDA	One IrDA Tx/Rx header
● Audio	Mic-in, Line-in, Line-out

Chapter

2

**Quick
Installation
Guide**



2.1 Safety Precautions

Warning!



Always completely disconnect the power cord from your board whenever you are working on it. Do not make connections while the power is on, because a sudden rush of power can damage sensitive electronic components.

Caution!



Always ground yourself to remove any static charge before touching the board. Modern electronic devices are very sensitive to static electric charges. Use a grounding wrist strap at all times. Place all electronic components on a static-dissipative surface or in a static-shielded bag when they are not in the chassis

2.2 Mechanical Drawing

Component Side

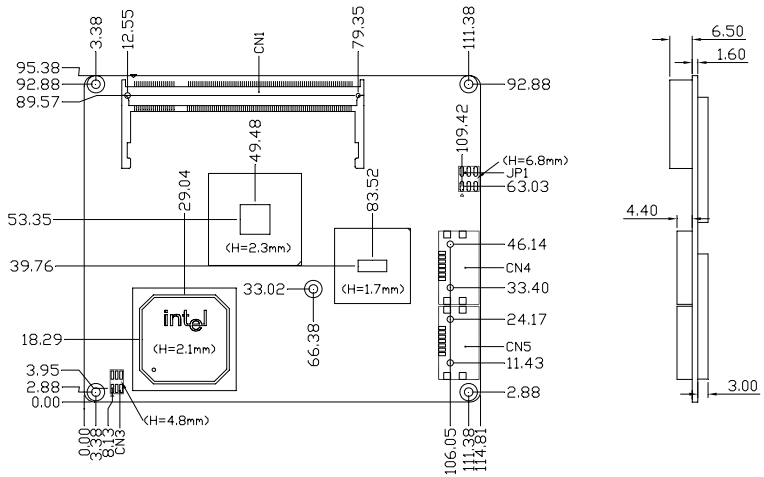

Solder Side

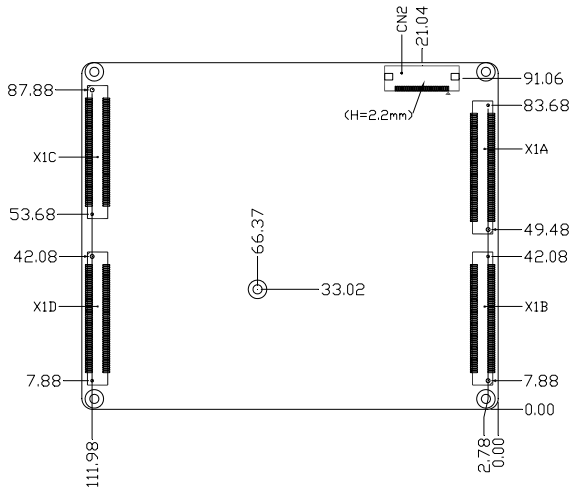

2.3 List of Jumpers

The board has a number of jumpers that allow you to configure your system to suit your application.

The table below shows the function of each of the board's jumpers:

Jumpers

Label	Function
JP1	AT/ATX & Back Light Selection

2.4 List of Connectors

The board has a number of connectors that allow you to configure your system to suit your application.

The table below shows the function of the board's connectors:

Connectors

Label	Function
CN1	DDRII SODIMM Slot
CN2	SDVO Extension Slot
CN3	SPI Flash Programming Connector (Optional)
CN4, CN5	SATA Connector
X1A	PCI / USB / Audio
X1B	ISA Signals
X1C	VGA / LCD / Video out / COMs / LPT / FDD / IrDA / Mouse / Keyboard
X1D	IDE 1 / IDE 2 / Miscellaneous

2.5 AT/ATX & Back Light Selection (JP1)

JP1	Function
1-3	AT mode
3-5	ATX mode (Default)
2-4	Back light high enable (Default)
4-6	Back light low enable

2.6 SDVO Extension Slot (CN2)

Pin	Signal	Pin	Signal
1	GND	2	SDVO_BCLKN
3	SDVO_BCLKP	4	GND
5	SDVO_GREEN#	6	SDVO_GREEN
7	GND	8	SDVO_INT#
9	SDVO_INT	10	GND
11	SDVO_BLUE#	12	SDVO_BLUE
13	GND	14	SDVO_RED#
15	SDVO_RED	16	GND
17	SDVO_FLDSTALL#	18	SDVO_FLDSTALL
19	GND	20	SDVOCTRL_CLK
21	SDVOCTRL_DATA	22	RESET#
23	+3.3V	24	+2.5V
25	+5V	26	GND
27	SDVO_TVCLKIN#	28	SDVO_TVCLKIN
29	+3.3V	30	+5V

2.7 SPI Flash Programming Connector (Optional) (CN3)

Pin	Signal	Pin	Signal
1	+3.3V	2	GND
3	SPI_CS#0	4	SPI_CLK
5	SPI_SO	6	SPI_SI

2.8 ETX Connector (X1A)

Pin	Signal	Pin	Signal	Pin	Signal	Pin	Signal
1	GND	2	GND	51	VCC	52	VCC
3	PCICLK3	4	PCICLK4	53	PAR	54	SERR#
5	GND	6	GND	55	PERR#	56	NC
7	PCICLK1	8	PCICLK2	57	PCI_PME	58	USB2N
9	REQ3#	10	GNT3#	59	PLOCK#	60	DEVSEL#
11	GNT2#	12	3V	61	TRDY#	62	USB3N
13	REQ2#	14	GNT1#	63	IRDY#	64	STOP#
15	REQ1#	16	3V	65	FRAME#	66	USB2P
17	GNT0#	18	NC	67	GND	68	GND
19	VCC	20	VCC	69	AD16	70	CBE2#
21	DREQ2 /SERIRQ	22	REQ0#	71	AD17	72	USB3P
23	AD0	24	3V	73	AD19	74	AD18
25	AD1	26	AD2	75	AD20	76	USB0N
27	AD4	28	AD3	77	AD22	78	AD21
29	AD6	30	AD5	79	AD23	80	USB1N
31	CBE0#	32	AD7	81	AD24	82	CBE3#
33	AD8	34	AD9	83	VCC	84	VCC
35	GND	36	GND	85	AD25	86	AD26
37	AD10	38	LIN_L	87	AD28	88	USB0P

39	AD11	40	MIC_IN	89	AD27	90	AD29
41	AD12	42	LIN_R	91	AD30	92	USB1P
43	AD13	44	VCCAUD	93	PCIRST#	94	AD31
45	AD14	46	LOUT_L	95	INTC#	96	INTD#
47	AD15	48	GNAUD	97	INTA#	98	INTB#
49	CBE1#	50	LOUT_R	99	GND	100	GND

2.9 ETX Connector (X1B)

Pin	Signal	Pin	Signal	Pin	Signal	Pin	Signal
1	GND	2	GND	51	VCC	52	VCC
3	SD14	4	SD15	53	SA6	54	IRQ5
5	SD13	6	MASTER#	55	SA7	56	IRQ6
7	SD12	8	DREQ7	57	SA8	58	IRQ7
9	SD11	10	DACK7#	59	SA9	60	SYSCLK
11	SD10	12	DREQ6	61	SA10	62	REFSH#
13	SD9	14	DACK6#	63	SA11	64	DREQ1
15	SD8	16	DREQ5	65	SA12	66	DACK1#
17	MEMW#	18	DACK#5	67	GND	68	GND
19	MEMR#	20	DREQ0	69	SA13	70	DREQ3
21	LA17	22	DACK0#	71	SA14	72	DACK3#
23	LA18	24	IRQ14	73	SA15	74	IOR#
25	LA19	26	IRQ15	75	SA16	76	LOW#
27	LA20	28	IRQ12	77	SA18	78	SA17
29	LA21	30	IRQ11	79	SA19	80	SMEMR#
31	LA22	32	IRQ10	81	IOCHRD	82	AEN
33	LA23	34	IO16#	83	VCC	84	VCC
35	GND	36	GND	85	SD0	86	SMEMW#
37	SBHE#	38	M16#	87	SD2	88	SD1

39	SA0	40	OSC	89	SD3	90	NOWS#
41	SA1	42	BALE	91	DREQ2	92	SD4
43	SA2	44	TC	93	SD5	94	IRQ9
45	SA3	46	DACK2#	95	SD6	96	SD7
47	SA4	48	IRQ3	97	IOCHK#	98	RSTDRV
49	SA5	50	IRQ4	99	GND	100	GND

2.10 ETX Connector (X1C)

Parallel Port Mode Pinout

Pin	Signal	Pin	Signal	Pin	Signal	Pin	Signal
1	GND	2	GND	51	LPT/FLPY#	52	NC
3	R	4	B	53	VCC	54	GND
5	HSY	6	G	55	STB#	56	AFD#
7	VSY	8	CRT_DDC CLK	57	NC	58	PD7
9	NC	10	CRT_DDC DAT	59	IRRX	60	ERR#
11	TXCLK1#	12	TXOUT13#	61	IRTX	62	PD6
13	TXCLK1	14	TXOUT13	63	RXD2	64	INIT#
15	GND	16	GND	65	GND	66	GND
17	TXOUT11	18	TXOUT12	67	RTS2#	68	PD5
19	TXOUT11#	20	TXOUT12#	69	DTR2#	70	SLIN#
21	GND	22	GND	71	DCD2#	72	PD4
23	TXOUT03##	24	TXOUT10	73	DSR2#	74	PD3
25	TXOUT03	26	TXOUT10#	75	CTS2#	76	PD2
27	GND	28	GND	77	TXD2#	78	PD1
29	TXOUT02##	30	TXCLK0	79	RI2#	80	PD0
31	TXOUT02	32	TXCLK0#	81	VCC	82	VCC
33	GND	34	GND	83	RXD1	84	ACK#

35	TXOUT00	36	TXOUT01	85	RTS1#	86	BUSY#
37	TXOUT00#	38	TXOUT01#	87	DTR1#	88	PE
39	VCC	40	VCC	89	DCD1#	90	SLCT#
41	LVDS_DDCPDATA	42	DVOCVSY NC	91	DSR1#	92	MSCLK
43	LVDS_DDCPCLK	44	LVDS_BK LEN	93	CCTS1#	94	MSDAT
45	LVDS_BKLCTL	46	LVDS_DIG ON	95	TXD1#	96	KBCLK
47	CVBS	48	Y	97	RI1#	98	KBDAT
49	CSYNC	50	C	99	GND	100	GND

Floppy Support Mode Pinout

Pin	Signal	Pin	Signal	Pin	Signal	Pin	Signal
1	GND	2	GND	51	LPT/FLPY#	52	NC
3	R	4	B	53	VCC	54	GND
5	HSY	6	G	55	NC	56	DENSEL
7	VSY	8	CRT_DDC CLK	57	NC	58	NC
9	NC	10	CRT_DDC DAT	59	IRRX	60	HDSEL#
11	TXCLK1#	12	TXOUT13#	61	IRTX	62	NC
13	TXCLK1	14	TXOUT13	63	RXD2	64	DIR#
15	GND	16	GND	65	GND	66	GND
17	TXOUT11	18	TXOUT12	67	RTS2#	68	NC
19	TXOUT11#	20	TXOUT12#	69	DTR2#	70	STEP#
21	GND	22	GND	71	DCD2#	72	DSKCHG#
23	TXOUT03##	24	TXOUT10	73	DSR2#	74	RDATA#
25	TXOUT03	26	TXOUT10#	75	CTS2#	76	WP#
27	GND	28	GND	77	TXD2#	78	TRKO#
29	TXOUT02##	30	TXCLK0	79	RI2#	80	INDEX#
31	TXOUT02	32	TXCLK0#	81	VCC	82	VCC

33	GND	34	GND	83	RXD1	84	DRV#
35	TXOUT00	36	TXOUT01	85	RTS1#	86	MOT#
37	TXOUT00#	38	TXOUT01#	87	DTR1#	88	WDATA#
39	VCC	40	VCC	89	DCD1#	90	WGATE#
41	LVDS_ DDCPDATA	42	DVOCVSY NC	91	DSR1#	92	MSCLK
43	LVDS_ DDCPCLK	44	LVDS_BKL EN	93	CCTS1#	94	MSDAT
45	LVDS_ BKLCTL	46	LVDS_DIG ON	95	TXD1#	96	KBCLK
47	CVBS	48	Y	97	RI1#	98	KBDAT
49	CSYNC	50	C	99	GND	100	GND

2.11 ETX Connector (X1D)

Pin	Signal	Pin	Signal	Pin	Signal	Pin	Signal
1	GND	2	GND	51	SIDE_IOW#	52	PIDE_IOR#
3	5V_SB	4	RSTIN#	53	SIDE_DRQ	54	PIDE_IOW#
5	PS_ON#	6	SPEAKER	55	SIDE_D15	56	PIDE_DRQ
7	PWRBTN#	8	BAT	57	SIDE_D0	58	PIDE_D15
9	FAN_TAC	10	LILED	59	SIDE_D14	60	PIDE_D0
11	NC	12	ACTLED	61	SIDE_D1	62	PIDE_D14
13	NC	14	SPEEDLED	63	SIDE_D13	64	PIDE_D1
15	NC	16	I2CLK	65	GND	66	GND
17	VCC	18	VCC	67	SIDE_D2	68	PIDE_D13
19	DACK2/ OVCR#	20	GPIO0	69	SIDE_D12	70	PIDE_D2
21	EXTSMI#	22	I2DAT	71	SIDE_D3	72	PIDE_D12
23	SMBCLK	24	SMBDATA	73	SIDE_D11	74	PIDE_D3
25	SIDE_CS3#	26	CPUFAN/ NC	75	SIDE_D4	76	PIDE_D11

27	SIDE_CS1#	28	VCC	77	SIDE_D10	78	PIDE_D4
29	SIDE_A2	30	PIDE_CS3#	79	SIDE_D5	80	PIDE_D10
31	SIDE_A0	32	PIDE_CS1#	81	VCC	82	VCC
33	GND	34	GND	83	SIDE_D9	84	PIDE_D5
35	P66DET/ S66DET	36	PIDE_A2	85	SIDE_D6	86	PIDE_D9
37	SIDE_A1	38	PIDE_A0	87	SIDE_D8	88	PIDE_D6
39	SIDE_INTR Q	40	PIDE_A1	89	RING#	90	P66DET
41	S66DET/ NC	42	NC	91	RXD#	92	PIDE_D8
43	SIDE_ACK #	44	PIDE_INTR Q	93	RXD	94	SIDE_D7
45	SIDE_RDY	46	PIDE_ACK #	95	TXD#	96	PIDE_D7
47	SIDE_IOR#	48	PIDE_RDY	97	TXD	98	HDRST#
49	VCC	50	VCC	99	GND	100	GND

Below Table for China RoHS Requirements

产品中有毒有害物质或元素名称及含量

AAEON Main Board/ Daughter Board/ Backplane

部件名称	有毒有害物质或元素					
	铅 (Pb)	汞 (Hg)	镉 (Cd)	六价铬 (Cr(VI))	多溴联苯 (PBB)	多溴二苯醚 (PBDE)
印刷电路板 及其电子组件	×	○	○	○	○	○
外部信号 连接器及线材	×	○	○	○	○	○
<p>O: 表示该有毒有害物质在该部件所有均质材料中的含量均在 SJ/T 11363-2006 标准规定的限量要求以下。</p> <p>X: 表示该有毒有害物质至少在该部件的某一均质材料中的含量超出 SJ/T 11363-2006 标准规定的限量要求。</p> <p>备注: 此产品所标示之环保使用期限, 系指在一般正常使用状况下。</p>						

Chapter

3

**Award
BIOS Setup**

3.1 System Test and Initialization

These routines test and initialize board hardware. If the routines encounter an error during the tests, you will either hear a few short beeps or see an error message on the screen. There are two kinds of errors: fatal and non-fatal. The system can usually continue the boot up sequence with non-fatal errors. Non-fatal error messages usually appear on the screen along with the following instructions:

Press <F1> to RESUME

Write down the message and press the F1 key to continue the boot up sequence.

System configuration verification

These routines check the current system configuration against the values stored in the CMOS memory. If they do not match, the program outputs an error message. You will then need to run the BIOS setup program to set the configuration information in memory.

There are three situations in which you will need to change the CMOS settings:

1. You are starting your system for the first time
2. You have changed the hardware attached to your system
3. The CMOS memory has lost power and the configuration information has been erased.

The ETX-945GSE memory has an integral lithium battery backup for data retention. However, you will need to replace the complete unit when it finally runs down.

3.2 Award BIOS Setup

Awards BIOS ROM has a built-in Setup program that allows users to modify the basic system configuration. This type of information is stored in battery-backed CMOS RAM so that it retains the Setup information when the power is turned off.

Entering setup

Power on the computer and press immediately. This will allow you to enter Setup.

Standard CMOS Features

Use this menu for basic system configuration. (Date, time, IDE, etc.)

Advanced BIOS Features

Use this menu to set the advanced features available on your system.

Advanced Chipset Features

Use this menu to change the values in the chipset registers and optimize your system performance.

Integrated Peripherals

Use this menu to specify your settings for integrated peripherals. (Primary slave, secondary slave, keyboard, mouse etc.)

Power Management Setup

Use this menu to specify your settings for power management. (HDD power down, power on by ring etc.)

PnP/PCI Configurations

This entry appears if your system supports PnP/PCI.

PC Health Status

This menu shows you the status of PC.

Frequency/Voltage Control

This menu shows you the display of frequency/Voltage Control.

Load Fail-Safe Defaults

Use this menu to load the BIOS default values for the minimal/stable performance for your system to operate.

Load Optimized Defaults

Use this menu to load the BIOS default values that are factory settings for optimal performance system operations. While AWARD has designated the custom BIOS to maximize performance, the factory has the right to change these defaults to meet their needs.

Set Supervisor/User Password

Use this menu to set Supervisor/User Passwords.

Save and Exit Setup

Save CMOS value changes to CMOS and exit setup.

Exit Without Saving

Abandon all CMOS value changes and exit setup.

For more detailed information, you can refer to the "AAEON BIOS Item Description.pdf" file in the CD for the meaning of each setting in this chapter.

Chapter

4

**Driver
Installation**

The ETX-945GSE comes with a CD-ROM that contains all drivers and utilities that meet your needs.

Follow the sequence below to install the drivers:

- Step 1 – Install INF Driver
- Step 2 – Install VGA Driver
- Step 3 – Install LAN Driver
- Step 4 – Install Audio Driver
- Step 5 – Install TPM Driver

USB 2.0 Drivers are available for download using Windows Update for both Windows XP and Windows 2000. For additional information regarding USB 2.0 support in Windows XP and Windows 2000, please visit www.microsoft.com/hwdev/usb/.

Please read instructions below for further detailed installations.

4.1 Installation:

Insert the ETX-945GSE CD-ROM into the CD-ROM Drive. And install the drivers from Step 1 to Step 5 in order.

Step 1 – Install INF Driver

1. Click on the **Step 1 - INF** folder and then double click on the **Setup.exe**
2. Follow the instructions that the window shows
3. The system will help you install the driver automatically

Step 2 – Install VGA Driver

1. Click on the **Step 2 - VGA** folder and select the folder of OS your system is
2. Double click on the **Setup.exe** file located in each OS folder
3. Follow the instructions that the window shows
4. The system will help you install the driver automatically

Step 3 – Install LAN Driver

1. Click on the **Step 3 - LAN** folder and select the folder of OS your system is
2. Double click on the **.exe** file located in each OS folder
3. Follow the instructions that the window shows
4. The system will help you install the driver automatically

Step 4 – Install Audio Driver

1. Click on the **Step 4 - Audio** folder and select the folder of

OS your system is

2. Double click on the **.exe** file located in each OS folder
3. Follow the instructions that the window shows
4. The system will help you install the driver automatically

Step 5 – Install TPM Driver

1. Click on the **Step 5 – TPM** folder and double click on the **Setup.exe**
2. Follow the instructions that the window shows
3. The system will help you install the driver automatically

Appendix

A

Programming the Watchdog Timer

A.1 Programming

ETX-945GSE utilizes W83627HG chipset as its watchdog timer controller.

Below are the procedures to complete its configuration and the AAEMON initial watchdog timer program is also attached based on which you can develop customized program to fit your application.

Configuring Sequence Description

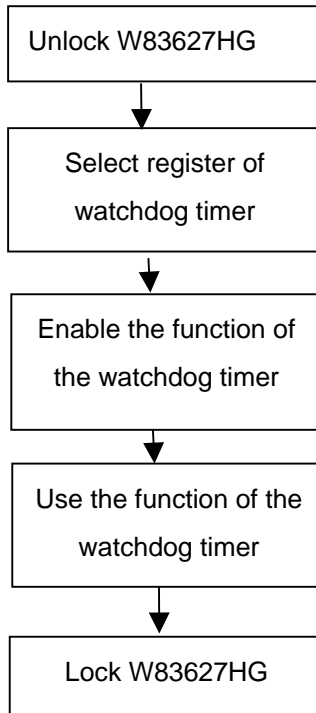

There are three steps to complete the configuration setup:

- (1) Enter the W83627HG config Mode
- (2) Modify the data of configuration registers

- (3) Exit the W83627HG config Mode. Undesired result may occur if the config Mode is not exited normally.

(1) Enter the W83627HG config Mode

To enter the W83627HG config Mode, two special I/O write operations are to be performed during Wait for Key state. To ensure the initial state of the key-check logic, it is necessary to perform two write operations to the Special Address port (2EH). The different enter keys are provided to select configuration ports (2Eh/2Fh) of the next step.

	Address Port	Data Port
87h,87h:	2Eh	2Fh

(2) Modify the Data of the Registers

All configuration registers can be accessed after entering the config Mode. Before accessing a selected register, the content of Index 07h must be changed to the LDN to which the register belongs, except some Global registers.

(3) Exit the W83627HG config Mode

The exit key is provided to select configuration ports (2Eh/2Fh) of the next step.

	Address Port	Data Port
0aah:	2Eh	2Fh

WatchDog Timer Register I (Index=F5h, Default=00h)

CRF5 (PLED mode register. Default 0 x 00)

Bit 7-6 : select PLED mode

= 00 Power LED pin is tri-stated.

= 01 Power LED pin is driven low.

= 10 Power LED pin is a 1Hz toggle pulse with 50 duty cycle.

= 11 Power LED pin is a 1/4Hz toggle pulse with 50 duty cycle.

Bit 5-4 : Reserved

Bit 3 : select WDTO count mode.

= 0 second

= 1 minute

Bit 2 : Enable the rising edge of keyboard Reset (P20) to force Time-out event.

= 0 Disable

= 1 Enable

Bit 1-0 : Reserved

WatchDog Timer Register II (Index=F6h, Default=00h)

Bit 7-0 = 0 x 00 Time-out Disable

= 0 x 01 Time-out occurs after 1
second/minute

= 0 x 02 Time-out occurs after 2
second/minutes

= 0 x 03 Time-out occurs after 3
second/minutes

.....

= 0 x FF Time-out occurs after 255
second/minutes

WatchDog Timer Register III (Index=F7h, Default=00h)

- Bit 7** : Mouse interrupt reset Enable or Disable
- = 1 Watchdog Timer is reset upon a Mouse interrupt
 - = 0 Watchdog Timer is not affected by Mouse interrupt
- Bit 6** : Keyboard interrupt reset Enable or Disable
- = 1 Watchdog Timer is reset upon a Keyboard interrupt
 - = 0 Watchdog Timer is not affected by Keyboard interrupt
- Bit 5** : Force Watchdog Timer Time-out. Write Only
- = 1 Force Watchdog Timer time-out event: this bit is self-clearing
- Bit 4** : Watchdog Timer Status. R/W
- = 1 Watchdog Timer time-out occurred
 - = 0 Watchdog Timer counting
- Bit 3-0** : These bits select IRQ resource for Watchdog. Setting of 2 selects SMI.

A.2 W83627HG Watchdog Timer Initial Program

Example: Setting 10 sec. as Watchdog timeout interval

```
;/;;;;;;;;;;;;;;;;;;;;;;;;;;;;;;;;;;;;;;;;;;;;;;;;;;;;;;;;;;;;;;;;;;;;;;;;;;;;;;;;;;;;;;;;;;;;;;;;;;;;;;;;;;;;;;;;;;;;;;;;;;;;;;;;
```

```
Mov dx,2eh           ;Enter W83627HG config mode
```

```
Mov al,87h          (out 87h to 2eh twice)
```

```
Out dx,al
```

```
Out dx,al
```

```
;/;;;;;;;;;;;;;;;;;;;;;;;;;;;;;;;;;;;;;;;;;;;;;;;;;;;;;;;;;;;;;;;;;;;;;;;;;;;;;;;;;;;;;;;;;;;;;;;;;;;;;;;;;;;;;;;;;;;;;;;;;;;;;;;;
```

```
Mov al,07h
```

```
Out dx,al
```

```
Inc dx
```

```
Mov al,08h          ;Select Logical Device 8 (GPIO Port  
2)
```

```
Out dx,al
```

```
;/;;;;;;;;;;;;;;;;;;;;;;;;;;;;;;;;;;;;;;;;;;;;;;;;;;;;;;;;;;;;;;;;;;;;;;;;;;;;;;;;;;;;;;;;;;;;;;;;;;;;;;;;;;;;;;;;;;;;;;;;;;;;;;;;
```

```
Dec dx
```

```
Mov al,30h          ;CR30 (GP20~GP27)
```

```
Out dx,al
```

```
Inc dx
```

```
Mov al,01h          ;Activate GPIO2
```

```
Out dx,al
```

```

;/////////////////////////////////////////////////////////////////
Dec dx
Mov al,0f5h           ;CRF5 (PLED mode register)
Out dx,al
Inc dx
In al,dx
And al,not 08h       ;Set second as counting unit
Out dx,al
;/////////////////////////////////////////////////////////////////
Dec dx
Mov al,0f6h           ; CRF6
Out dx,al
Inc dx
Mov al,10             ;Set timeout interval as 10 sec.
Out dx,al
;/////////////////////////////////////////////////////////////////
Dec dx                 ;Exit W83627HG config mode
Mov al,0aah           (out 0aah to 2eh once)
Out dx,al
;/////////////////////////////////////////////////////////////////

```

Appendix

B

I/O Information

B.1 I/O Address Map

Address Range	Device Name
[00000000 - 0000000F]	Direct memory access controller
[00000000 - 00000CF7]	PCI bus
[00000010 - 0000001F]	Motherboard resources
[00000020 - 00000021]	Programmable interrupt controller
[00000022 - 0000003F]	Motherboard resources
[00000040 - 00000043]	System timer
[00000044 - 0000004D]	Motherboard resources
[00000050 - 0000005E]	Motherboard resources
[00000061 - 00000061]	System speaker
[00000062 - 00000063]	Motherboard resources
[00000065 - 0000006F]	Motherboard resources
[00000070 - 00000073]	System CMOS/real time clock
[00000074 - 0000007F]	Motherboard resources
[00000080 - 00000090]	Direct memory access controller
[00000091 - 00000093]	Motherboard resources
[00000094 - 0000009F]	Direct memory access controller
[000000A0 - 000000A1]	Programmable interrupt controller
[000000A2 - 000000BF]	Motherboard resources
[000000C0 - 000000DF]	Direct memory access controller
[000000E0 - 000000EF]	Motherboard resources
[000000F0 - 000000FF]	Numeric data processor
[00001F0 - 00001F7]	Primary IDE Channel
[00000274 - 00000277]	ISAPNP Read Data Port
[00000279 - 00000279]	ISAPNP Read Data Port
[00000294 - 00000297]	Motherboard resources
[000002E8 - 000002EF]	Communications Port (COM4)
[000002F8 - 000002FF]	Communications Port (COM2)
[000003B0 - 000003BB]	Mobile Intel(R) 945 Express Chipset Family
[000003C0 - 000003DF]	Mobile Intel(R) 945 Express Chipset Family
[000003E8 - 000003EF]	Communications Port (COM3)
[000003F0 - 000003F5]	Standard floppy disk controller
[000003F6 - 000003F6]	Primary IDE Channel
[000003F7 - 000003F7]	Standard floppy disk controller
[000003F8 - 000003FF]	Communications Port (COM1)
[00000400 - 000004BF]	Motherboard resources
[000004D0 - 000004D1]	Motherboard resources
[00000500 - 0000051F]	Intel(R) 82801G (ICH7 Family) SMBus Controller - 27DA
[00000880 - 0000088F]	Motherboard resources
[00000A78 - 00000A7B]	Motherboard resources
[00000B78 - 00000B7B]	Motherboard resources
[00000B8C - 00000B8F]	Motherboard resources
[00000D00 - 0000FFFF]	PCI bus
[00000E78 - 00000E7B]	Motherboard resources
[00000F78 - 00000F7B]	Motherboard resources
[00000FBC - 00000FBF]	Motherboard resources
[0000DF00 - 0000DF3F]	Intel(R) PRO/100 VE Network Connection
[0000F000 - 0000F0FF]	Realtek AC'97 Audio
[0000F300 - 0000F30F]	Intel(R) 82801GBM/GHM (ICH7-M Family) Serial ATA Storage Controller - 27C4
[0000F400 - 0000F403]	Intel(R) 82801GBM/GHM (ICH7-M Family) Serial ATA Storage Controller - 27C4
[0000F500 - 0000F507]	Intel(R) 82801GBM/GHM (ICH7-M Family) Serial ATA Storage Controller - 27C4
[0000F600 - 0000F603]	Intel(R) 82801GBM/GHM (ICH7-M Family) Serial ATA Storage Controller - 27C4
[0000F700 - 0000F707]	Intel(R) 82801GBM/GHM (ICH7-M Family) Serial ATA Storage Controller - 27C4
[0000F800 - 0000F80F]	Intel(R) 82801G (ICH7 Family) Ultra ATA Storage Controllers - 27DF
[0000FA00 - 0000FA3F]	Realtek AC'97 Audio
[0000FD00 - 0000FD1F]	Intel(R) 82801G (ICH7 Family) USB Universal Host Controller - 27C9
[0000FE00 - 0000FE1F]	Intel(R) 82801G (ICH7 Family) USB Universal Host Controller - 27C8
[0000FF00 - 0000FF07]	Mobile Intel(R) 945 Express Chipset Family

B.2 1st MB Memory Address Map

Address Range	Device
[00000000 - 0009FFFF]	System board
[000A0000 - 000BFFFF]	Mobile Intel(R) 945 Express Chipset Family
[000A0000 - 000BFFFF]	PCI bus
[000C0000 - 000DFFFF]	PCI bus
[000E0000 - 000EFFFF]	System board
[000F0000 - 000FFFFF]	System board
[00100000 - 1F6DFFFF]	System board
[1F6E0000 - 1F6FFFFF]	System board
[1F750000 - FEBFFFFF]	PCI bus
[D0000000 - DFFFFFFF]	Mobile Intel(R) 945 Express Chipset Family
[E0000000 - EFFFFFFF]	Motherboard resources
[FDCFF000 - FDCFFFFF]	Intel(R) PRO/100 VE Network Connection
[FDF00000 - FDF7FFFF]	Mobile Intel(R) 945 Express Chipset Family
[FDF80000 - FDFBFFFF]	Mobile Intel(R) 945 Express Chipset Family
[FDFFC000 - FDFFC3FF]	Intel(R) 82801GBM/GHM (ICH7-M Family) Serial ATA Storage Controller - 27C4
[FDFFD000 - FDFFD0FF]	Realtek AC'97 Audio
[FDFFE000 - FDFFE1FF]	Realtek AC'97 Audio
[FDFFF000 - FDFFF3FF]	Intel(R) 82801G (ICH7 Family) USB2 Enhanced Host Controller - 27CC
[FEB80000 - FEBFFFFF]	Mobile Intel(R) 945 Express Chipset Family
[FEC00000 - FEC00FFF]	System board
[FED13000 - FED1DFFF]	System board
[FED20000 - FED3FFFF]	System board
[FED40000 - FED44FFF]	PCI bus
[FED45000 - FED8FFFF]	System board
[FEE00000 - FEE00FFF]	System board
[FFB80000 - FFB7FFFF]	System board
[FFB80000 - FFB7FFFF]	Intel(R) 82802 Firmware Hub Device
[FFF00000 - FFFFFFFF]	System board

B.3 IRQ Mapping Chart

IRQ	Device
(ISA) 0	System timer
(ISA) 3	Communications Port (COM2)
(ISA) 4	Communications Port (COM1)
(ISA) 6	Standard floppy disk controller
(ISA) 8	System CMOS/real time clock
(ISA) 9	Microsoft ACPI-Compliant System
(ISA) 10	Communications Port (COM3)
(ISA) 11	Communications Port (COM4)
(ISA) 13	Numeric data processor
(ISA) 14	Primary IDE Channel
(PCI) 15	Intel(R) 82801G (ICH7 Family) SMBus Controller - 27DA
(PCI) 16	Mobile Intel(R) 945 Express Chipset Family
(PCI) 17	Realtek AC'97 Audio
(PCI) 19	Intel(R) 82801G (ICH7 Family) USB Universal Host Controller - 27C9
(PCI) 19	Intel(R) 82801GBM/GHM (ICH7-M Family) Serial ATA Storage Controller - 27C4
(PCI) 20	Intel(R) PRO/100 VE Network Connection
(PCI) 23	Intel(R) 82801G (ICH7 Family) USB Universal Host Controller - 27C8
(PCI) 23	Intel(R) 82801G (ICH7 Family) USB2 Enhanced Host Controller - 27CC

Memory

B.4 DMA Channel Assignments

DMA Channel	Device
2	Standard floppy disk controller
4	Direct memory access controller

Input/output (IO)
Interrupt request (IRQ)
Memory