



Vario E2

Small Form-Factor PC

User Guide

Document Reference: Product User Guide

Document Issue: 1.0

## Contents

Copyright .....	4
Limitations of Liability .....	4
Trademarks .....	4
Regulatory Statements .....	5
Safety Warning for North America .....	5
Manual Organisation .....	6
Introduction .....	7
Specification .....	8
General Precautions .....	10
PS/2 Devices .....	10
Electro-Static Discharges .....	10
On-Board Battery .....	10
BIOS & CMOS Memory .....	11
Electromagnetic Compatibility .....	11
Quick Start .....	12
Board Layout .....	<b>Error! Bookmark not defined.</b>
Jumpers .....	13
CMOS Clear .....	13
Front Panel Connector .....	14
External Connections .....	14
Audio .....	14
Upgrading Hardware .....	15
Warning .....	15
Upgrade Options .....	15
Adding / Upgrading Memory .....	16
Upgrading/Changing the CPU .....	17
Changing a Chassis Fan .....	18
Replacing the Optical Drive .....	20
Replacing the HDD .....	20
Replacing the On/Off Switch Assembly .....	21
Replacing/Fitting Optional Expansion Cards .....	21
Removing the PSU .....	22
Installing Operating Systems .....	23
BIOS Setup .....	24
Main Menu .....	24
System Information .....	26

Advanced BIOS Features .....	27
Fox Central Control Unit .....	28
Advanced Chipset Features .....	29
Integrated Peripherals .....	30
Power Management Setup .....	30
PC Health Status .....	31
BIOS Security Features .....	32
Maintenance.....	33
Replacing the Battery .....	33
Fuses .....	33
Amendment History .....	34

## **Copyright**

All rights reserved. No part of this publication may be reproduced, stored in any retrieval system, or transmitted, in any form or by any means, electronic, mechanical, photocopied, recorded or otherwise, without the prior permission, in writing, from the publisher. For permission in the UK please contact Blue Chip Technology.

Information offered in this manual is believed to be correct at the time of printing. Blue Chip Technology accepts no responsibility for any inaccuracies. The information contained herein is subject to change without notice. There are no express or implied licences granted herein to any intellectual property rights of Blue Chip Technology Ltd.

## **Limitations of Liability**

In no event shall Blue Chip Technology be held liable for any loss, expenses or damages of any kind whatsoever, whether direct, indirect, incidental or consequential, arising from the design or use of this product or the support materials supplied with this product. If this product proves to be defective, Blue Chip Technology is only obliged to replace or refund the purchase price at Blue Chip Technology's discretion according to their Terms and Conditions of Sale.

## **Trademarks**

All trademarks and registered names acknowledged.

IBM, PC, AT and PS/2 are trademarks of International Business Machines Corporation (IBM).

AMD is a registered trademark of Advanced Micro Devices Inc.

All Athlon processors are registered trademarks of Advanced Micro Devices Inc.

GeForce and nForce are registered trademarks of the NVIDIA Corporation

SoundMAX is a registered trademark of Advanced Micro Devices Inc.

AMI is a registered trademark of American Megatrends Inc.

MSDOS and WINDOWS are registered trademarks of the Microsoft Corporation.

## **Regulatory Statements**

CE

This product meets the essential protection requirements of the European EMC Directive (89/336/EEC) and its amending Directives, and the Low Voltage Directive 73/23/EEC, and is eligible to bear the CE mark.

**Warning**

This is a Class A product. In a domestic environment this product may cause radio interference in which case the user may be required to take adequate measures.

FCC

NOTE:

This equipment has been tested and found to comply with the limits for a Class A digital device, pursuant to Part 15 of the FCC Rules. These limits are designed to provide reasonable protection against harmful interference when the equipment is operated in a commercial environment. This equipment generates, uses, and can radiate radio frequency energy and if not installed and used in accordance with the instruction manual, may cause harmful interference to radio communications. Operation of this equipment in a residential area is likely to cause harmful interference in which case the user will be required to correct the interference at his own expense.

WARNING:

Changes or modifications not expressly approved by the manufacturer could void the user's authority to operate the equipment.

## **Safety Warning for North America**

If the power lead (cord) is not supplied with the computer, select a power lead according to your local electrical regulations. In the USA use a 'UL listed' lead. In Canada use a CSA approved or 'cUL listed' lead.

Si le cordon secteur n'est pas livré avec l'ordinateur, utiliser un cordon secteur en accord avec votre code électrique nationale. En l'Etat Unis utiliser un cordon secteur 'UL listed'. En Canada utiliser un cordon secteur certifié CSA, ou 'cUL listed'.

## **Manual Organisation**

This manual describes in detail the Vario E2 Small Form-Factor PC.

We have tried to include as much information as possible but we have not duplicated information that is provided in the standard IBM Technical References, unless it proved to be necessary to aid in the understanding of the product.

The manual is sectioned as follows:

Introduction;

Overview, listing the unit's features and specification;

Installation, including what software to install

Layout, showing where the various connectors are located, and their pin-out details;

How to upgrade the system;

Bios Setup

Maintenance details.

We strongly recommend that you study this manual carefully before attempting to interface with the XXXX or change the standard configurations. Whilst all the necessary information is available in this manual we would recommend that unless you are confident, you contact your supplier for guidance. ***IT IS PARTICULARLY IMPORTANT THAT YOU READ THE SECTION 'PRECAUTIONS' BEFORE HANDLING ANY COMPONENTS INSIDE THE UNIT.***

If you have any suggestions or find any errors concerning this manual and want to inform us of these, please contact our Technical Services department with the relevant details.

## **Introduction**

The VARIO E2 is a powerful slim-line AMD Socket AM2 based Personal Computer (PC) specifically designed to drive large plasma and other large displays panels. The unit is self-contained requiring as a minimum, only a power connection and a display. The applications are not limited to display applications: it may be used as a general purpose PC.

The basic unit comprises a highly integrated computer board employing the AMD 780G Northbridge and AMD SB700 Southbridge chipsets which supports AMD socket AM2+ Phenom series processors as well as AM2 for Athlon™ 64FX / Athlon™ 64 X2 / Athlon™ 64 / Sempron processors with 2000/1600 MT/s front side bus (FSB). Memory options allow up to 8GB of ultra fast 1066/800/667 MHz unbuffered ECC/ non-ECC DDR2 SDRAM. Storage is provided by a single 3½-inch Serial ATA II 3Gb/s hard disk drive.

The on-board AMD 780G GPU supports Microsoft® DirectX 10.0, dual VGA out (RGB and DVI-D/HDMI), with unprecedented integrated video quality, including AMD UVD with support for Blue-Ray and HD-DVD content. In built PCIe Generation 2.0 support and ATI Hybrid graphics technology allow increased system performance by enabling the ability for the integrated graphics and discrete graphics to render simultaneously.

Removable media options include a slim-line DVD-ROM IDE drive.

The unit is housed in a strong sheet-steel enclosure providing both mechanical and EMC protection. Fans draw cooling air into the unit and direct it through the chassis to ensure a wide operating temperature range. The unit may be mounted on the plasma display, or separately to suit the particular installation. Mounting kits are available for specific plasma displays, wall or desktop, as well as 19" Rack.

Most connectors are on the front face of the chassis. There are connectors for a PS/2 mouse and keyboard, a standard analogue VGA display, a standard Digital Display, a HDMI interface, one serial port, four USB (2.0) ports, an Ethernet (10/100/1Gb) LAN port, and 8-channel analogue or digital audio connectors. The on-board audio system may be configured from simple stereo to a full 7.1 surround system, and from analogue jacks, to High Definition Audio with multi-streaming support.

Additional I/O capability can be provided by the following

- an optional PCI Express x 16 expansion card,
- an optional short 32-bit PCI (2.2) expansion card

The above I/O is configurable at time of order only.

The AC power inlet connector is at the rear of the chassis. The power supply unit is auto-ranging to cover most markets.

External indicators and controls on the front face of the chassis are limited to a hard drive activity LED, a power on LED and a power/standby push-button switch. The LAN connector also includes LEDs indicating a connection and data rate.

**Specification**

CPU:	AMD Athlon™ 64; AMD Athlon™ 64 X2
Chipset:	Northbridge: AMD 780G Southbridge: AMD SB700
Graphics Controller:	Integrated in the AMD 780G GPU Dual Output: RGB, DVI-D/HDMI Maximum resolution of 1920x1080p for HDMI display Picture rotation 0, 90, 180, 270 degrees
BIOS:	8Mb Flash EEPROM with LAN Boot, PnP, ACPI, WfM, DMI
Memory:	Dual Channel memory Architecture 4 x 240-pin DIMM sockets supporting up to 8GB of unbuffered ECC/non-ECC 1066/800/667 MHz DDR2 memory modules
LAN	Realtek RTL8111B, supporting 10/100/1Gb rates
Audio:	Realtek ALC888GR 7.1-channel CODEC supporting Jack sensing technology, and High Definition Audio
Expansion:	One 32-bit PCI v2.2 slot riser card for short PCI expansion card. Maximum card length to rear face of card 175mm One PCI-Express x 16 slot riser card. Maximum card length 175mm
Primary Storage:	One 3½" SATA II hard disk drive
Secondary Storage:	Single slim-line drive bay supports optional IDE slim-line DVD-R/W drive
External I/O:	PS/2 Keyboard Connector PS/2 Mouse Connector Standard VGA connector Digital DVI-D connector HDMI connector 9-way Serial connector (16550 compatible) RJ-45 10/100/1Gb Base-T Ethernet LAN connector 6 x Audio Ports 4 x USB 2.0 connectors
Indicators:	Power On LED, Hard Drive Activity LED
Control:	Power Standby push button switch
Watchdog:	Optional: Programmable timer, 2.4 to 37 seconds
System Management:	CPU & System temperature monitoring Voltage monitoring of CPU Core, DRAM, NB, +3.3V, 12.0V
Power Requirements:	Auto Ranging 115-230V / 4 -2A /60 -50Hz, with IEC320 power inlet

Environmental Conditions:                      Operating temperature range +0°C <sup>1</sup> to +50°C <sup>2</sup> in free air  
Storage temperature range -20°C to +70°C  
Relative humidity 10-85% non-condensing  
Shock and vibration compatible with light industrial usage

<sup>1</sup> Due to mechanical parts, unit must not be powered on when the ambient temperature is less than 5°C

<sup>2</sup> 50°C operation is based on unit with no expansion cards fitted. If expansion cards are fitted then this upper limit will be reduced. Contact [PlasmaPC@bluechiptechnology.co.uk](mailto:PlasmaPC@bluechiptechnology.co.uk) for more details on your proposed configuration

Construction:                                      Painted zinc-plated sheet steel, welded and riveted construction

Dimensions:                                        425 x 337 x 44.5 mm, excluding the mounting brackets

Note that an additional 130mm will be required in front of the DVD for the disk to eject, and at least 60mm to allow easy access to the cable connectors

**Air vents must not be obstructed. A minimum gap of 25mm between side vents and any adjacent items is recommended. A minimum gap of 45mm above the top of the chassis is also required**

## **General Precautions**

Your Single Board Computer is susceptible to damage by electrostatic discharges. In order to avoid damage, you should work at an anti-static bench and observe normal anti-static precautions. Wear an anti-static wrist strap connected to an earth point *before* opening any packaging.

Where a wrist strap is not available, discharge any static charge you may have built-up by touching an earth point. Avoid any further movement that could build up another static charge. Touch an earth point from time to time to avoid further build-up, and remove the items from their anti-static bags only when required

## **PS/2 Devices**

It is important that PS/2 devices (mouse and keyboard) are not connected or disconnected with the unit powered on. Damage or data corruption may occur if this precaution is not observed.

## **Electro-Static Discharges**

If you are going to open up the unit, it is important to realise that the devices on the cards within this unit can be damaged by static electricity. Bear in mind that the damage caused by static electricity may vary from total destruction to partial damage, which may not be immediately obvious. This could have an effect on the product's reliability and warranty. Before opening the chassis, ensure that you take necessary static precautions. Ideally you should work at an anti-static bench and wear an approved wrist strap or if that is not possible, touch a suitable ground to discharge any static build up before touching the electronics. This should be repeated if the handling continues for any length of time.

If it is necessary to remove a board or electronic assembly, place it into an anti-static bag. This will prevent any static electricity build up damaging the board. Metallised bags are preferred. Do not use black anti-static bags for any item containing a battery because these tend to be conductive and will discharge the battery.

## **On-Board Battery**

The processor board is fitted with a Lithium battery. Great care should be taken with this type of battery. If the battery is mistreated in any way there is a very real possibility of fire, explosion, and personal harm. Under NO circumstances should it be short-circuited, exposed to temperatures in excess of 100 °C or burnt, immersed in water, recharged or disassembled.

Expired batteries remain hazardous and must be disposed of in a safe manner, according to local regulations.

Le panneau de processeur est équipé d'une batterie de lithium. Le grand soin devrait être pris avec ce type de batterie. Si la batterie est mistreated il y a de dans de toute façon un possibility très vrai du feu, d'explosion et de mal personnel. Dans au cunes circonstances il est sous peu circuité, exposé aux températures au dessus de 100 degrés de centigrade ou brûlé, immergé dans l'eau, rechargée ou dissassembled.

Les batteries expirées restent dazaedous et doivent être reejetées d'une façon sûre, selon des règlements locaux.

## **BIOS & CMOS Memory**

Please be aware that with personal computer products, it is possible to create configurations within the CMOS memory that make booting impossible. If this should happen, clear the CMOS settings; (see the description of the Jumper Settings for details).

## **Electromagnetic Compatibility**

This product meets the requirements of the European EMC Directive (89/336/EEC) and is eligible to bear the CE mark.

It has been assessed operating in a Blue Chip Technology Industrial PC. However, because the board can be installed in a variety of computers, certain conditions have to be applied to ensure that the compatibility is maintained. Subject to those conditions, it meets the requirements for an industrial environment (Class A product).

- The board must be installed in a computer system chassis that provides screening suitable for an industrial environment.
- Any recommendations made by the computer system manufacturer/supplier must be complied with regarding earthing and the installation of boards.
- Any metal back plate must be securely screwed to the chassis of the computer to ensure good metal-to-metal (i.e. earth) contact.
- Connector bodies must be securely connected to the enclosure.
- The external cabling to boards causes most EMC problems. It is imperative that any external cabling to the board is totally screened, and that the screen of the cable connects to the metal end bracket of the board or the enclosure and hence to earth. It is recommended that round, screened cables with a braided wire screen are used in preference to those with a foil screen and drain wire. Use metal connector shells that connect around the full circumference of the cable screen: they are far superior to those that earth the screen by a simple “pig-tail”.
- The keyboard and mouse will play an important part in the compatibility of the processor card since they are ports into the board. Similarly, they will affect the compatibility of the complete system. Fully compatible peripherals must be used otherwise the complete system could be degraded. They may radiate or behave as if keys/buttons are pressed when subject to interference. Under these circumstances it may be beneficial to add a ferrite clamp on the leads as close as possible to the connector. A suitable type is the Chomerics type H8FE-1004-AS.
- USB cables should be high quality screened types.
- Ensure that the screens of any external cables are bonded to a good RF earth at the remote end of the cable.

Failure to observe these recommendations may invalidate the EMC compliance.

## Quick Start

The following sections explain how to install your Vario E2 Computer.

First ensure that you are familiar with the contents of the section "Precautions". It contains important information to avoid damage to the board.

The unit may be used free-standing, but it is recommended that it be securely mounted to avoid accidental damage. The actual mounting details will vary depending upon the application.

There are four M3 tapped holes on each end of the chassis for mounting brackets, etc. Do not use screws longer than those supplied to mount the unit, otherwise internal damage may result. If alternative screws are used, please ensure that they do not enter the chassis by more than 5mm, otherwise internal damage may result.

Particular mounting arrangements exist for NEC plasma displays. Others will be available. If you need something other than these brackets, then contact [PlasmaPC@bluechiptechnology.co.uk](mailto:PlasmaPC@bluechiptechnology.co.uk) with details of the particular mounting arrangement you require to see if something suitable already exists.

If the unit is to be used free-standing fit the adhesive synthetic rubber feet to the base. These will prevent the unit slipping on a smooth surface.

Connect the display to the VGA connector, and connect any other signals, e.g. LAN. Connect a PS/2 mouse and keyboard to the unit. Connect the power lead to a suitable AC power source. It is recommended that the supply be fused at 5A.

Press the 'Power On' button and check that the unit boots up.

If your system was not supplied with an operating system pre-installed, load an operating system and drivers. The section "Software Configuration" contains details for the common operating systems.

Set up the required video display parameters.

The system is now ready to have the applications software loaded.

If the mouse and keyboard are to be removed for normal operation, shut down the computer and switch off the power before removing them.

## Jumpers

The processor board used in the VARIO ELITE PC is largely free of selection jumpers. Most settings are controlled from the BIOS, and stored in the CMOS memory.

Only the following jumpers are significant.

### CMOS Clear

To clear the CMOS memory, first switch off the PC power, then locate the 3-pin header labelled 'CLRTC' on the processor board which is beside the battery connector. Remove the link shorting pins 1 and 2, and place it on pins 2 and 3 for about 5 - 10 seconds. Remove the link and replace it in its original position. The CMOS has now been cleared and the BIOS will be reset to the default settings.

Having no link fitted is an invalid option.

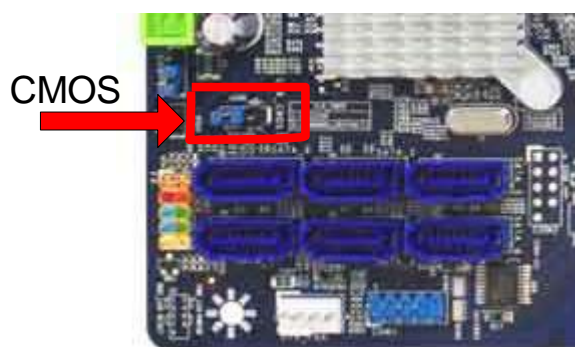

Figure 1: CMOS Jumper

## Front Panel Connector

The front panel connector is wired as follows

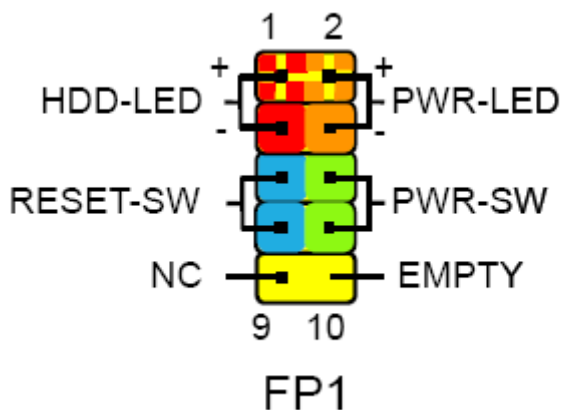

Figure 2: Front Panel

## External Connections

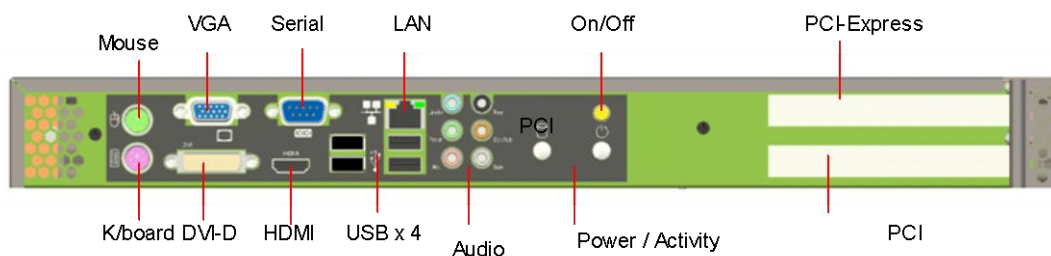

Figure 3: External Connections

### Audio

The Audio Ports can be configured as follows

Port	2-channel	4-channel	5.1-channel	7.1-channel
Blue	Line In	Line In	Line In	Line In
Green	Line Out	Front Speaker Out	Front Speaker Out	Front Speaker Out
Pink	Microphone In	Microphone In	Microphone In	Microphone In
Orange	-	-	Center/Subwoofer Out	Center/Subwoofer Out
Black	-	Rear Speaker Out	Rear Speaker Out	Rear Speaker Out
Grey	-	-	-	Side Speaker Out

## Upgrading Hardware

### Warning

Before attempting any upgrade to the VARIO E2 computer, please read the section "**Precautions**".

For your personal safety it is important that you ensure that the unit is switched off, and the AC supply is disconnected. Remember that the unit incorporates an ATX-type of power supply unit. Switching the power off using the front panel switch does not isolate the AC supply, and under these conditions the +5V DC standby power is still connected to the motherboard.

For the safety of the equipment, it is important that you observe electrostatic discharge precautions. Do not remove items from anti-static bags until necessary.

When making any internal changes to the computer, it is imperative that the internal cables follow the original routes and additional cables are installed as described. Failure to observe this requirement could restrict the airflow through the unit and cause overheating problems.

### Upgrade Options

The user may upgrade the unit by adding more memory or a faster CPU to the unit. Before upgrading, please check with Blue Chip Technical support to find out if your proposed upgrade is supported.

The addition of removable-media drives is normally a build option, because it requires the appropriate upgrade kit, and requires a measure of disassembly.

With the Vario E2, there is also the possibility of supporting expansion cards. This support is configurable at time of order due to the requirement for a specific riser solution.

**Caution: Unauthorised upgrades may invalidate the warranty if they are not compatible or are not carried out correctly and with care.**

## Adding / Upgrading Memory

The Vario E2 can support a maximum of 4 240-pin DDR2 SDRAM DIMMs

The combination of DIMM modules are

	DIMM1	DIMM2	DIMM3	DIMM4
Single Channel	X			
	X		X	
			X	
Dual Channel	X	X		
			X	X
	X	X	X	X

Note that when using multiple DIMMs always use DIMMs with the same CAS latency. For optimum compatibility always use matched modules.

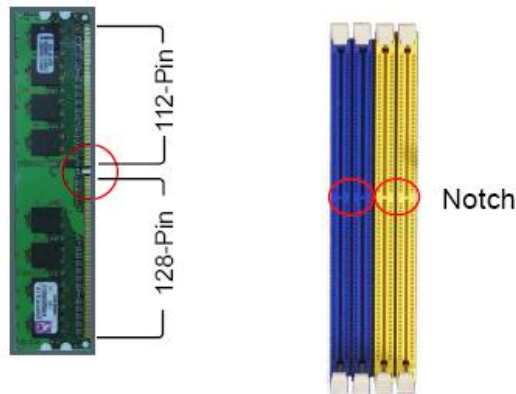

Figure 4: Memory Sockets

The DIMM module is removed by pulling back the retaining clip as shown in Figure 4. When inserting a DIMM align the notch correctly before pushing home. If pushed correctly, the retaining clip will lock the DIMM in place

## Upgrading/Changing the CPU

Insert the CPU in the orientation as shown in Picture 9. Unlock the socket by pressing the lever sideways and lifting up to a 90° – 100° angle. Carefully insert the processor, and then lower the lever, ensuring that it is locked closed

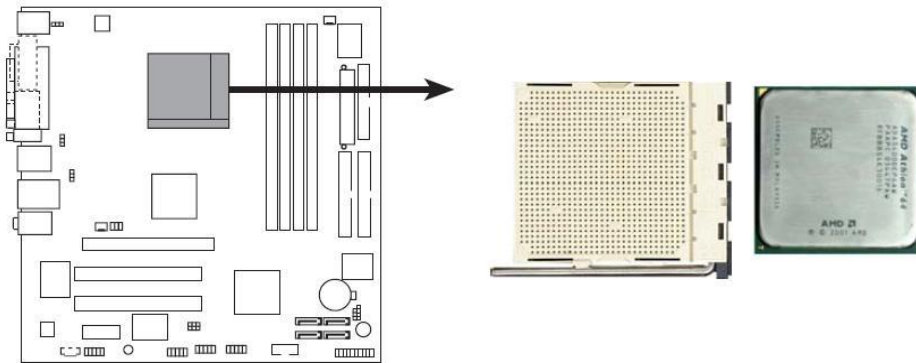

Figure 5: CPU Installation

Note: if the lever is not fully upright, then the pins on the CPU may get damaged during insertion

Once the CPU is installed, attach the heatsink. Place the heatsink onto the processor and line up the holes with the mounting plate before inserting the screws.

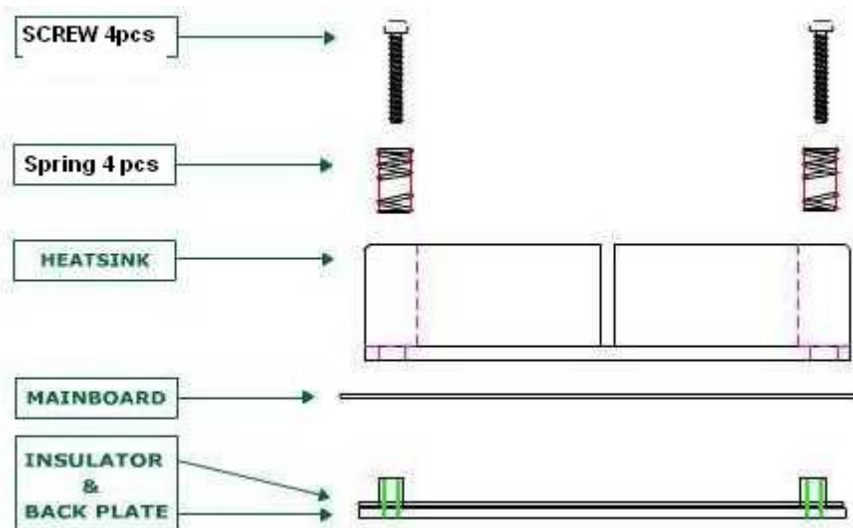

Figure 6: CPU Heatsink

**Changing a Chassis Fan**

If a chassis fan fails, then it should only be replaced with a fan of similar dimensions and specifications. Failure to do so may result in the system overheating and cause other components such as CPU and PSU to fail

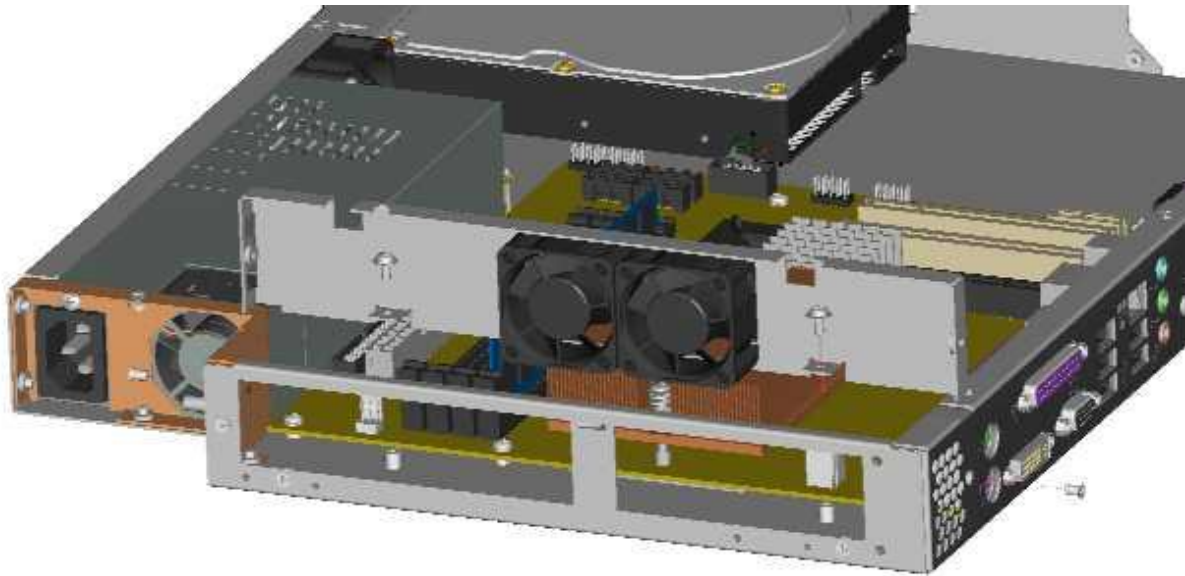

Figure 7: CPU Fan Assembly A

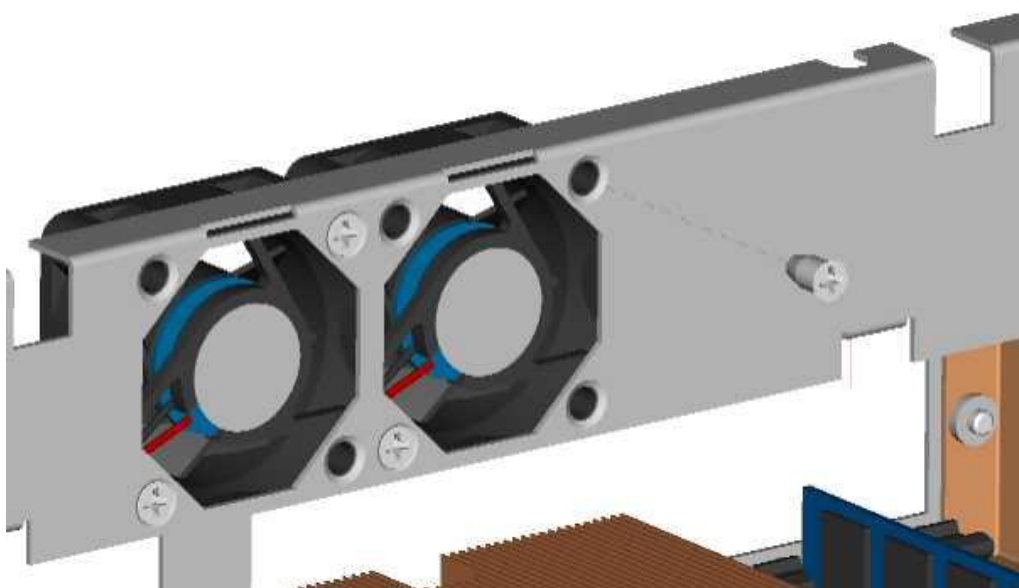

Figure 8: CPU Fan Assembly B

The 2 CPU fans are attached to a mounting plate as shown in Figures 7 and 8. To remove the assembly, there are four screws indicated which need to be removed beforehand. The assembly is then removed vertically from the chassis.

The fans themselves are attached to the mounting plate by two screws each. The two CPU fans are wired together, and both should be replaced at the same time if one fails.

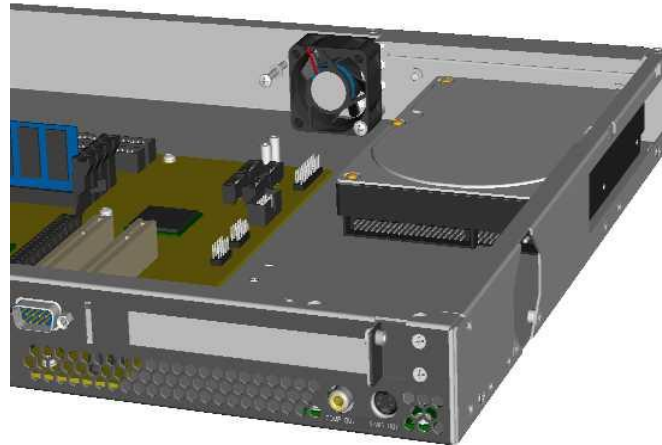

Figure 9: Chassis Fan Assembly

The system fan is located between the PSU and the HDD. The fan is held in place by two screws as shown in Figure 9. If difficulty is found trying to access the top screw, due to the PSU cable loom, then the PSU can be removed from the chassis beforehand.

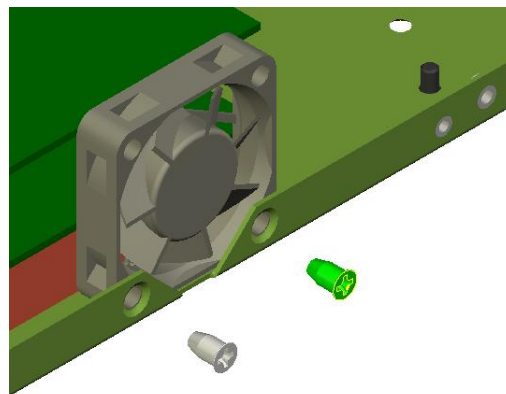

Figure 10: Expansion Fan Assembly

The optional Expansion fan is only fitted when either a PCI-Express or PCI card is also fitted. The fan is held in place by two screws shown in Figure 10 above.

## **Replacing the Optical Drive**

The Optical drive is a Factory fitted Option. It relies on two mounting brackets attached to the HDD. These brackets are not fitted as standard. The Optical drive is held in place by three screws shown below in Figure 11

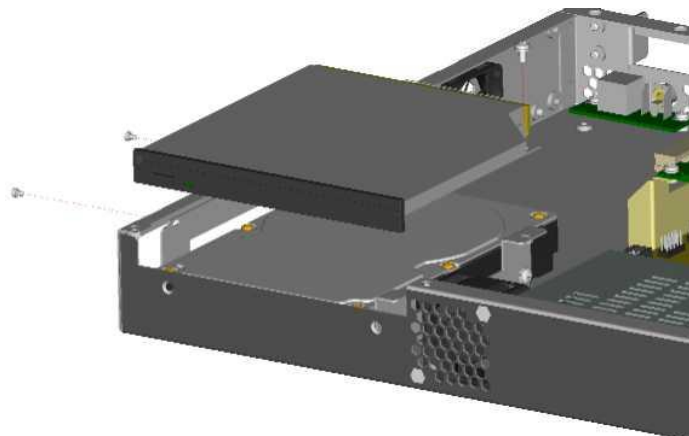

Figure 11: Optical Drive

## **Replacing the HDD**

The HDD is fitted directly to the base of the chassis by means of 4 screws shown in Figure 12

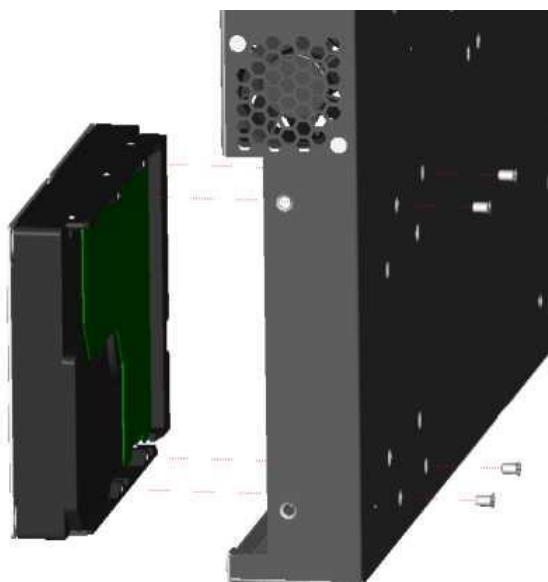

Figure 12: HDD

## **Replacing the On/Off Switch Assembly**

The On/Off Switch assembly is held in place by a single screw shown below

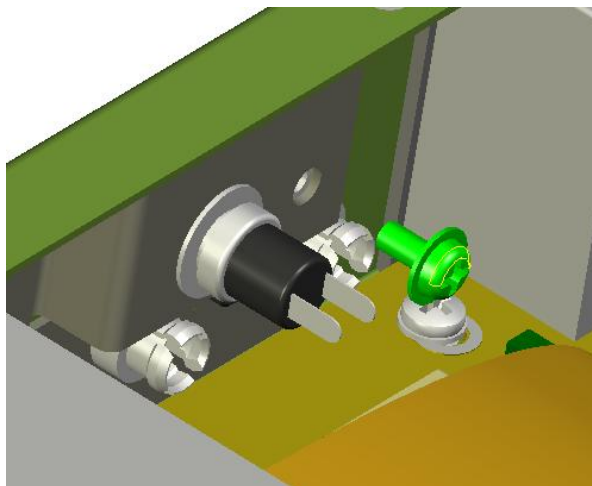

Figure 13: Switch Assembly

The switch is part of a cable loom which also contains two LEDs which plug into the front of the chassis below the switch. The Green LED is fitted directly below the power switch, and the Orange Drive Activity LED is fitted between the Green LED and the Audio Output connector.

## **Replacing/Fitting Optional Expansion Cards**

To add or remove an Expansion card, the Expansion fan must first be removed as shown in Figure 10

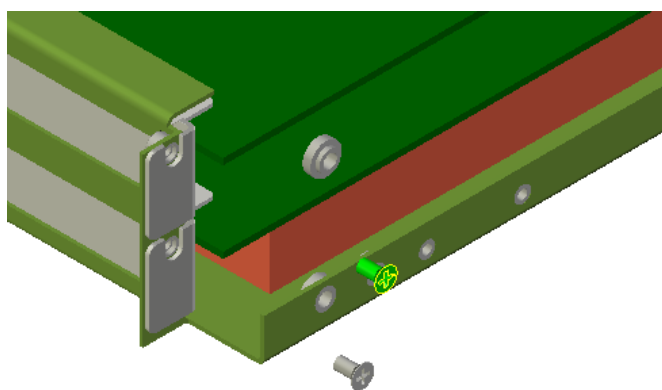

Figure 14: Expansion Cards

To remove the expansion card, first remove the screw retaining the I/O bracket as shown above, and then carefully pull the card away from the riser card assembly

## Removing the PSU

To remove the PSU it is first necessary to remove the PSU Bracket shown below

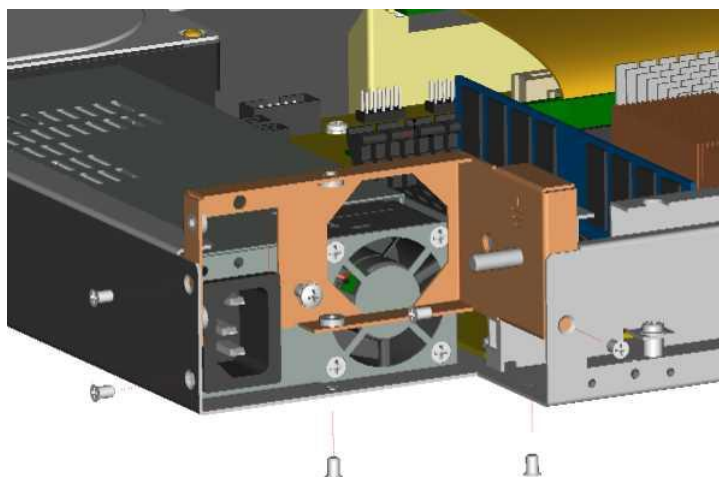

Figure 15: PSU Bracket

The bracket is held in place by 6 screws shown above. Once removed. The bracket is removed vertically from the chassis

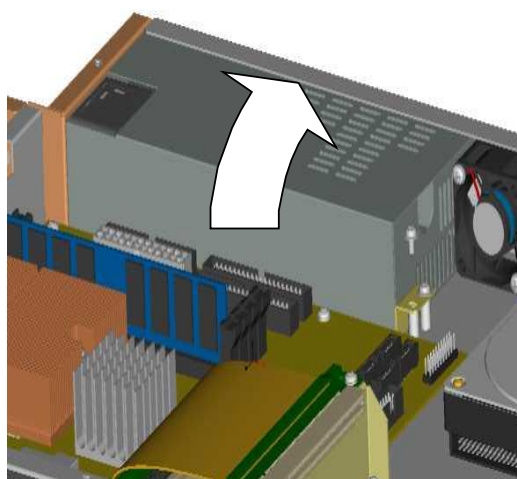

Figure 16: PSU removal

Lastly, the PSU is now only held in place by two screws attached to a small bracket at the rear of the PSU. Remove these two screws and the PSU can be removed by tilting in the direction of the arrow as shown in Picture

## **Installing Operating Systems**

Your VARIO E2 Small Form-Factor PC may have been supplied complete with a software operating system, in which case the appropriate drivers will have been loaded.

If it has been supplied without an operating system, one must be loaded following the instructions supplied with the software. It is then necessary to add driver programs for the specific hardware of the motherboard and any additional expansion cards. The manner in which the drivers are loaded will vary depending upon the actual operating system used. Details follow for Microsoft XP.

### **Microsoft XP**

To install the drivers for Windows XP, you can either follow the guided install from the Blue Chip Technology Support CD or manually install in order as follows.

#### **Chipset**

This update must be applied before installing any other drivers, and includes the graphics driver, and the HDMI Audio driver.

To install, go to the following directory on the Support CD

Drivers\Vario E2\1 chipset\

Run issetup.exe

#### **LAN**

The Video drivers are located on the Support CD at

Drivers\Vario E2\2 LAN\

Run Setup.exe and follow prompts

#### **Audio Drivers**

The Realtek Hi Definition Audio Drivers are located on the CD at

Drivers\Vario E2\HDAudio\

Run Setup.exe and follow instructions to install the Driver.

#### **Watchdog Utility**

The USB Watchdog is an additional item, and may be fitted on some units. The drivers for this can be found on the CD can be found at

\Drivers\Watchdog\

Prompt Device Manager to the INF file in this directory. Refer to Watchdog Documentation for further details.

## BIOS Setup

To enter the BIOS Setup pages, press <DEL> during Power-On-Self-Test (POST).

If you have made any changes to the BIOS Setup which you think may be causing you problems, then when you enter the BIOS Setup pages select LOAD Optimal Defaults to load the default BIOS settings.

If your BIOS needs to be updated for any reason, please check the Blue Chip Technology Website [www.bluechiptechnology.co.uk](http://www.bluechiptechnology.co.uk) to see if there is a later BIOS, or alternatively contact Technical Support

## Main Menu

The main menu allows you to select from a list of setup functions together with two exit choices. Use the arrow keys to select a specific item and press <Enter> to go to the sub-menu. Each item in the main menu is explained below:

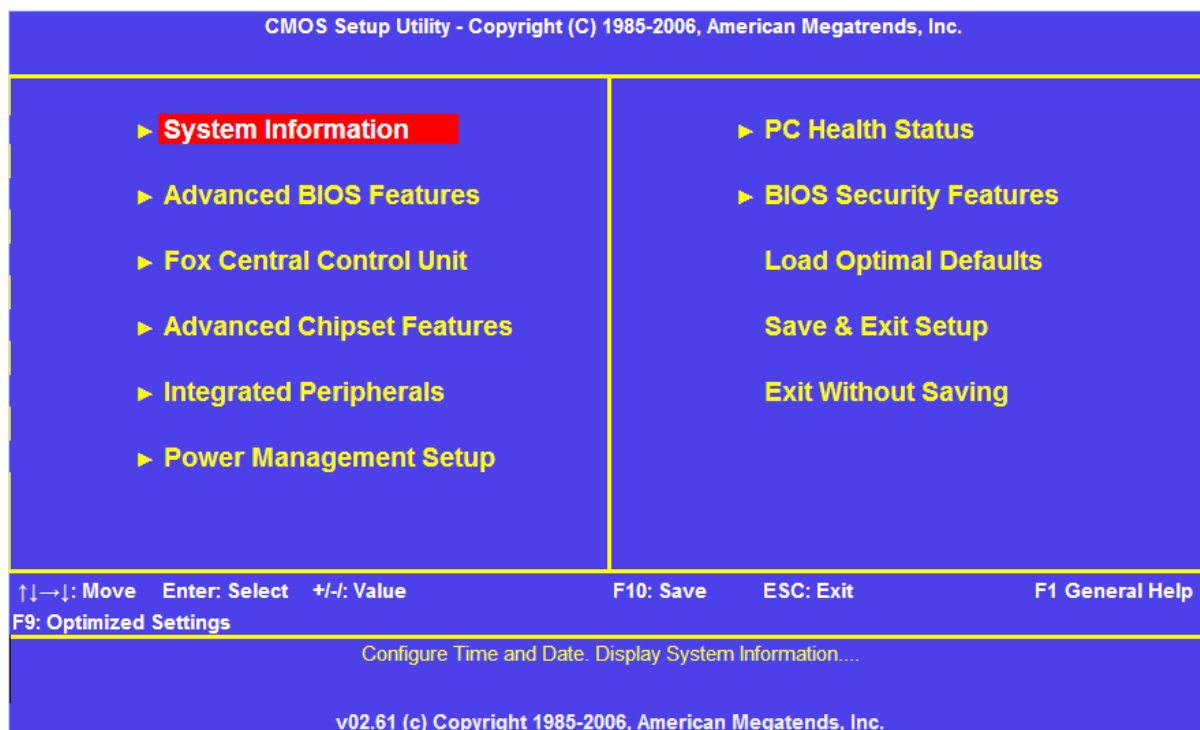

### System Information

This page displays the basic system configuration, such as BIOS ID, CPU Name, memory size plus system date, time and Floppy drive. They all can be viewed or set up through this menu.

### Advanced BIOS Features

The advanced system features can be set up through this menu, including boot up settings.

### Fox Central Control Unit

Some special proprietary features (such as overclocking) can be set up through this menu.

### Advanced Chipset Features

The values for the chipset can be changed through this menu, and the system performance can be optimized.

## **Integrated Peripherals**

All onboard peripherals can be set up through this menu. There are IDE devices, Super I/O devices such as Serial I/O and other USB devices... etc.

## **Power Management Setup**

All the items related with power saving function features can be set up through this menu.

## **PC Health Status**

This setup enables you to read/change Fan speeds, and displays temperatures and voltages of your CPU/System.

## **BIOS Security Features**

The Supervisor/User password can be set up through this menu to prevent unauthorized use of your computer. If you set a password, the system will ask you to key in correct password before boot or access to Setup.

## **Load Optimal Defaults**

The optimal performance settings can be loaded through this menu. However, although it may offer better performance in some ways (such as less I/O cards, less memory ...etc.), still, it may cause problem if you have more memory or I/O cards installed. If your system loading is heavy, set to optimal default may sometimes come out an unstable system. What you need now is to adjust BIOS setting one by one, trial and error, to find out the best setting for your actual configuration.

## **Save & Exit Setup**

Save setting values to CMOS and exit.

## **Exit Without Saving**

Do not change anything and exit the setup.



## Advanced BIOS Features

CMOS Setup Utility - Copyright (C) 1985-2006, American Megatrends, Inc.		
Advanced BIOS Features		
IDE Detect Time Out	[35]	Help Item Select the time out value for detecting ATA/ATAPI device(s) in second.
MPS Revision	[1.4]	
PCI Latency Timer	[64]	
Quiet Boot	[Enabled]	
Quick Boot	[Enabled]	
Bootup Num-Lock	[On]	
Floppy Drive Seek	[Disabled]	
▶ Boot Device Priority	[Press Enter]	
▶ Hard Disk Drives	[Press Enter]	
▶ Removable Drives	[Press Enter]	
▶ CD/DVD Drives	[Press Enter]	

↑↓→←: Move    Enter: Select    +/-: Value    F10: Save    ESC: Exit    F1 General Help  
F9: Optimized Settings

The important settings in this page are quick and quiet boot, as well as the Boot Order

When Enabled, Quiet Boot displays LOGO instead of POST Messages

When Enabled, Quick Boot allows BIOS to skip certain tests during POST

Fox Central Control Unit

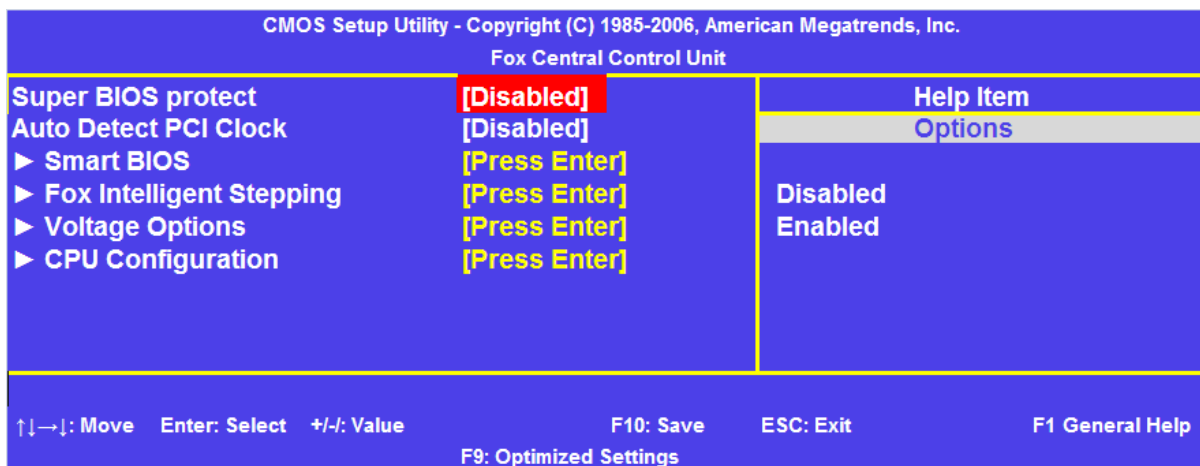

Under the Smart BIOS sub-menu, the Power On LED can be set to show different states during POST

System State	POWER LED Status
Normal	Always On
No Memory	Blinking: On (1sec) Off (1sec)
No Display	Blinking: On (2sec) Off (2sec)
Post Error Message	Blinking: On (1/3sec) Off (1/3sec) On (1sec)
No CPU Fan	Blinking: On (1/2sec) Off (1/2sec)

Under the CPU Configuration sub-menu, the Cool’N’Quiet when Enabled, allows the CPU frequency and voltage to be lowered when system is idling to help reduce the system power requirements and lower the CPU temperature

## Advanced Chipset Features

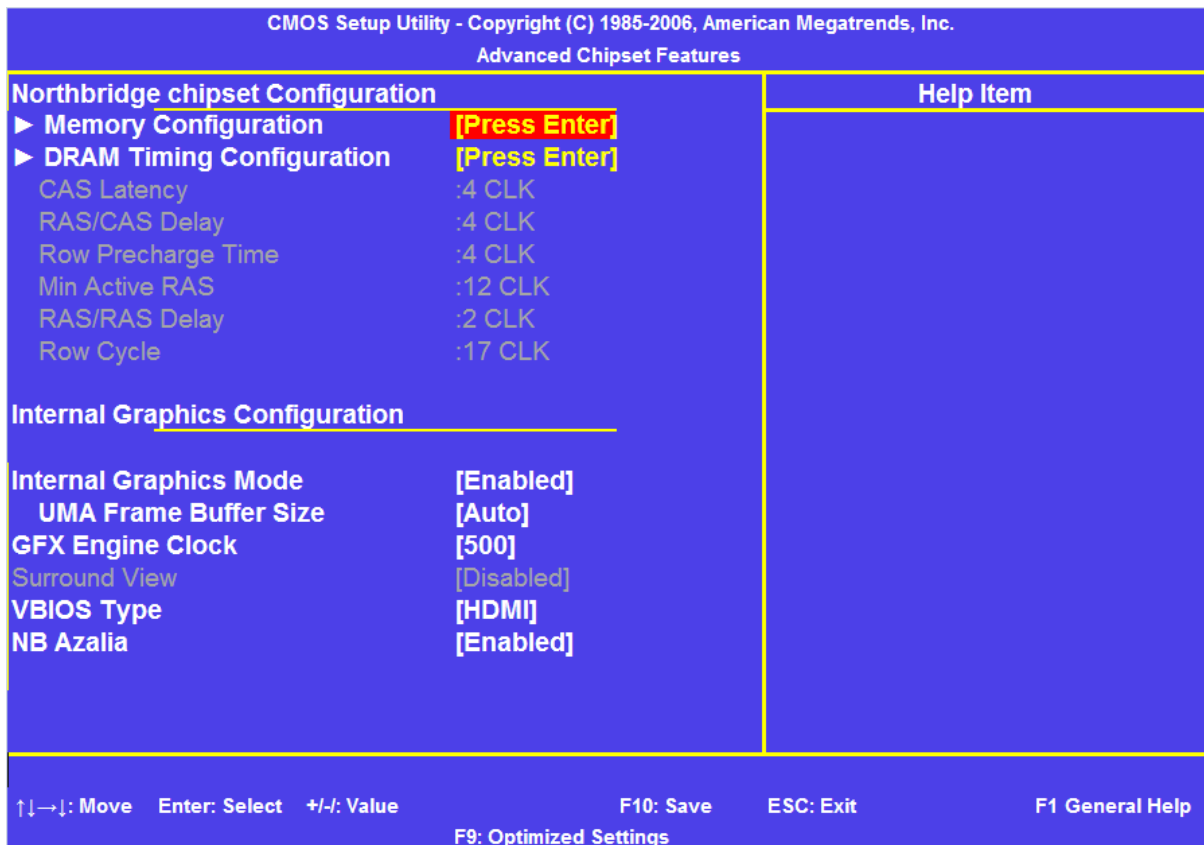

Important options here are

VBIOS Type setting, this offers the choice of HDMI or DVI video BIOS. Select the correct one to match your display type

When set to Enabled, the NB Azalia setting allows the HD Audio Controller within the Northbridge to be enabled for Audio output through the HDMI port

Integrated Peripherals

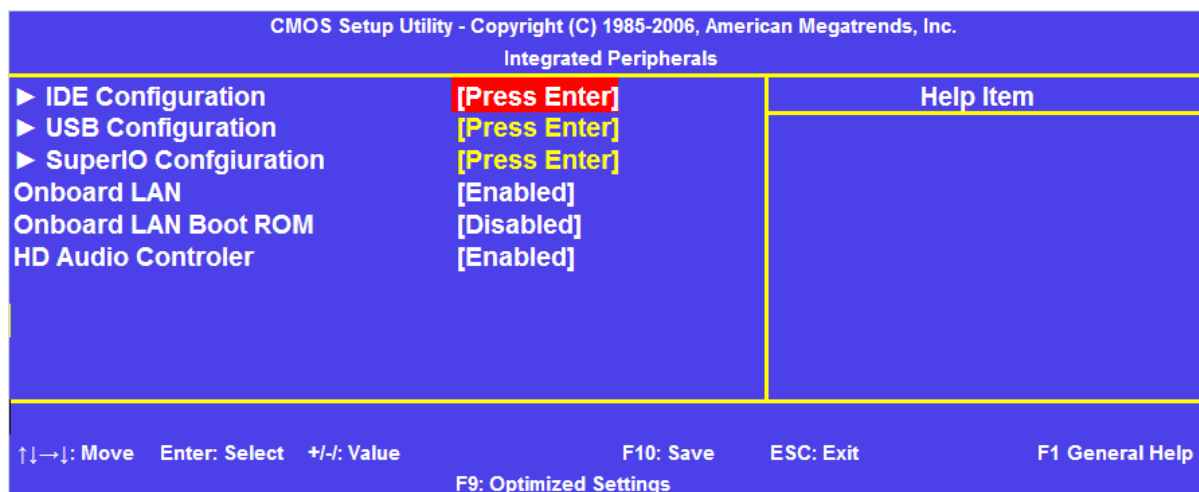

This Menu allows access to sub-menus to setup Drive options, control USB settings, Serial Port addressing and IR addressing

Power Management Setup

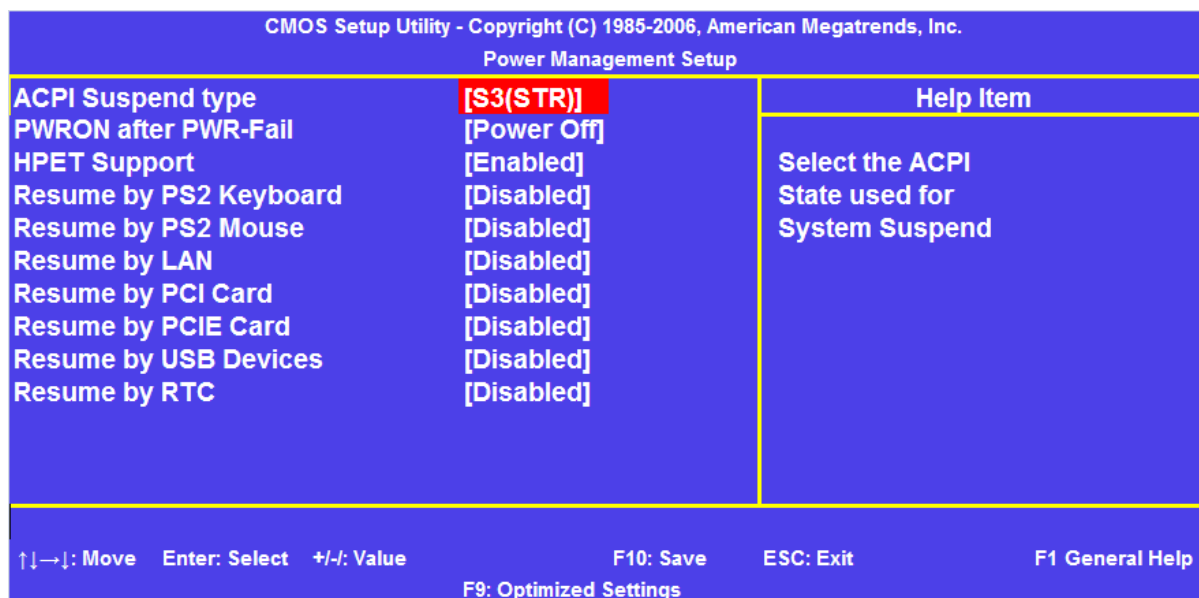

The important item on this page is the setting for how the BIOS should react after power has failed.

The options for PWRON after PWR-fail are Power On, Remain Off or Last State. When in Last State, if the Power loss occurs after the OS has been shutdown, then the system will remain off.

PC Health Status

CMOS Setup Utility - Copyright (C) 1985-2006, American Megatrends, Inc.		
PC Health Status		
		Help Item
Warning Temperature	[Disabled]	
Shut Down Temperature	[Disabled]	Options
Case Open Warning	[Disabled]	
CPU Temperature	:63 °C/145 °F	Disabled
System Temperature	:35 °C/95 °F	50 °C/122 °F
CPU Fan Speed	:N/A	55 °C/131 °F
System Fan Speed	:N/A	60 °C/140 °F
CPU Core	:1.232 V	65 °C/149 °F
DRAM Voltage	:1.888 V	70 °C/158 °F
NB Voltage	:1.088 V	75 °C/167 °F
+3.3V	:3.424 V	80 °C/176 °F
12.0V	:12.032 V	85 °C/185 °F
CPU Smart Fan Function	[Full On Mode]	90 °C/194 °F
System Smart Fan Function	[Full On Mode]	

↑↓→←: Move    Enter: Select    +/-: Value    F10: Save    ESC: Exit    F1 General Help  
F9: Optimized Settings

This menu displays temperature and voltage details which can be used to identify if the unit is operating out of specification.

The Warning Temperature can be set to provide warning information if the CPU temperature exceeds the set value.

The Shut Down temperature, in conjunction with an ACPI OS, can be used to automatically shut down the system if the CPU temperature is exceeded.

## BIOS Security Features

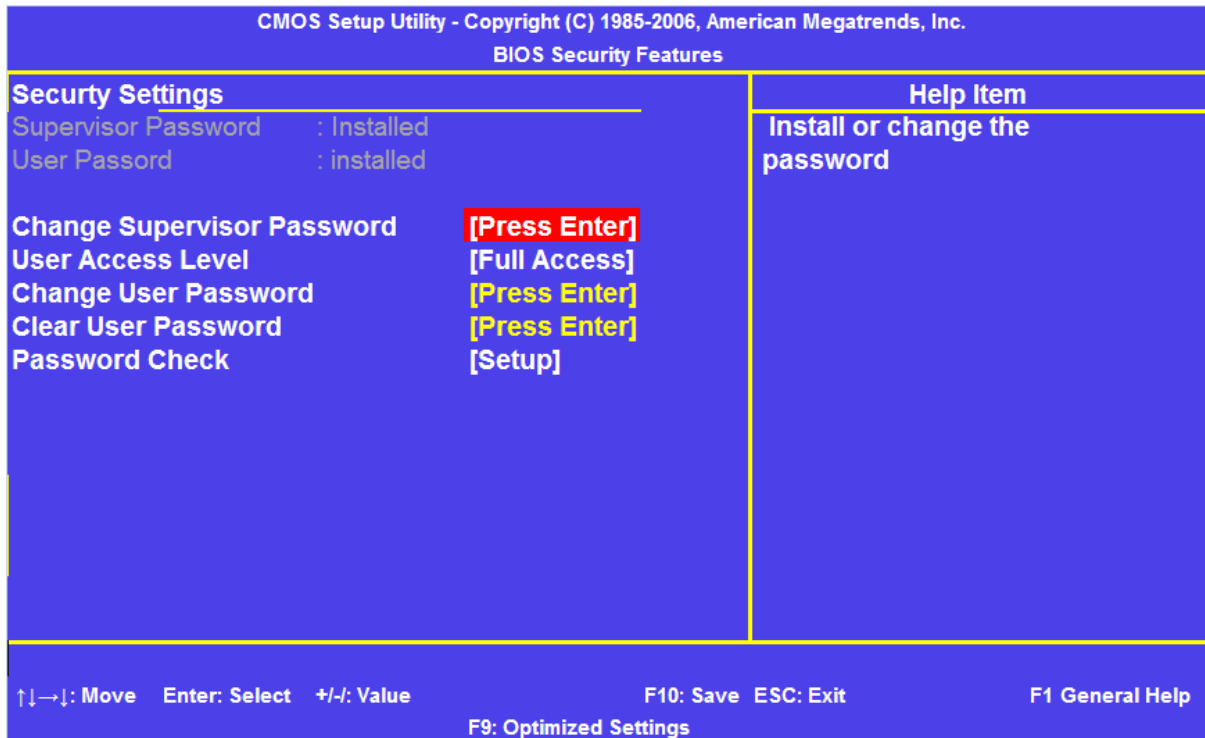

This menu allows Supervisor and User passwords to be set

## Maintenance

On a regular basis the inside of the VARIO ELITE unit should be cleaned out to prevent dust build up which could eventually clog the fans and prevent efficient operation. Generally the enclosure design and the wiring layout will ensure that the cooling is stable. However, bear in mind that any modifications to the installation may cause a restriction of the air vents.

After a period of several years, it may be necessary to replace the battery on the processor board, if it cannot maintain the CMOS memory whilst the AC power is disconnected.

### Replacing the Battery

The processor board includes a small 3V lithium battery (type CR-2032) to retain the BIOS settings in the CMOS memory. Before attempting to replace the battery, please read the precautions detailed in the introductory section. Remember that even discharged batteries can present a real personnel hazard if mistreated.

#### CAUTION

Danger of explosion if battery is incorrectly replaced.

Replace only with the same or equivalent type recommended by the manufacturer.

Dispose of used batteries according to the manufacturer's instruction.

#### ATTENTION

Il y a danger d'explosion s'il y a remplacement incorrect de la batterie.

Remplacer uniquement avec une batterie du même type ou d'un type recommandé par le constructeur.

Mettre au rebut les batteries usagées conformément aux instructions du fabricant.

Do NOT under any circumstances try to remove the battery with metallic tools (pliers, tweezers etc.). They will short out the battery with possible disastrous results.

Replace the battery by one of the same type, ensuring that it is fitted with the positive terminal facing the CPU, and that the clip is fully engaged. When the battery has been replaced, the BIOS settings will revert to their default settings. Reset them as necessary to suit your application.

### Fuses

There are no user-serviceable or replaceable fuses within the unit.

## Amendment History

Issue Level	Issue Date	Author	Amendment Details
1.0	29-05-2008	T Mck	First Release

## Contact Details

**Blue Chip Technology Ltd.**

**Chowley Oak**

**Tattenhall**

**Chester**

**CH3 9EX**

**U.K.**

**Telephone: +44 (0)1829 772000**

**Facsimile: +44 (0)1829 772001**

[www.bluechiptechnology.co.uk](http://www.bluechiptechnology.co.uk)

*Plasma PC Sales*

[PlasmaPC@bluechiptechnology.co.uk](mailto:PlasmaPC@bluechiptechnology.co.uk)

*Single Board Computer Sales*

[singleboardcomputer@bluechiptechnology.co.uk](mailto:singleboardcomputer@bluechiptechnology.co.uk)

*Rack mount PC Sales*

[rackmountpc@bluechiptechnology.co.uk](mailto:rackmountpc@bluechiptechnology.co.uk)

*Data and IO Sales*

[DataIO@bluechiptechnology.co.uk](mailto:DataIO@bluechiptechnology.co.uk)

*Technical Support*

[Support@bluechiptechnology.co.uk](mailto:Support@bluechiptechnology.co.uk)