



Vario A1
Small Form-Factor PC
User Guide

Document Reference: Product User Guide
Document Issue: 1.0

Contents

Copyright	3
Limitations of Liability	3
Trademarks	3
Regulatory Statements	4
Safety Warning for North America	4
Manual Organisation	5
Introduction	6
Specification	7
General Precautions	9
PS/2 Devices	9
Electro-Static Discharges	9
On-Board Battery	9
BIOS & CMOS Memory	10
Electromagnetic Compatibility	10
Quick Start	11
External Connections	12
Internal Connections	12
Jumpers	13
CMOS Clear	13
2 nd Serial Port	13
Front Panel Connector	14
Upgrading Hardware	15
Warning	15
Upgrade Options	15
Outline Drawing	16
Adding / Removing Mounting Brackets	21
Rear Mounting Bracket	21
Side Mounting Brackets	22
Removing / Fitting the Cover	22
Replacing / Fitting the Disk on Module	23
Replacing the HDD	24
Replacing the On/Off Switch Assembly	25
Installing Operating Systems	26
Software Watchdog	27
BIOS Setup	28
Main Menu	28
CMOS Features	29
Advanced BIOS Features	30
Advanced Chipset Features	31
Integrated Peripherals	32
Power Management Setup	34
PnP/PCI Configurations	35
PC Health Status	35
Maintenance	36
Replacing the Battery	36
Fuses	36
Amendment History	37

Copyright

All rights reserved. No part of this publication may be reproduced, stored in any retrieval system, or transmitted, in any form or by any means, electronic, mechanical, photocopied, recorded or otherwise, without the prior permission, in writing, from the publisher. For permission in the UK please contact Blue Chip Technology.

Information offered in this manual is believed to be correct at the time of printing. Blue Chip Technology accepts no responsibility for any inaccuracies. The information contained herein is subject to change without notice. There are no express or implied licences granted herein to any intellectual property rights of Blue Chip Technology Ltd.

Limitations of Liability

In no event shall Blue Chip Technology be held liable for any loss, expenses or damages of any kind whatsoever, whether direct, indirect, incidental or consequential, arising from the design or use of this product or the support materials supplied with this product. If this product proves to be defective, Blue Chip Technology is only obliged to replace or refund the purchase price at Blue Chip Technology's discretion according to their Terms and Conditions of Sale.

Trademarks

All trademarks and registered names acknowledged.

IBM, PC, AT and PS/2 are trademarks of International Business Machines Corporation (IBM).

Intel is a registered trademark of Intel Corporation.

All Intel processors are registered trademarks of Intel Corporation.

MSDOS and WINDOWS are registered trademarks of the Microsoft Corporation.

Regulatory Statements

CE

This product meets the essential protection requirements of the European EMC Directive (89/336/EEC) and its amending Directives, and the Low Voltage Directive 73/23/EEC, and is eligible to bear the CE mark.

Warning

This is a Class A product. In a domestic environment this product may cause radio interference in which case the user may be required to take adequate measures.

FCC

NOTE:

This equipment has been tested and found to comply with the limits for a Class A digital device, pursuant to Part 15 of the FCC Rules. These limits are designed to provide reasonable protection against harmful interference when the equipment is operated in a commercial environment. This equipment generates, uses, and can radiate radio frequency energy and if not installed and used in accordance with the instruction manual, may cause harmful interference to radio communications. Operation of this equipment in a residential area is likely to cause harmful interference in which case the user will be required to correct the interference at his own expense.

WARNING:

Changes or modifications not expressly approved by the manufacturer could void the user's authority to operate the equipment.

Safety Warning for North America

If the power lead (cord) is not supplied with the computer, select a power lead according to your local electrical regulations. In the USA use a 'UL listed' lead. In Canada use a CSA approved or 'cUL listed' lead.

Si le cordon secteur n'est pas livré avec l'ordinateur, utiliser un cordon secteur en accord avec votre code électrique nationale. En l'Etat Unis utiliser un cordon secteur 'UL listed'. En Canada utiliser un cordon secteur certifié CSA, ou 'cUL listed'.

Manual Organisation

This manual describes in detail the Vario A1 Small Form-Factor PC.

We have tried to include as much information as possible but we have not duplicated information that is provided in the standard IBM Technical References, unless it proved to be necessary to aid in the understanding of the product.

The manual is sectioned as follows:

- Introduction;
- Overview, listing the unit's features and specification;
- Installation, including what software to install
- Layout, showing where the various connectors are located, and their pin-out details;
- How to upgrade the system;
- Bios Setup
- Maintenance details

We strongly recommend that you study this manual carefully before attempting to interface with the Vario A1 or change the standard configurations. Whilst all the necessary information is available in this manual we would recommend that unless you are confident, you contact your supplier for guidance. ***IT IS PARTICULARLY IMPORTANT THAT YOU READ THE SECTION 'PRECAUTIONS' BEFORE HANDLING ANY COMPONENTS INSIDE THE UNIT.***

If you have any suggestions or find any errors concerning this manual and want to inform us of these, please contact our Technical Services department with the relevant details.

Introduction

The VARIO A1 is a powerful slim-line Intel ATOM based Personal Computer (PC) specifically designed to drive large plasma and other large displays panels. The unit is self-contained requiring as a minimum, only a power connection and a display. The applications are not limited to display applications: it may be used as a general purpose PC.

The basic unit comprises a highly integrated computer board employing the Intel N270 CPU, and Intel 945GSE and ICH7M chipset. Memory options allow up to 2GB of ultra fast 1066/800/667 MHz unbuffered ECC/ non-ECC DDR2 SDRAM. Storage is provided by either a Serial ATA II 3Gb/s hard disk drive or solid state storage. Solid state options include Disk on Module and 2.5" HDD.

The on-board GMA950 graphics supports Microsoft® DirectX 10.0, dual VGA out (RGB and DVI) and TV-Out.

The unit is housed in a strong sheet-steel enclosure providing both mechanical and EMC protection. The low power consumption allows for fan less design. The unit may be mounted on the plasma display, or separately to suit the particular installation. Mounting kits are available for specific plasma displays, wall or desktop.

Most connectors are on the front face of the chassis. There are connectors for a PS/2 mouse/keyboard, a standard analogue VGA display, a standard Digital Display, a TV-Out port, one serial port, three USB (2.0) ports, an Ethernet (10/100/1Gb) LAN port, and a Line-Out audio connector .

The DC power inlet connector is also on the front of the chassis, supporting a standard ID 2.5mm and OD 5.5mm short termination plug.

External indicators and controls on the front face of the chassis are limited to a hard drive activity LED, a power on LED and a power/standby push-button switch. The LAN connector also includes LEDs indicating a connection and data rate.

Specification

CPU:	Intel Atom N270
Chipset:	Intel 945GSE and ICH7M
Graphics Controller:	Integrated GMA950 RGB, DVI and TV-Out Maximum resolution of 2048x1536 for VGA output Picture rotation 0, 90, 180, 270 degrees
BIOS:	8Mb Flash EEPROM with LAN Boot, PnP, ACPI, DMI
Memory:	Dual Channel memory Architecture 1 x 200-pin SODIMM socket supporting up to 2GB of unbuffered non-ECC 1066/800/667 MHz DDR2 memory modules
LAN	Intel 82574L, supporting 10/100/1Gb rates
Audio:	Realtek ALC655
Expansion:	No Expansion available
Primary Storage:	One 3½” SATA II hard disk drive
Optional Storage:	One 2½” SATA Solid State HDD or One Disk On Module
External I/O:	Single PS/2 Connector. Keyboard and Mouse via splitter cable Standard VGA connector Digital DVI-D connector Composite TV-Out 9-way Serial connector (16550 compatible) RJ-45 10/100/1Gb Base-T Ethernet LAN connector Line Out 3 x USB 2.0 connectors
Indicators:	Power On LED, Hard Drive Activity LED
Control:	Power Standby push button switch
Watchdog:	Programmable timer, 1 second to 255 minutes
System Management:	CPU & System temperature monitoring Voltage monitoring of CPU Core, DRAM, NB, +3.3V, 12.0V
Power:	12V DC Internal Power External power via OD5.5mm, ID2.5mm short Jack Socket Typical Power Consumption: 22W based on 320Gb HDD, 1Gb RAM with XP professional running High CPU loading

Note: the plug should be no longer than 10mm long to avoid damaging the socket housing

Environmental Conditions: Operating temperature range +0°C ¹ to +40°C in free air
Storage temperature range -20°C to +70°C
Relative humidity 10-85% non-condensing
Shock and vibration compatible with light industrial usage

¹ Due to mechanical parts, if a hard drive is fitted, the unit must not be powered on when the ambient temperature is less than 5°C

Construction: Painted zinc-plated sheet steel, welded and riveted construction

Dimensions: 270 x 180 x 43 mm, excluding the mounting brackets

Air vents must not be obstructed. A minimum gap of 25mm between faces containing vents and any adjacent items is recommended.

General Precautions

Your Single Board Computer is susceptible to damage by electrostatic discharges. In order to avoid damage, you should work at an anti-static bench and observe normal anti-static precautions. Wear an anti-static wrist strap connected to an earth point *before* opening any packaging.

Where a wrist strap is not available, discharge any static charge you may have built-up by touching an earth point. Avoid any further movement that could build up another static charge. Touch an earth point from time to time to avoid further build-up, and remove the items from their anti-static bags only when required

PS/2 Devices

It is important that PS/2 devices (mouse and keyboard) are not connected or disconnected with the unit powered on. Damage or data corruption may occur if this precaution is not observed.

Electro-Static Discharges

If you are going to open up the unit, it is important to realise that the devices on the cards within this unit can be damaged by static electricity. Bear in mind that the damage caused by static electricity may vary from total destruction to partial damage, which may not be immediately obvious. This could have an effect on the product's reliability and warranty. Before opening the chassis, ensure that you take necessary static precautions. Ideally you should work at an anti-static bench and wear an approved wrist strap or if that is not possible, touch a suitable ground to discharge any static build up before touching the electronics. This should be repeated if the handling continues for any length of time.

If it is necessary to remove a board or electronic assembly, place it into an anti-static bag. This will prevent any static electricity build up damaging the board. Metallised bags are preferred. Do not use black anti-static bags for any item containing a battery because these tend to be conductive and will discharge the battery.

On-Board Battery

The processor board is fitted with a Lithium battery. Great care should be taken with this type of battery. If the battery is mistreated in any way there is a very real possibility of fire, explosion, and personal harm. Under NO circumstances should it be short-circuited, exposed to temperatures in excess of 100 °C or burnt, immersed in water, recharged or disassembled.

Expired batteries remain hazardous and must be disposed of in a safe manner, according to local regulations.

Le panneau de processeur est équipé d'une batterie de lithium. Le grand soin devrait être pris avec ce type de batterie. Si la batterie est mistreated il y a de dans de toute façon un possibility très vrai du feu, d'explosion et de mal personnel. Dans au cunes circonstances il est sous peu circuité, exposé aux températures au dessus de 100 degrés de centigrade ou brûlé, immergé dans l'eau, rechargée ou dissassembled.

Les batteries expirées restent dazaedous et doivent être reejetées d'une façon sûre, selon des règlements locaux.

BIOS & CMOS Memory

Please be aware that with personal computer products, it is possible to create configurations within the CMOS memory that make booting impossible. If this should happen, clear the CMOS settings; (see the description of the Jumper Settings for details).

Electromagnetic Compatibility

This product meets the requirements of the European EMC Directive (89/336/EEC) and is eligible to bear the CE mark.

It has been assessed operating in a Blue Chip Technology Industrial PC. However, because the board can be installed in a variety of computers, certain conditions have to be applied to ensure that the compatibility is maintained. Subject to those conditions, it meets the requirements for an industrial environment (Class A product).

- The board must be installed in a computer system chassis that provides screening suitable for an industrial environment.
- Any recommendations made by the computer system manufacturer/supplier must be complied with regarding earthing and the installation of boards.
- Any metal back plate must be securely screwed to the chassis of the computer to ensure good metal-to-metal (i.e. earth) contact.
- Connector bodies must be securely connected to the enclosure.
- The external cabling to boards causes most EMC problems. It is imperative that any external cabling to the board is totally screened, and that the screen of the cable connects to the metal end bracket of the board or the enclosure and hence to earth. It is recommended that round, screened cables with a braided wire screen are used in preference to those with a foil screen and drain wire. Use metal connector shells that connect around the full circumference of the cable screen: they are far superior to those that earth the screen by a simple "pig-tail".
- The keyboard and mouse will play an important part in the compatibility of the processor card since they are ports into the board. Similarly, they will affect the compatibility of the complete system. Fully compatible peripherals must be used otherwise the complete system could be degraded. They may radiate or behave as if keys/buttons are pressed when subject to interference. Under these circumstances it may be beneficial to add a ferrite clamp on the leads as close as possible to the connector. A suitable type is the Chomerics type H8FE-1004-AS.
- USB cables should be high quality screened types.
- Ensure that the screens of any external cables are bonded to a good RF earth at the remote end of the cable.

Failure to observe these recommendations may invalidate the EMC compliance.

Quick Start

The following sections explain how to install your Vario A1 Computer.

First ensure that you are familiar with the contents of the section "Precautions". It contains important information to avoid damage to the board.

The unit may be used free-standing, but it is recommended that it be securely mounted to avoid accidental damage. The actual mounting details will vary depending upon the application.

There are four M3 tapped holes on each end of the chassis for mounting brackets, etc. Do not use screws longer than those supplied to mount the unit, otherwise internal damage may result. If alternative screws are used, please ensure that they do not enter the chassis by more than 5mm, otherwise internal damage may result.

If you did not purchase mounting brackets but find that you actually need them, then contact PlasmaPC@bluechiptechnology.co.uk with details of the particular mounting arrangement you require to see if something suitable already exists.

If the unit is to be used free-standing fit the adhesive synthetic rubber feet to the base. These will prevent the unit slipping on a smooth surface.

Connect the display to the VGA connector, and connect any other signals, e.g. LAN. Connect a PS/2 mouse and keyboard to the unit. Connect the power lead to a suitable AC power source. It is recommended that the supply be fused at 5A.

Press the 'Power On' button and check that the unit boots up.

If your system was not supplied with an operating system pre-installed, load an operating system and drivers. The section "Software Configuration" contains details for the common operating systems.

Set up the required video display parameters.

The system is now ready to have the applications software loaded.

If PS/2 mouse and keyboard are to be used and removed for normal operation, shut down the computer and switch off the power before removing them.

External Connections

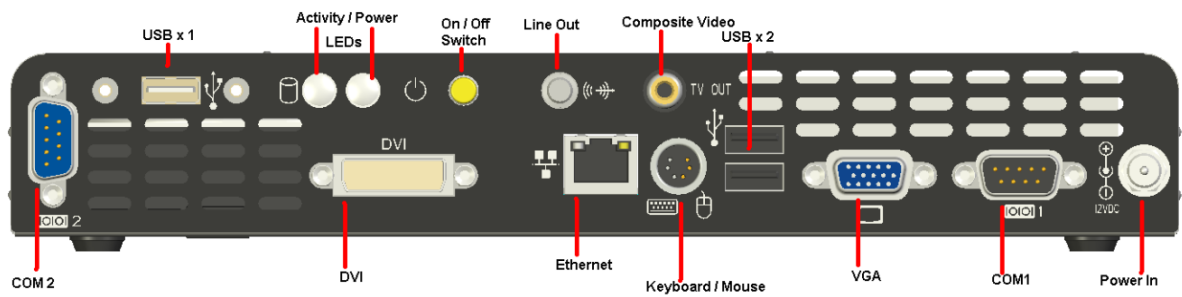

Figure 1: External Connections

Internal Connections

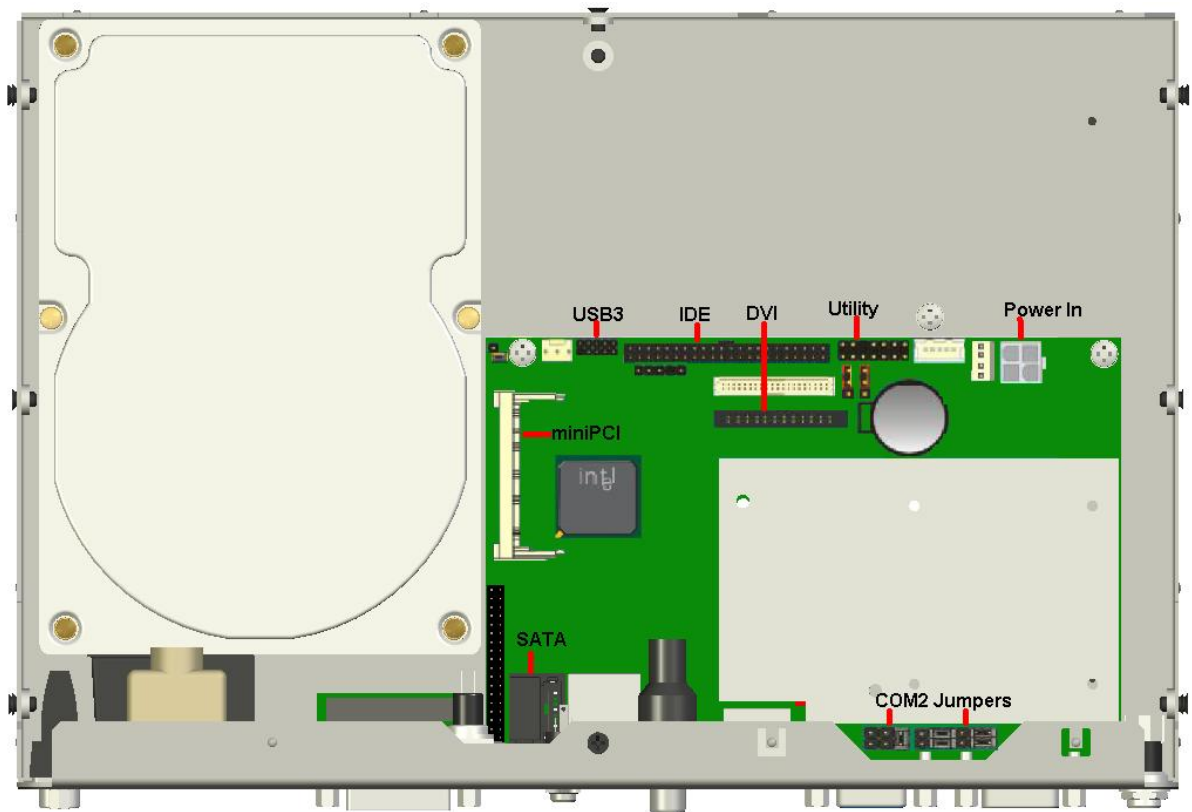

Figure 2: Internal Connectors

Jumpers

The processor board used in the VARIO A1 PC is largely free of selection jumpers. Most settings are controlled from the BIOS, and stored in the CMOS memory.

Only the following jumpers are significant.

CMOS Clear

To clear the CMOS memory, first switch off the PC power, then locate the 3-pin header labelled 'CLRTC' on the processor board which is beside the battery connector. Remove the link shorting pins 1 and 2, and place it on pins 2 and 3 for about 5 - 10 seconds. Remove the link and replace it in its original position. The CMOS has now been cleared and the BIOS will be reset to the default settings.

Having no link fitted is an invalid option.

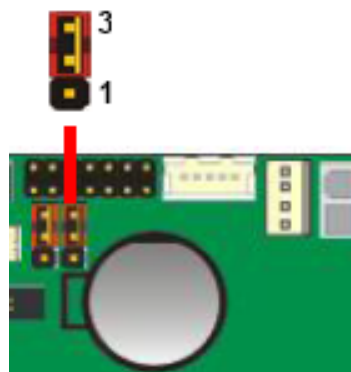

Figure 3: CMOS Jumper

2nd Serial Port

The second serial port can be configured as RS232, RS422 or RS485 via jumpers SP1 and SP2.

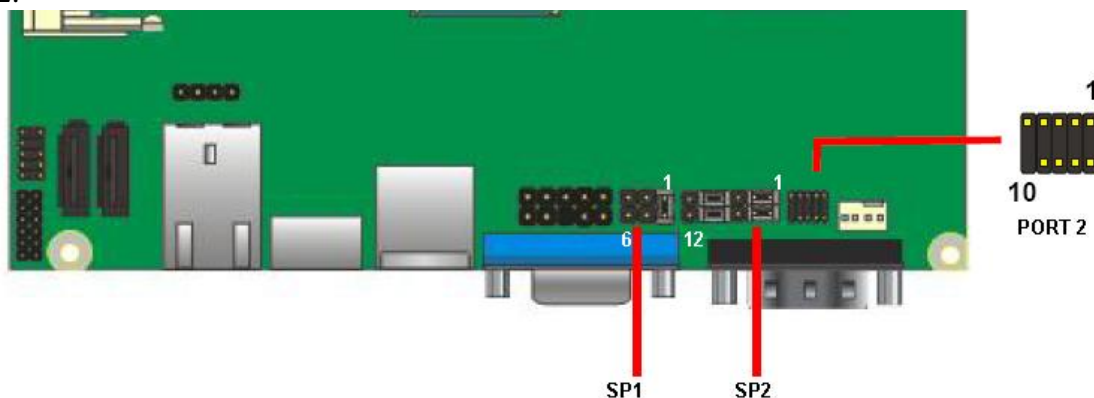

Figure 4: Serial Port 2

Access to the jumpers is via a cut out in the chassis when the top cover is removed

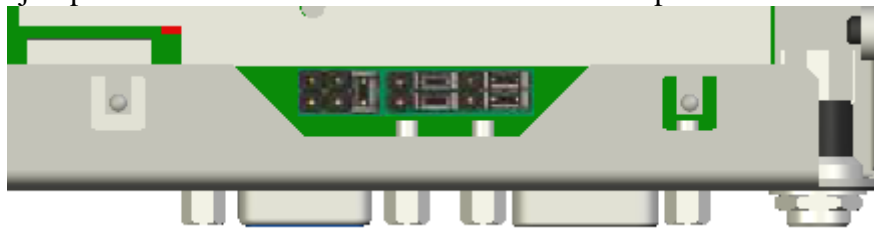

Figure 5: Jumper Access

SP1 and SP2 can be configured by connected the pins as follows

	SP1	SP2
RS232	Pins 1-2	Pins1-3 Pins 2-4 Pins 7-9 Pins 8-10
RS422	Pins 5-6	Pins3-5 Pins 4-6 Pins 9-11 Pins 10-12
RS485	Pins 3-4	Pins3-5 Pins 4-6 Pins 9-11 Pins 10-12

Front Panel Connector

The front panel connector is wired as follows

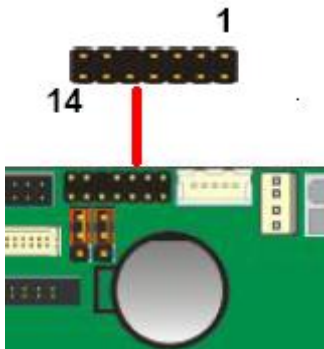

Pin	Signal	Pin	Signal
IDE LED		Power LED	
1	HDLED+	2	PWRLED+
3	HDLED-	4	n/c
Reset		6	PWRLED-
5	Reset+	Speaker	
7	Reset-	8	SPK+
9	n/c	10	n/c
Power Button		12	n/c
11	PWRBT+	14	SPK-
13	PWRBT-		

Figure 6: Front Panel

Upgrading Hardware

Warning

Before attempting any upgrade to the VARIO A1 computer, please read the section "**Precautions**". For your personal safety it is important that you ensure that the unit is switched off, and the DC supply is disconnected.

For the safety of the equipment, it is important that you observe electrostatic discharge precautions. Do not remove items from anti-static bags until necessary.

When making any internal changes to the computer, it is imperative that the internal cables follow the original routes and additional cables are installed as described. Failure to observe this requirement could restrict the airflow through the unit and cause overheating problems.

Upgrade Options

Due to the small footprint of the unit, there are minimal options to upgradeable. The Intel CPU is embedded onto the motherboard and there is only a single memory socket which is inaccessible to the user as it is on the underside of the motherboard.

Before attempting any upgrades, the user should check with Blue Chip Technical support to find out if your proposed upgrade is supported and if it will have any affect on the units' warranty
If a SATA Hard Drive is fitted, then possible upgrade is to fit a Disk on Module to increase storage. Similarly, if a Disk on Module is fitted then a SATA HDD could be fitted.

Caution: Unauthorised upgrades may invalidate the warranty if they are not compatible or are not carried out correctly and with care.

Outline Drawing

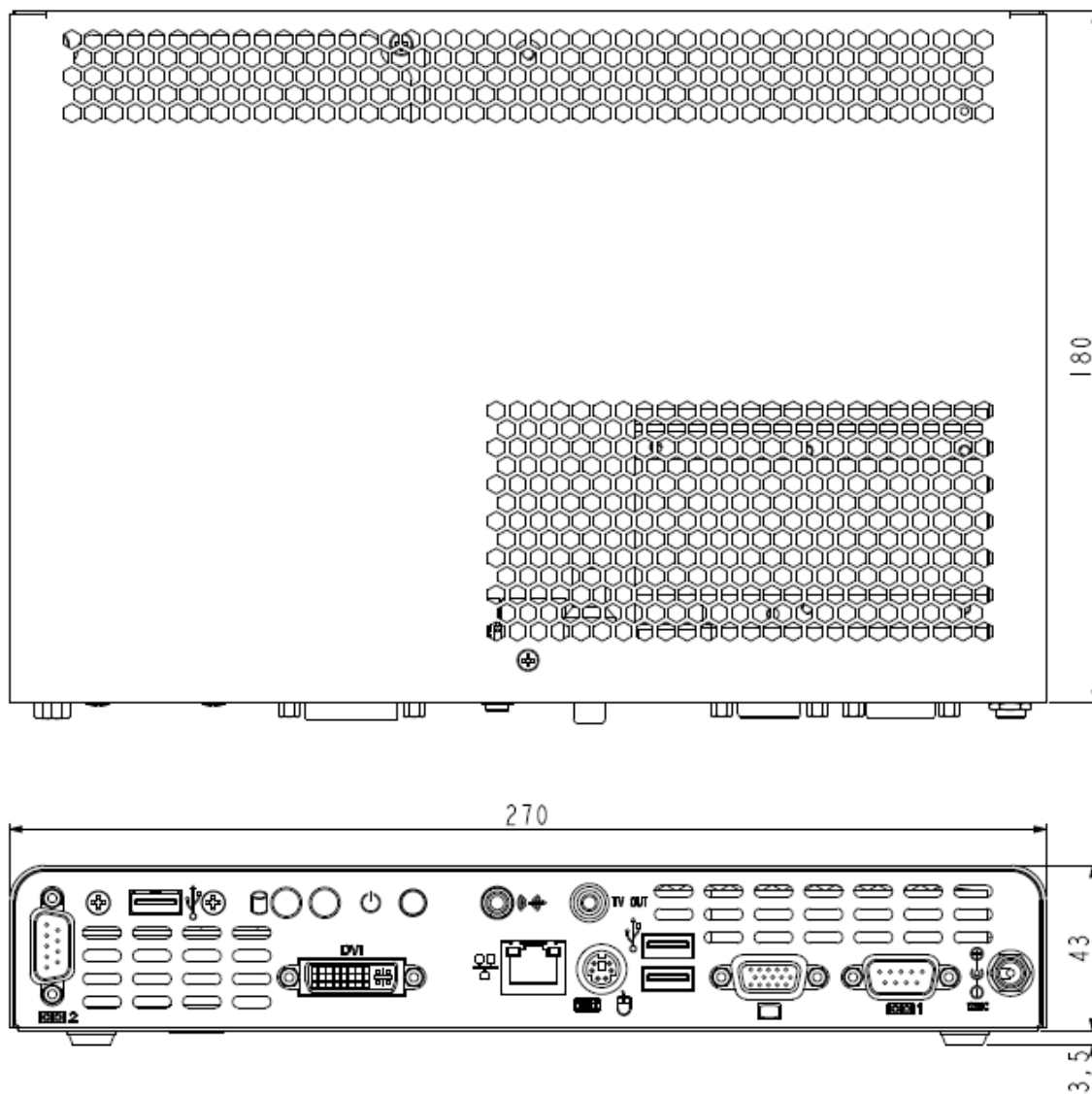

Figure 7: outline dimensions

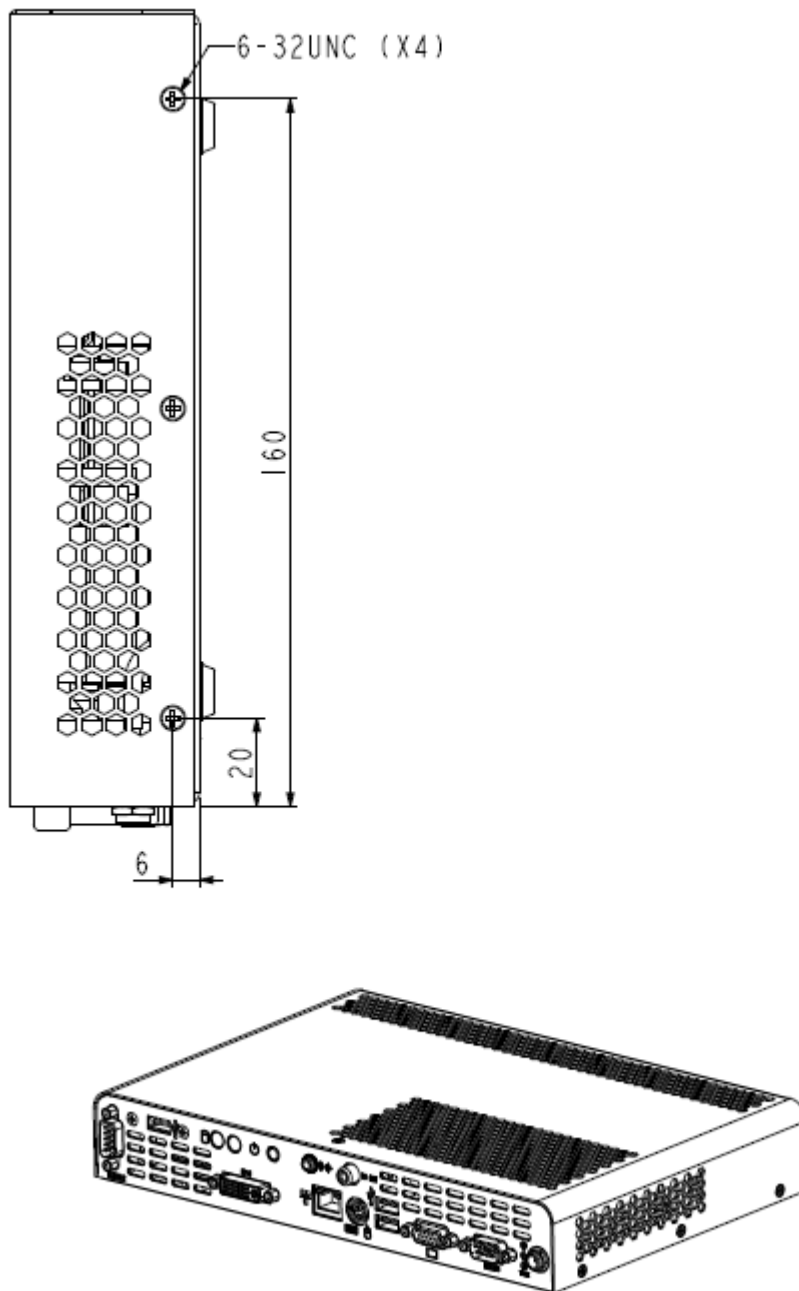

Figure 8: Mounting Screw locations

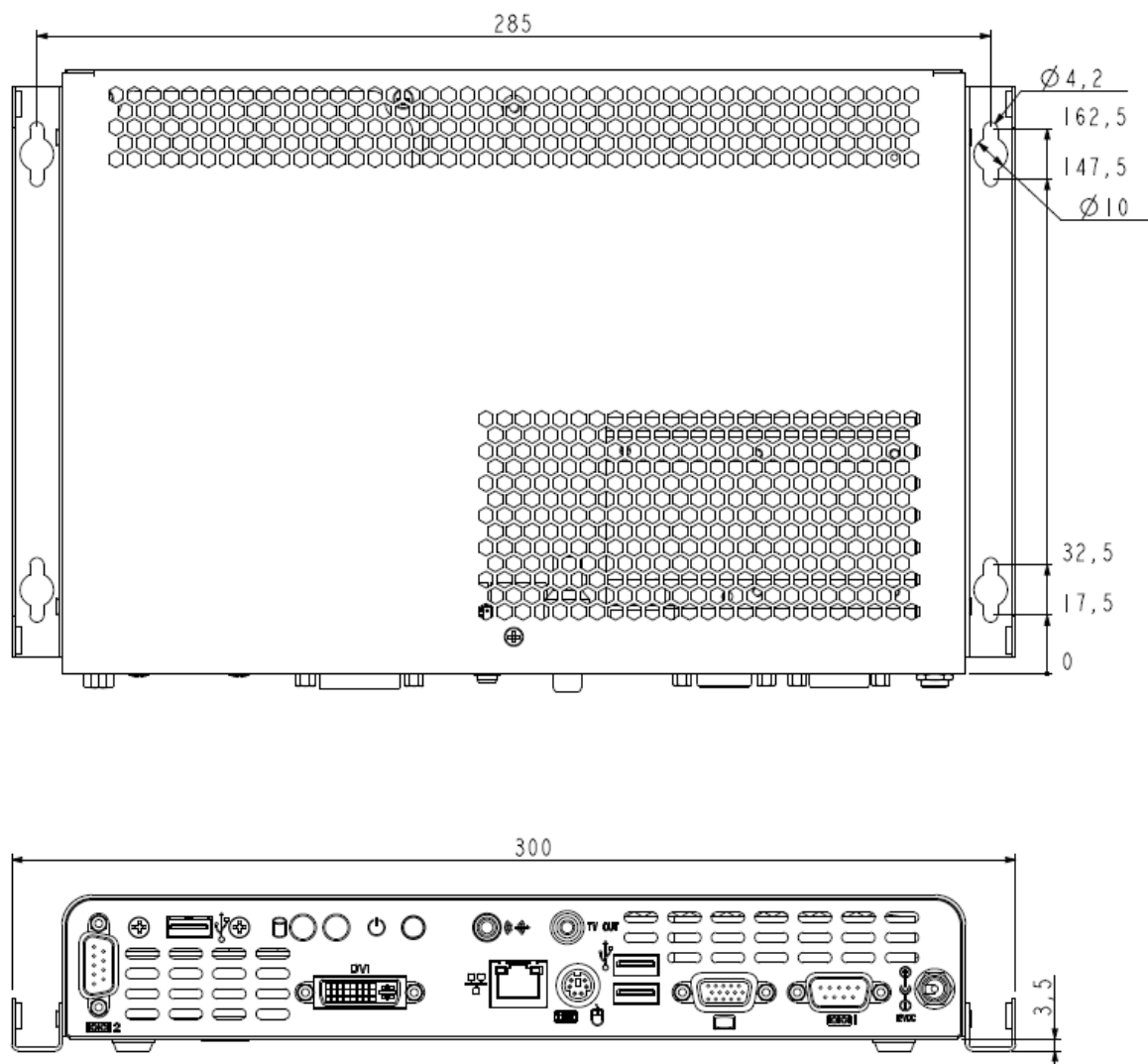

Figure 9: Side Mounting Bracket Dimensions

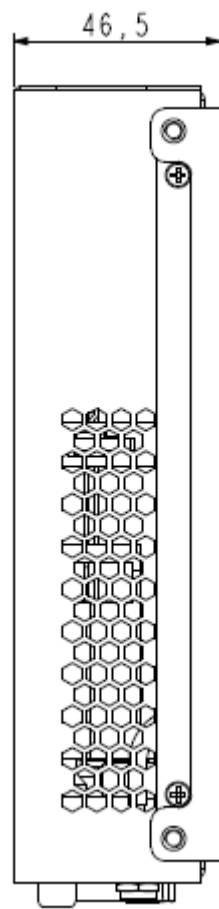

Figure 10: Side Bracket

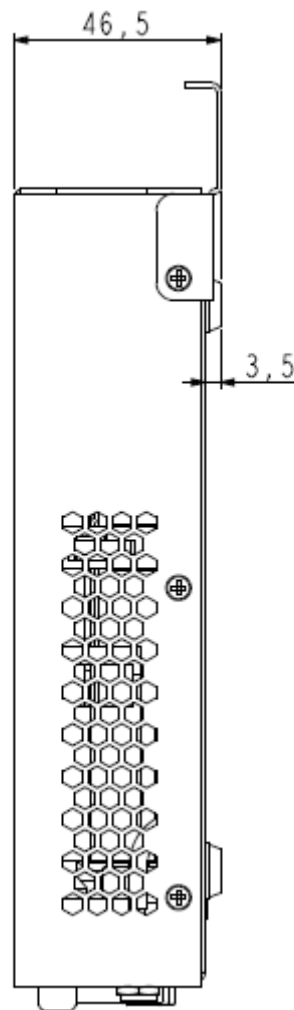

Figure 11: Back Bracket

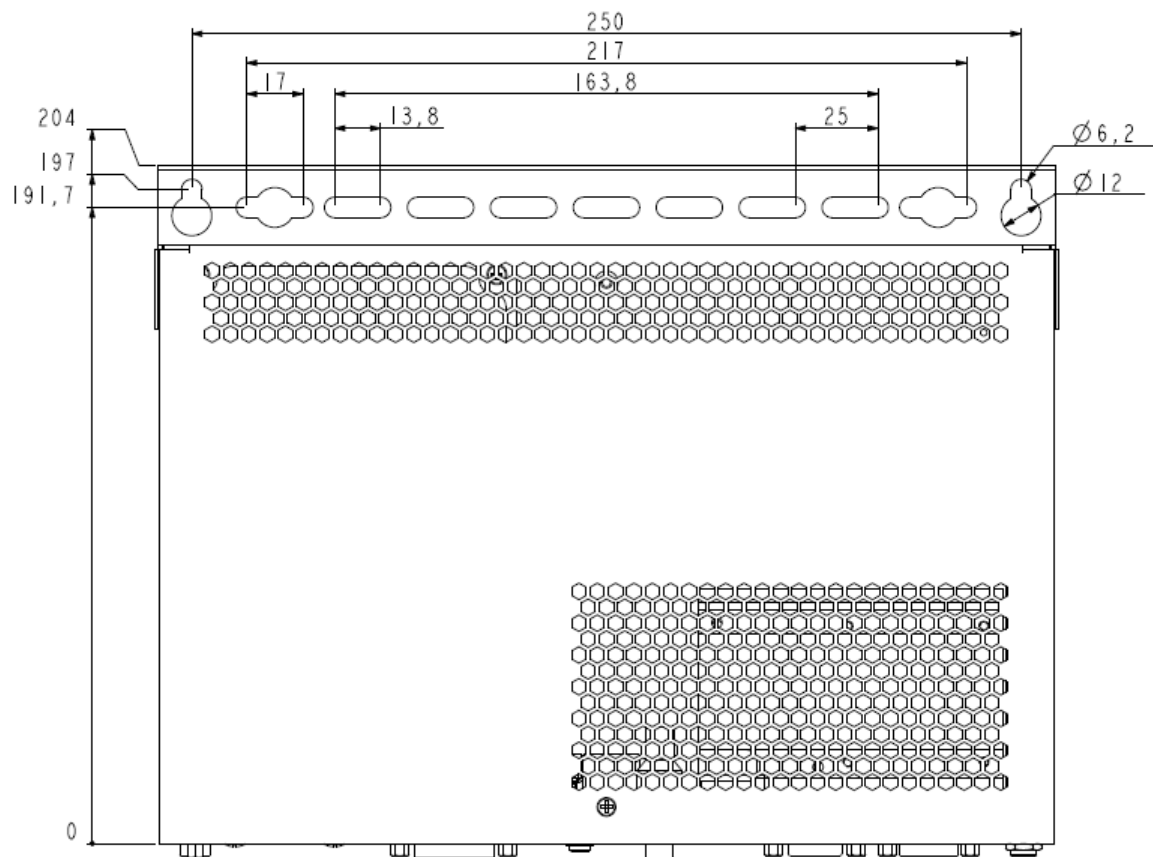

Figure 12: Rear Mounting bracket dimensions

Adding / Removing Mounting Brackets

There are three mounting bracket options for the Vario A1.

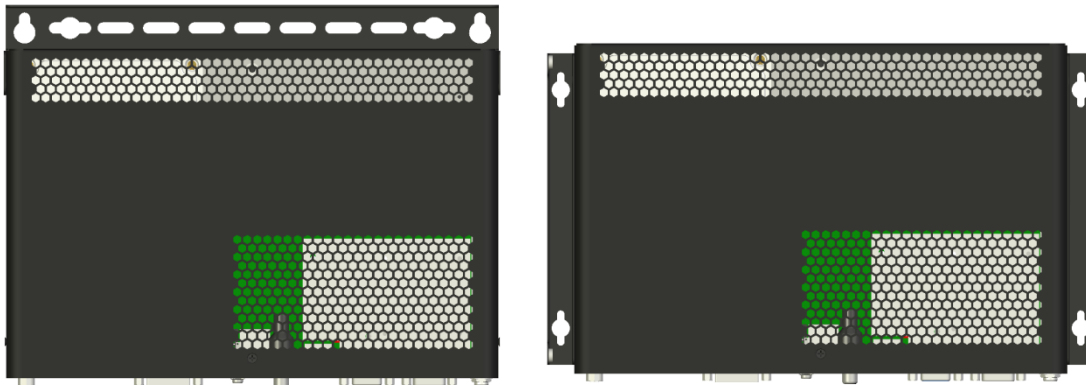

Figure 13: Single back mounting option (left), Double side mounting (Right)

Rear Mounting Bracket

The single back mounting bracket is attached to the Vario A1 by two screws which attach into the side of the unit and a single screw which attaches to the base as shown below

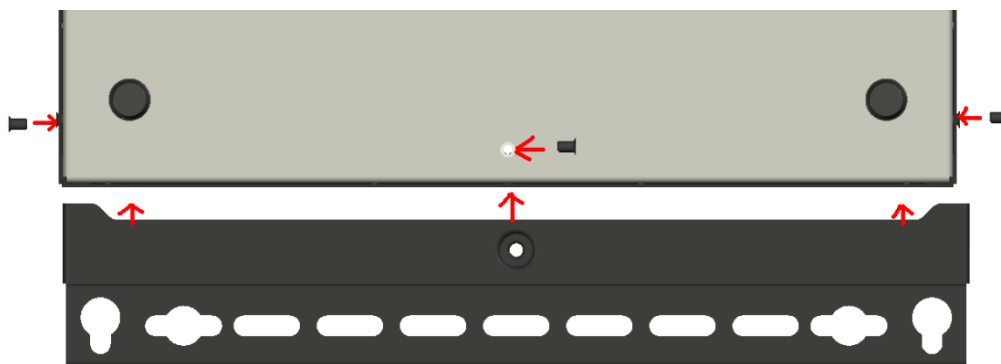

Figure 14: Top Bracket

Side Mounting Brackets

There are two side mounting brackets which attach to the unit as shown below

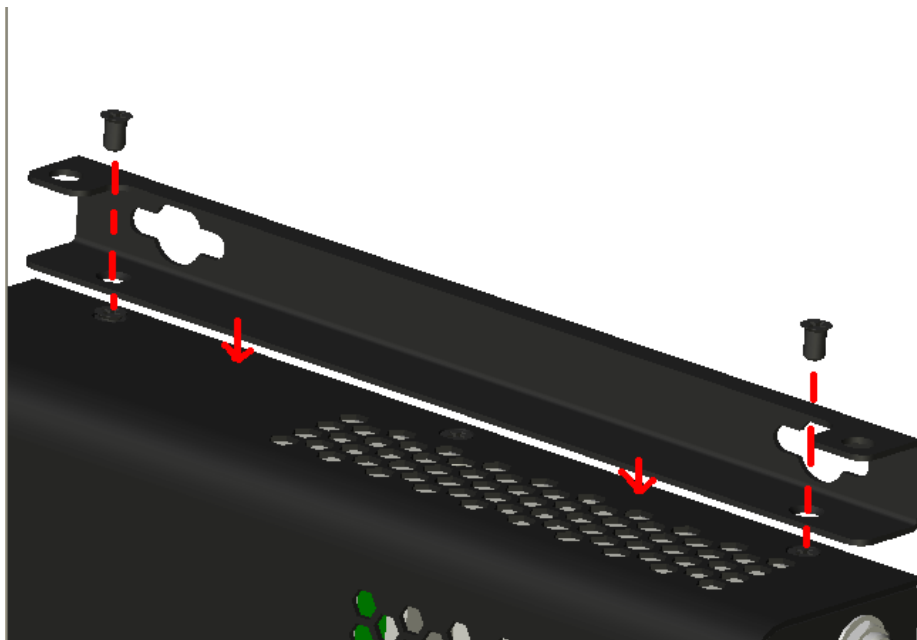

Figure 15: Side Bracket

Removing / Fitting the Cover

The cover is held in place by screws in the top and in both sides

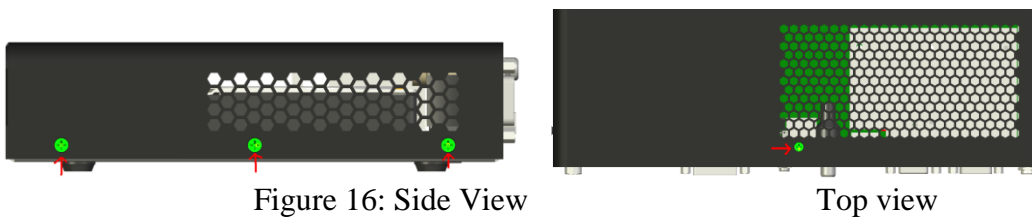

Figure 16: Side View

Top view



Figure 17: Cover slides on and off

Replacing / Fitting the Disk on Module

If fitted, the Disk On Module is fitted directly to the IDE connector shown below

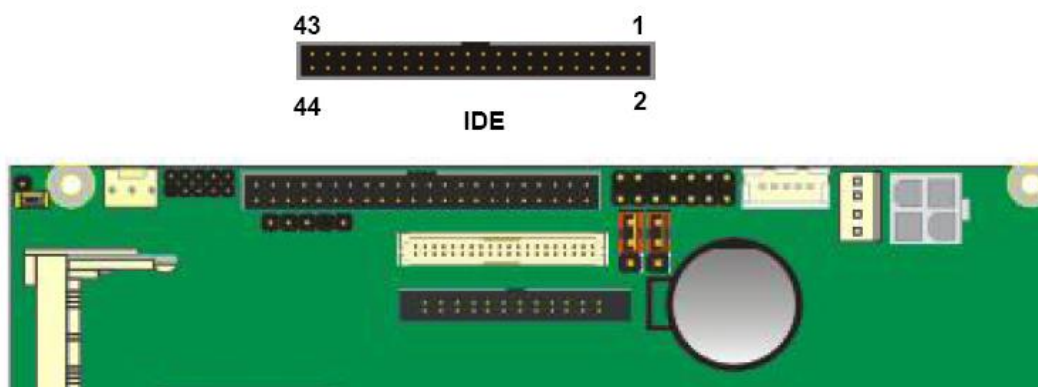

Figure 18: IDE Connector

Replacing the HDD

The HDD is fitted directly to the base of the chassis by means of 4 screws shown below

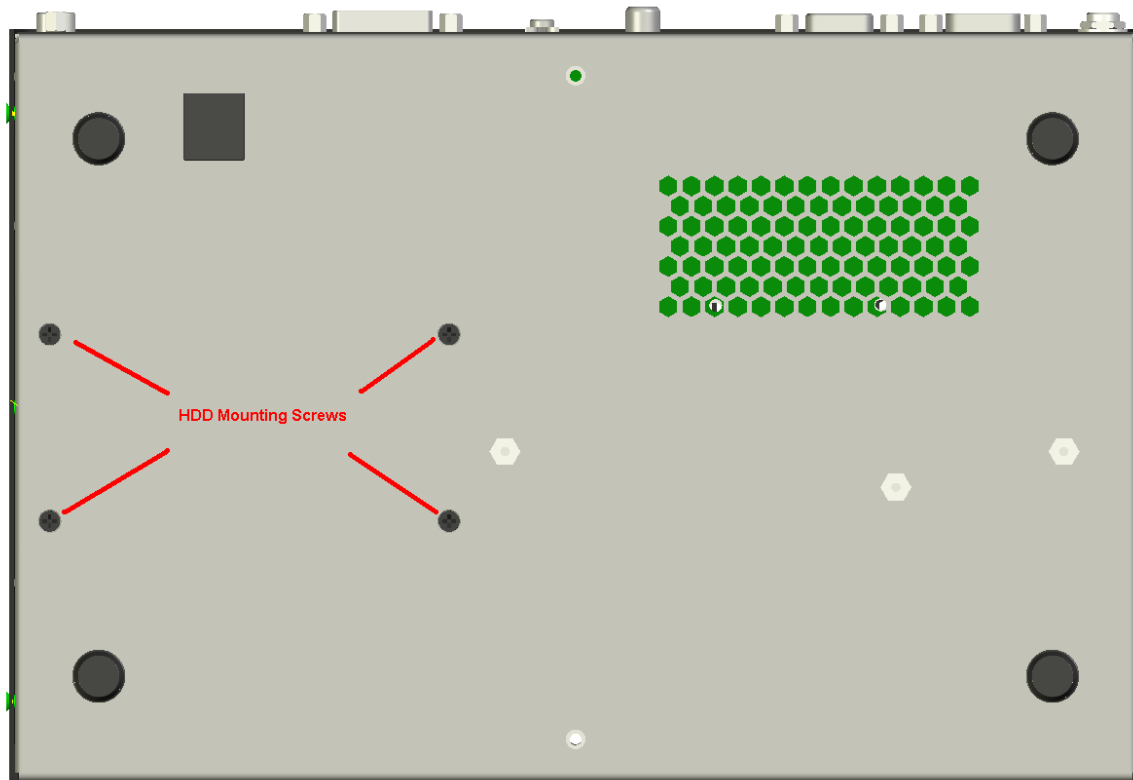

Figure 19: HDD

If a 2.5" Solid State device is fitted instead, then this will be mounted in a caddy which will also attach directly to the base using these screws.

Replacing the On/Off Switch Assembly

The On/Off Switch assembly is held in place by a single screw shown below

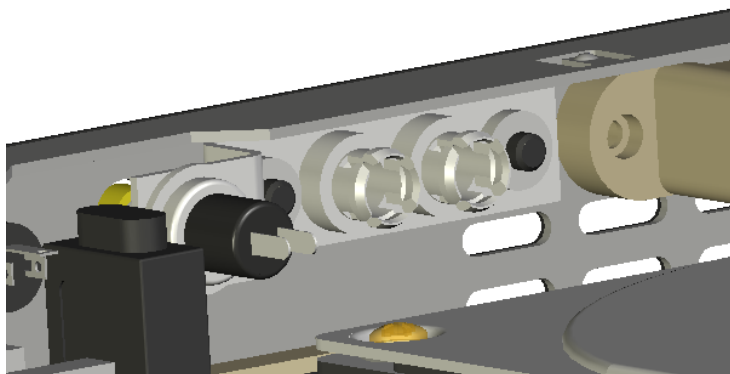

Figure 20: Switch Assembly

The switch is part of a utility cable loom which also contains two LEDs which plug into a bracket at the front of the chassis. The bracket is attached to the front of the chassis by means of two screws which can only be accessed when the front overlay is removed.

The Utility cable loom is plugged into the motherboard at the connector shown in [Figure 6](#)

Installing Operating Systems

Your VARIO A1 Small Form-Factor PC may have been supplied complete with a software operating system, in which case the appropriate drivers will have been loaded.

If it has been supplied without an operating system, one must be loaded following the instructions supplied with the software. It is then necessary to add driver programs for the specific hardware of the motherboard and any additional expansion cards. The manner in which the drivers are loaded will vary depending upon the actual operating system used. Details follow for Microsoft XP.

Microsoft XP

To install the drivers for Windows XP, you can either follow the guided install from the Blue Chip Technology Support CD or manually install in order as follows.

To install, go to the following directory on the Support CD
Drivers\Vario A1\

Chipset

This update must be applied before installing any other drivers
Run 1_infinst.exe

Video

Run 2_video.exe

LAN

Run 3_lan.exe

Audio Drivers

Run 4_audio.exe

Software Watchdog

The Vario A1 has a built in Watchdog Timer. The Watchdog Timer (WDT) is a special hardware device that monitors the computer system during normal operation. The WDT has a clock circuit that counts down from a set number to zero. If a monitored item occurs before that timer reaches zero, the WDT resets and counts down again. If for some reason the monitored item doesn't occur before the timer reaches zero, the WDT performs an action, such as a diagnostic operation (rebooting the computer) or generate an NMI. which can reset the computer in cases where the System hangs or it stops working.

The timer can be initiated in BIOS or by software when the system boots. To initiate the Timer in BIOS navigate to the [Integrated Peripherals](#) page

The Watchdog can be controlled by software program in the following manner

Watchdog Configuration		
Address Port: 2Eh	Data Port: 2Fh	Description
87h		Unlock WDT
87h		“
07h	08h	Select Logic Device
30h	01h	Activate WDT
F5h	N	Set Second or minute: N=00h (second) N=08h (minute)
F6h	M	Set base timer as below
Watchdog counts down		
F6h	M	Reset Timer
If Timer not reset, then WDT Timeout		
30	00	Disable WDT

M=	N=00h	M=08h
00h	Time out Disable	Time out Disable
01h	Time out occurs after 1 second	Time out occurs after 1 minute
02h	Time out occurs after 2 seconds	Time out occurs after 2 minutes
.....
FFh	Time out occurs after 255 seconds	Time out occurs after 255 minutes

Example (C):

The following example sets up the watchdog time to 5 minutes.

1. outportb(0x2e,0x87);
2. outportb(0x2e,0x87);
3. outportb(0x2e,0x07);
4. outportb(0x2f,0x08);
5. outportb(0x2e,0x30);
6. outportb(0x2f,0x01);
7. outportb(0x2e,0xF5);
8. outportb(0x2f,0x08);
9. outportb(0x2e,0xF6);
10. outportb(0x2f,0x05);
- ...
- xx. outportb(0x2e,0xF6);
- yy. outportb(0x2f,0x05);
- ...

BIOS Setup

To enter the BIOS Setup pages, press during Power-On-Self-Test (POST).

If you have made any changes to the BIOS Setup which you think may be causing you problems, then when you enter the BIOS Setup pages select LOAD Optimal Defaults to load the default BIOS settings.

If your BIOS needs to be updated for any reason, please check the Blue Chip Technology Website www.bluechiptechnology.co.uk to see if there is a later BIOS, or alternatively contact Technical Support. Please note that, the motherboard and BIOS used in the Vario A1, has more options and functionality than is supported by the chassis.

Main Menu

The main menu allows you to select from a list of setup functions together with two exit choices. Use the arrow keys to select a specific item and press <Enter> to go to the sub-menu. Each item in the main menu is explained below:

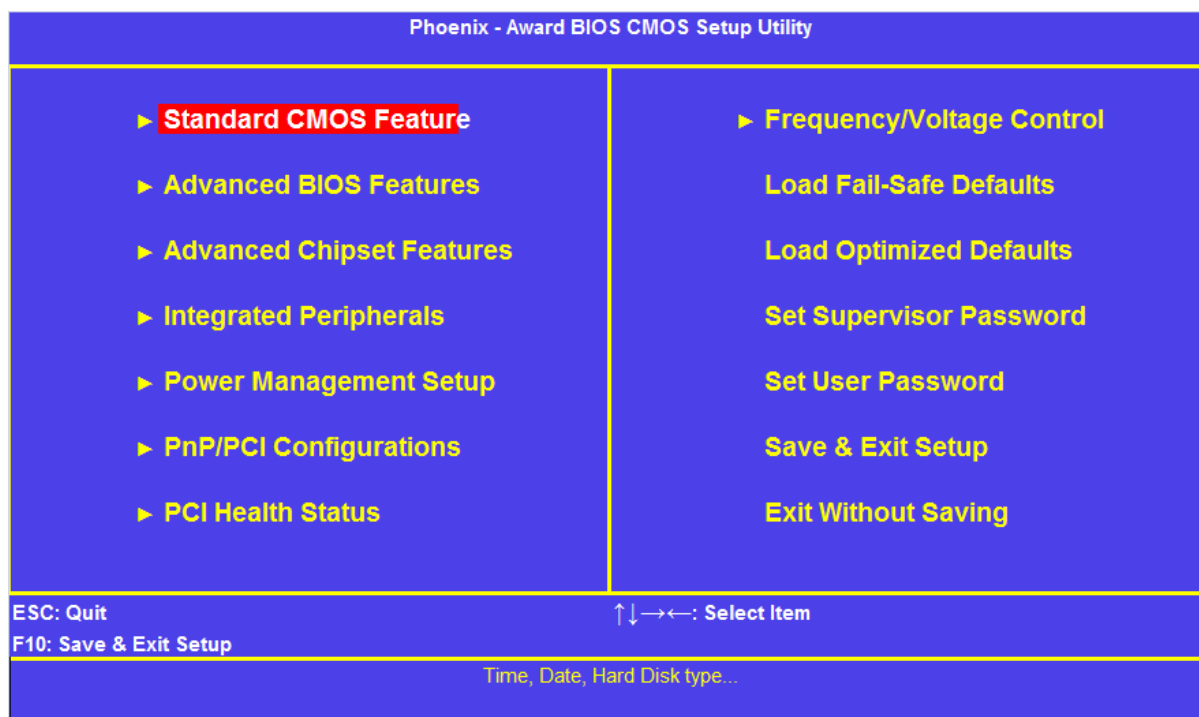

Standard CMOS Feature

This page displays the basic system configuration, such as system date, time and drive information. They all can be viewed or set up through this menu.

Advanced BIOS Features

The advanced system features can be set up through this menu, including boot up settings and nboot device Priority.

Advanced Chipset Features

The menu offers settings to control BIOS cache options as well as VGA settings, display type and TV Format.

Integrated Peripherals

All onboard peripherals can be set up through this menu. There are IDE devices, Super I/O devices such as Serial I/O and other USB devices... etc.

Power Management Setup

All the items related with power saving function features can be set up through this menu.

PnP/PCI Configurations

This menu offers options to assign resources.

PC Health Status

This setup enables you to read temperatures and voltages of your CPU/System.

Frequency/Voltage Control

This menu is used for enabling Spread Specturm.

Load Fail-Safe/Optimal Defaults

These settings can be loaded through these two menu options.

Save & Exit Setup

Save setting values to CMOS and exit.

Exit Without Saving

Do not change anything and exit the setup.

CMOS Features

Standard CMOS Features		Help Item
Date(mm:dd:yy)	[Apr, 28 2009]	Menu Level ► Change the day, month, year and century
Time (hh:mm:ss)	[14 : 15 : 45]	
▶ IDE Primary Master	[ST3160310CS]	
▶ IDE Primary Slave	[None]	
▶ IDE Secondary Master	[None]	
▶ IDE Secondary Slave	[None]	
Video	[EGA/VGA]	
Halt On	[No Errors]	
Base Memory	640K	
Extended Memory	514048K	
Total Memory	515072K	
↑↓→←: Move Enter: Select +/~/PU/PD: Value F10: Save ESC: Exit F1 General Help F5: Previous Values F6: Fail-safe defaults F7: Optimized defaults		

This sub-menu is used to set up the standard BIOS features, such as the date, time, drive and so on. Use the arrow up/down keys to select an item, then use the <+> or <-> keys to change the setting.

Advanced BIOS Features

Phoenix - Award BIOS CMOS Setup Utility		
Advanced BIOS Features		
		Help Item
▶ CPU Feature	[Press Enter]	
▶ Hard Disk Boot Priority	[Press Enter]	
Virus Warning	[Disabled]	Menu Level ▶
CPU L1 & L2 Cache	[Enabled]	
CPU L3 Cache	[Enabled]	
Hyper-Threading Technology	[Enabled]	
Quick Power On Self test	[Enabled]	
First Boot Device	[HDD-0]	
Second Boot Device	[Floppy]	
Third Boot Device	[[CD-0]	
Boot Other Devices	[Enabled]	
Boot up NumLock Status	[On]	
Gate A20 Option	[Fast]	
Typematic Rate Setting	[Disabled]	
Typematic Rate (Char/Sec)	[6]	
Typematic Delay (Msec)	[250]	
Security Option	[Setup]	
APIC Mode	[Enabled]	
MPS version Control for OS	[1.4]	
OS Select For DRAM > 64MB	[Non-OS2]	
Console Redirection	[Disabled]	
Baud Rate	[19200]	
Agent wait time(min)	[1]	
Agent after boot	[Disabled]	

↑↓→←: Move Enter: Select +/-: Value F10: Save ESC: Exit F1 General Help
 F9: Optimized Settings

The important settings in this page are quick and quiet boot, as well as the Boot Order. When Enabled, Quick Power On Self Test allows BIOS to skip certain tests during POST to speed boot time.

Advanced Chipset Features

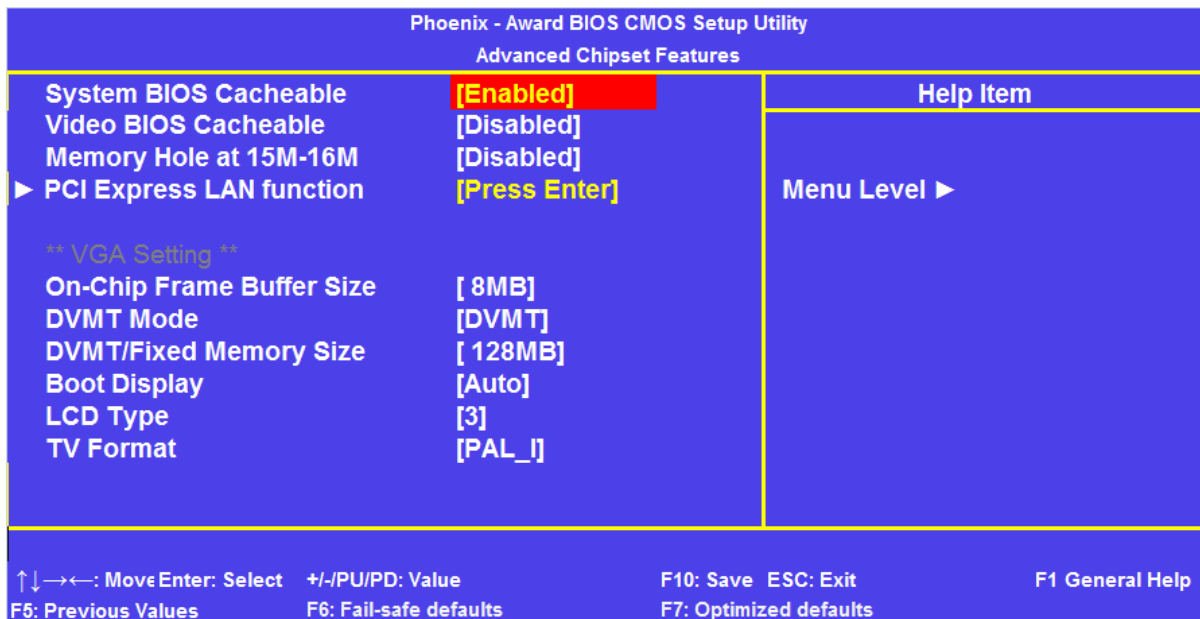

Options include being able to set the video memory size (the portion of Physical memory reserved for Video) For instance, if the unit has 512MB of Physical RAM fitted, and the DVMT memory size is set to 224MB, then this will leave only 288MB of Physical memory left for use by the operating system

The only Sub-menu is

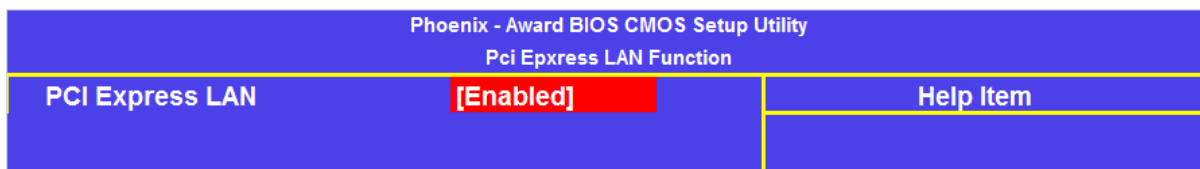

This menu allows the on –board Ethernet port to be enabled or disabled

Integrated Peripherals

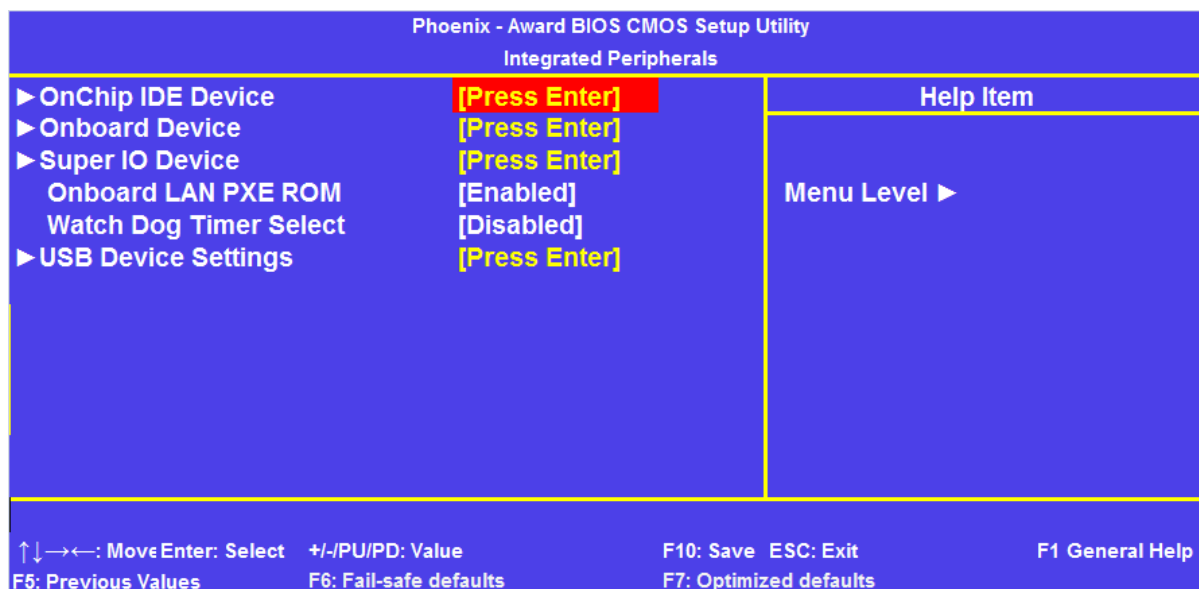

This Menu allows access to sub-menus to setup Drive options, control USB settings, Serial Port addressing. The menu also provides the ability to enable/disable PXE boot and the on-board Watchdog timer.

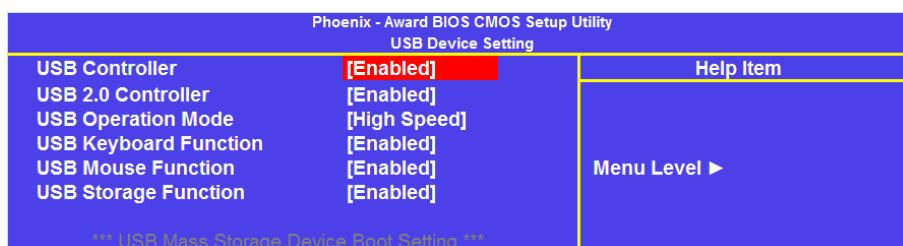

The USB Device settings page provides configuration options for USB2 as well as legacy USB devices.

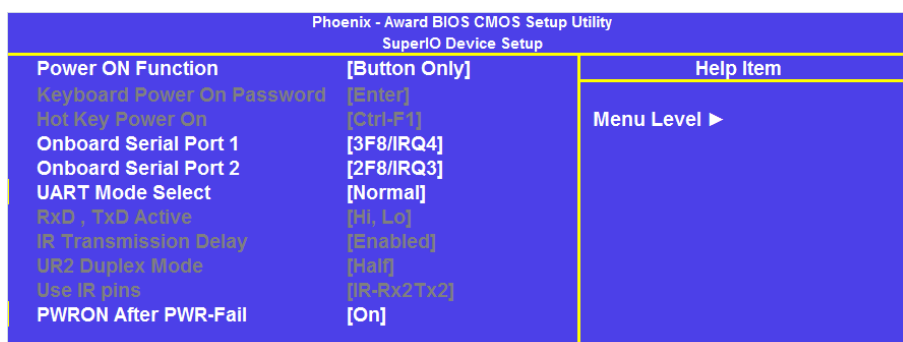

The Important setting in the Super IO page is Power On After power Fail. When set to ON, the unit will always turn on when power is applied to the unit.

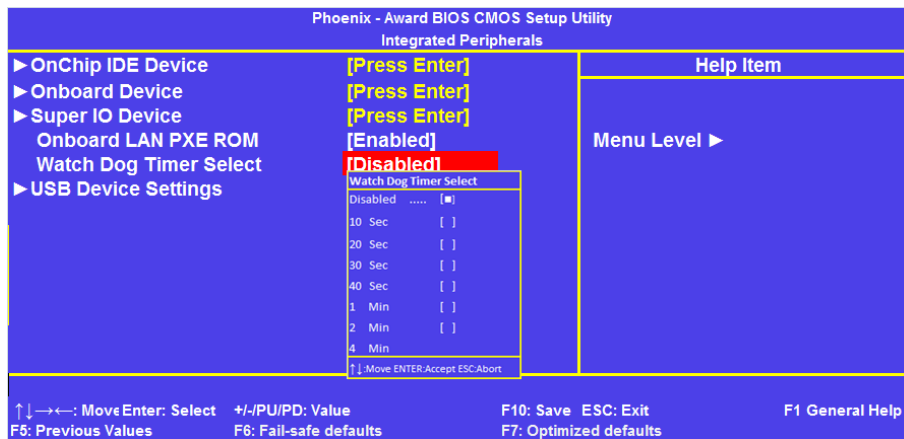

The Watch Dog Timer Select option allows setting a time out period

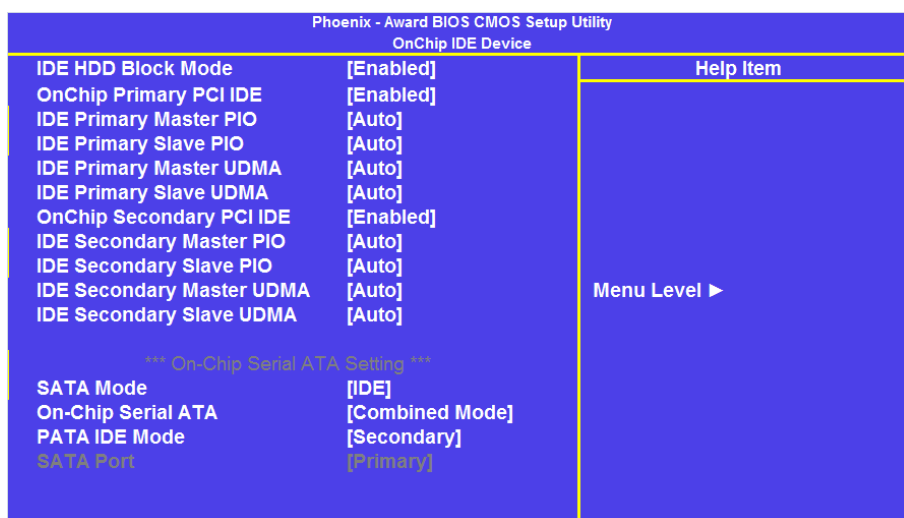

The Onchip IDE Page provides options for how the IDE ports are configured. These will be configured at time of manufacture and the user should not need to change any of these settings

Power Management Setup

Phoenix - Award BIOS CMOS Setup Utility		
Power Management Setup		
		Help Item
ACPI Function	[Enabled]	
ACPI Suspend type	[S1(POS)]	
Run VGABIOS if S3 resume	[Auto]	
Power Management	[User Define]	
Video Off Method	[DPMS]	
Video Off In Suspend	[Yes]	
Suspend type	[Stop Grant]	
MODEM Use IRQ	[3]	
Suspend Mode	[Disabled]	
HDD Power Down	[Disabled]	
Soft-Off by PWR-BTTN	[Instant-Off]	
CPU Therm-Throttling	[50.0%]	
Wake-Up by PCI Card	[Disabled]	
Power On by Ring	[Disabled]	
USB KB Wake-Up from S3	[Disabled]	
Resume by Alarm	[Disabled]	
Date(of Month) Alarm	[0]	
Time(hh:mm:ss) Alarm	[0 : 0 : 0]	
** Reload Global Timer Events **		
Primary IDE 0	[Disabled]	
Primary IDE 1	[Disabled]	
Secondary IDE 0	[Disabled]	
Secondary IDE 1	[Disabled]	
FDD,COM,LPT port	[Disabled]	
PCI PIRQ[A-D]#	[Disabled]	
Menu Level ►		
↑↓→←: Move Enter: Select +/-/PU/PD: Value F10: Save ESC: Exit F1 General Help F5: Previous Values F6: Fail-safe defaults F7: Optimized defaults		

This menu allows various options for controlling the power conditions of the Vario A1. Wake On LAN functionality can be turned on by Enabling the Wake-up By PCI Card setting

PnP/PCI Configurations

Phoenix - Award BIOS CMOS Setup Utility		
PnP/PCI Configurations		
		Help Item
Init Display First	[On Board]	Menu Level ►
Reset Configuration Data	[Enabled]	
Resources Controlled By	[Auto (ESCD)]	
x IRQ Resources	[Press Enter]	
PCI/VGA Palette Snoop	[Disabled]	
INT Pin 1 Assignment	[Auto]	
INT Pin 2 Assignment	[Auto]	
INT Pin 3 Assignment	[Auto]	
INT Pin 4 Assignment	[Auto]	
INT Pin 5 Assignment	[Auto]	
INT Pin 6 Assignment	[Auto]	
INT Pin 7 Assignment	[Auto]	
INT Pin 8 Assignment	[Auto]	

↑↓→←: Move Enter: Select +/-/PU/PD: Value F10: Save ESC: Exit F1 General Help
 F5: Previous Values F6: Fail-safe defaults F7: Optimized defaults

As there are no expansion options on the Vario A1, there is no need to change of these settings

PC Health Status

Phoenix - Award BIOS CMOS Setup Utility		
PC Health Status		
		Help Item
Shutdown Temperature	[Disabled]	Menu Level ►
CPU Warning temperature	[Disabled]	
Current System temperature	[59°C/ 138°F]	
Current CPU temperature	[52°C/ 125°F]	
SYAFAN	0 RPM	
CPUFAN	0 RPM	
Vcore	0.86V	
+12V	11.85V	
3.3V	3.36V	
VCC (V)	5.04V	
VBAT (V)	3.12V	
5VSB	5.04V	
Smart CPUFAN Temp	[Disabled]	
CPU Temp Toleran	5	

↑↓→←: Move Enter: Select +/-/PU/PD: Value F10: Save ESC: Exit F1 General Help
 F5: Previous Values F6: Fail-safe defaults F7: Optimized defaults

This menu displays temperature and voltage details which can be used to identify if the unit is operating out of specification.

The Warning Temperature can be set to provide warning information if the CPU temperature exceeds the set value. The Shut Down temperature, in conjunction with an ACPI OS, can be used to automatically shut down the system if the CPU temperature is exceeded.

Maintenance

On a regular basis the inside of the VARIO A1 should be cleaned out to prevent dust build up which could eventually lead to obstruction of the convection airflow within the unit and prevent efficient operation. Generally the enclosure design and the wiring layout will ensure that the cooling is stable. However, bear in mind that any modifications to the installation may cause a restriction of the air vents. After a period of several years, it may be necessary to replace the battery on the processor board, if it cannot maintain the CMOS memory whilst the AC power is disconnected.

Replacing the Battery

The processor board includes a small 3V lithium battery (type CR-2032) to retain the BIOS settings in the CMOS memory. Before attempting to replace the battery, please read the precautions detailed in the introductory section. Remember that even discharged batteries can present a real personnel hazard if mistreated.

Do NOT under any circumstances try to remove the battery with metallic tools (pliers, tweezers etc.). They will short out the battery with possible disastrous results.

Replace the battery by one of the same type, and that the clip is fully engaged. When the battery has been replaced, the BIOS settings will revert to their default settings. Reset them as necessary to suit your application.

Fuses

There are no user-serviceable or replaceable fuses within the unit.

Amendment History

Issue Level	Issue Date	Author	Amendment Details
1.0	26-05-2009	T Mck	First Release

Contact Details**Blue Chip Technology Ltd.****Chowley Oak****Tattenhall****Chester****CH3 9EX****U.K.****Telephone: +44 (0)1829 772000****Facsimile: +44 (0)1829 772001**www.bluechiptechnology.co.uk*Plasma PC Sales*PlasmaPC@bluechiptechnology.co.uk*Single Board Computer Sales*singleboardcomputer@bluechiptechnology.co.uk*Rack mount PC Sales*rackmountpc@bluechiptechnology.co.uk*Data and IO Sales*DataIO@bluechiptechnology.co.uk*Technical Support*Support@bluechiptechnology.co.uk