

WD-1

Multi-Function Watchdog Card



User Manual

WD-1

User Manual

Document Part N°	0127-1013
Document Reference	0127-1013.Doc
Document Issue Level	1.0

Manual covers PCBs identified WD-1 Rev. C

All rights reserved. No part of this publication may be reproduced, stored in any retrieval system, or transmitted, in any form or by any means, electronic, mechanical, photocopied, recorded or otherwise, without the prior permission, in writing, from the publisher. For permission in the UK contact Blue Chip Technology.

Information offered in this manual is correct at the time of printing. Blue Chip Technology accepts no responsibility for any inaccuracies. This information is subject to change without notice.

All trademarks and registered names acknowledged.

Blue Chip Technology Ltd.
Chowley Oak, Tattenhall
Chester, Cheshire
CH3 9EX.
Telephone : 01829 772000 Facsimile : 01829 772001.

Amendment History

Issue Level	Issue Date	Author	Amendment Details
0.2	21.06.89	PMD	First draft
1.0	14/8/97	SEJ	Window front cover and logo. See ECN 98/086

INTRODUCTION.....	1
OUTLINE DESCRIPTION	1
1.0 SPECIFICATIONS	2
1.1 Electrical Specification	2
1.2 Physical Specification	3
Electromagnetic Compatibility (EMC).....	4
EMC Specification	5
2.0 USER ADJUSTMENTS	6
2.1 Selecting the Base Port Address	6
2.2 Port Map	7
3.0 ELECTRICAL OPTIONS	10
3.1 Input/Output Connections.....	10
3.2 Watchdog Channel.....	11
3.3 Temperature Monitor.....	12
3.4 Fan Speed Monitor.....	13
3.5 Power Supply Monitor	13
3.6 Opto-Isolated External Inputs	13
3.7 Patch Inputs	15
3.8 Fault Indications.....	15
3.9 Enabling/Disabling Watchdog Functions.....	16
4.0 OPERATING GUIDE.....	17
4.1 Programming Guide	17
4.2 Example Programs.....	17
5.0 WATCHDOG TSR SOFTWARE	22
6.0 APPLICATION NOTES	26
6.1 Changeover Relay	26
6.2 External Inputs	26
APPENDIX A	27
APPENDIX B	29
PC/XT/AT Port Map	29
I/O Address Map	29

Contents

APPENDIX C	30
PC/XT Interrupt Map	30
APPENDIX D	31
AT Interrupt Map	31
APPENDIX F.....	32
Temperature Calibration Procedure	32

INTRODUCTION

The WD-1 card provides PC users with a way of ensuring the integrity of their machine in critical applications.

The card is set to port 300 Hex. Providing you do not have any other cards set to this address you can immediately run the TSR software (see Section 5). If you have other cards set to 300 Hex you must read section 2.1.

Some features of the card, however, such as using the watchdog or reading the temperature, require a more detailed understanding of the card and the relevant sections in this document should be read carefully.

The card's features are briefly discussed below and are highlighted in Figure 1.

1. All 4 supply rails are continually monitored via IC1. This chip detects undervoltage (+Ve rails) and overvoltage (-Ve rails) and generates a fail signal if either of these conditions occurs.
2. A fan fail detection circuit is provided which requires the use of a replacement fan. The fan generates a string of pulses whose frequency is proportional to the speed of the fan. These pulses feed into a monostable circuit which generates a fail signal if the frequency of the pulses falls below a preset value.
3. The temperature detection circuit performs two tasks. Firstly an LM35 temperature IC generates a voltage proportional to temperature. This voltage is compared to a pre-set voltage using IC2 and generates a fail signal if the temperature has exceeded 37°C. Secondly, this voltage is amplified and converted to a digital form via the ADC (IC4). This converts this signal into a temperature value which can be displayed to the PC monitor.

4. The watchdog channel includes a timer circuit whose timing period can be selected by the user. The channel should be sent a pulse at regular intervals via the user software to indicate processor activity. If the timer circuit fails to receive a pulse within the selected time period, then a fault condition will be generated. Use of this facility will require the user to insert the appropriate watchdog coding into his software.
5. The board is equipped with two opto inputs which can be arranged to assess various types of input signal. A full description of this facility can be found in section 3.6 and application notes are given in section 6.
6. Two additional TTL type inputs are provided for monitoring internal TTL level signals. Caution should be taken to ensure correct signal compatibility.
7. All the above fail signals feed into a logic circuit which allows user to select which functions are required. This selection/deselection is performed by writing a masking byte to a port. The address of this port is given section 2 along with its bit assignment details. The current PC status can be accessed at any time by reading a port byte. Details of this port can again be found in section 2.
8. In the event of a fault condition the aforementioned circuit will de-energise the relay, activate the buzzer and generate an interrupt.

This interrupt is link selectable and is used to activate the pop-up menu software.
9. The WD-1 has an IBM PC/XT/AT, 386, Model 30 62-way compatible bus.
10. In addition to the TSR Software, several BASIC programs are provided in the text and on the disk.

OUTLINE DESCRIPTION

This card is designed to continually monitor essential PC functions such as temperature, processor operating, power supplies and fan speed. In addition the WD-1 has the facility to monitor two remote inputs by means of opto isolated inputs. Each of the above functions can be enabled/disabled to suit user requirements. The card is equipped with a buzzer, a relay for remote sensing and software which provides a pop up menu in the event of fault condition. This menu displays the current PC status and allows the user to take appropriate action.

1.0 SPECIFICATIONS

1.1 Electrical Specification

Input Connections

Two opto inputs for external monitoring
(invert/non-invert: link selectable)

Input Voltage range : 3.5V - 8V (5V typical)

External opto power supply
(EXT/INT:link selectable)

Voltage range: : 3.5V - 8V (5V typical)

Sensed Fan Input

Voltage Range: : 3.5V - 12V

Minimum pulse frequency: : 240ppm

Output Connections

Single pole changeover relay (polarity sensitive)
(Relay link selectable)

Max Voltage range : 50V D.C., 30V A.C.

Max contact current : 750mA (resistive)

Cut-out Temperature : 37°C (factory set)

Cut-out Voltages : +/-4.75V (+/-5V)

: +/-11.65V (+/-12V)

Voltage Cut-out Hysteresis : 0.1V (+/-5V)

: 0.15 (+/-12V)

Max Power Dissipation : 1.75W

1.2 Physical Specification

Height	107mm
Width	19mm
Depth	132mm

Electromagnetic Compatibility (EMC)

This product meets the requirements of the European EMC Directive (89/336/EEC) and is eligible to bear the CE mark.

It has been assessed operating in a Blue Chip Technology Icon industrial PC. However, because the board can be installed in a variety of computers, certain conditions have to be applied to ensure that the compatibility is maintained. It meets the requirements for an industrial environment (Class A product) subject to those conditions.

- The board must be installed in a computer system which provides screening suitable for the industrial environment.
- Any recommendations made by the computer system manufacturer/supplier must be complied with regarding earthing and the installation of boards.
- The board must be installed with the backplate securely screwed to the chassis of the computer to ensure good metal-to-metal (i.e. earth) contact.
- Most EMC problems are caused by the external cabling to boards. It is important that any external cabling to the board is totally screened, and that the screen of the cable connects to earth at both ends of the cable. It is recommended that round screened cables with braided wire screen are used in preference to those with foil screen and drain wire. With the terminal block connection to the card there is no space available for an earth point on the board mounting bracket. It is recommended that the screen be connected to the metal body of the PC (and hence earth) by the shortest possible “pig-tail”. The BCT Icon chassis has these available adjacent to the expansion area. Unscreened cable will not be adequate unless it is contained wholly within the cabinetry housing the industrial PC and carefully routed.

- Ensure that the screen of the external cable is bonded to a good RF earth at the remote end of the cable.

Failure to observe these recommendations may invalidate the EMC compliance.

Warning

This is a Class A product. In a domestic environment this product may cause radio interference in which case the user may be required to take adequate measures.

EMC Specification

A Blue Chip Technology Icon industrial PC fitted with this card meets the following specification:

Emissions: EN 55022:1995

Radiated	Class A
Conducted	Class A & B

Immunity: EN 50082-2:1995 incorporating

Electrostatic Discharge	EN 61000-4-2 Performance Criteria B
-------------------------	--

Radio Frequency Susceptibility	ENV 50140 Performance Criteria A
--------------------------------	-------------------------------------

Fast Burst Transients	EN 61000-4-4 Performance Criteria B
-----------------------	--

2.0 USER ADJUSTMENTS

2.1 Selecting the Base Port Address

The board may be located in any 62 pin slot in the PC mother board but must be set up to appear at a specified position (or 'address') in the port map. Available positions are shown in the IBM-PC Technical Reference Guide. However, for those who do not possess a copy of this document a good place is the location normally allocated to the prototyping card as supplied by IBM. This address is 300 Hex or 768 decimal.

All Blue Chip Technology cards are preset to this address at the factory.

However, no two devices should be used while set to the same address since contention will occur and neither board will work. If your machine contains a card with a conflicting address then another reasonably safe address is 200 to 21F (Hex).

A set of links is provided on the board to set the base address of the board within the IBM-PC port map. The address is in binary with the presence of a link representing a 0 and the absence of a link representing a 1.

To set the base address to 768 Decimal (300 Hex) set the following pattern on the links as indicated below:

Figure 1 - Selecting the Base Address

Note: View board with back panel on RHS.

Top 6 Bits of port address on links.

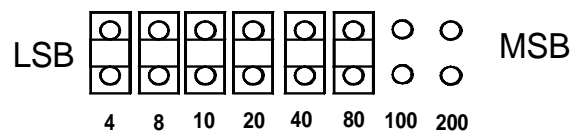

.More example addresses are shown in Appendix A.

Note: No two cards must occupy the same address.

2.2 Port Map

Three ports are used on the WD-1 to control all functions of the card. These are described below:

Address	Read	Write
Base + 0	Status Byte	Mask Byte
Base + 1	ADC Value	Start Conversion
Base + 2	N/A	Watchdog Reset bit

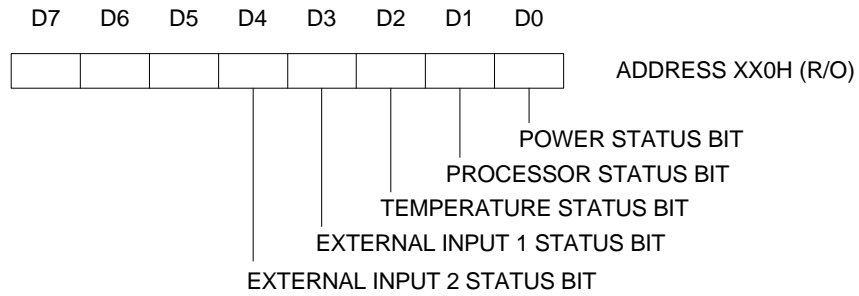
4. Status Byte

N.B. All above functions are:

1 = Fail 0 = OK

ADC BUSY BIT

0 = BUSY

1 = NOT BUSY

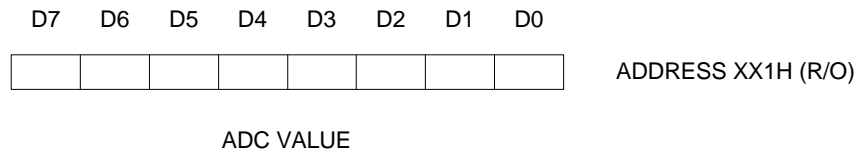
6. ADC Value

3.0 ELECTRICAL OPTIONS

3.1 Input/Output Connections

Two 8-way Klippon screw terminals are provided on the PC rear panel of the board for external connections. The terminals are labelled in the following diagram.

Connector P1

TOP >	P1/1	0	: Relay Common
	P1/2	0	: Relay Normally Closed
	P1/3	0	: Relay Normally Open
	P1/4	0	: EXT i/p 1+
	P1/5	0	: EXT i/p 1-
	P1/6	0	: EXT i/p 2+
	P1/7	0	: EXT i/p 2-
	P1/8	0	: EXT +Ve
	P1/9	0	: EXT -Ve
	P1/10	0	: NC
	P1/11	0	: NC
	P1/12	0	: NC
	P1/13	0	: NC
	P1/14	0	: NC
	P1/15	0	: NC
	P1/16	0	: NC

3.2 Watchdog Channel

The watchdog channel is designed to monitor integrity by periodically receiving a reset signal from the system. An example program for generating such a signal can be found in section 4.2.5. The interval between these reset signals is link selectable as indicated below. Should the WD-1 card fail to receive a watchdog reset at any time during the reset period, then a fault signal will be generated.

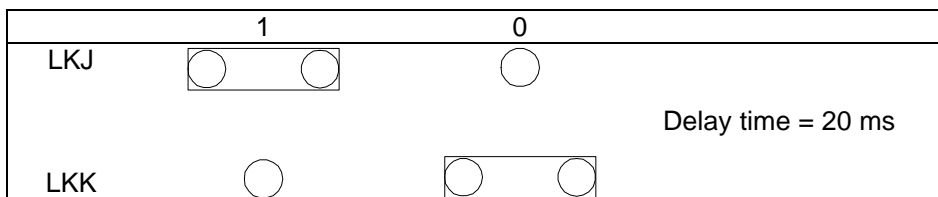
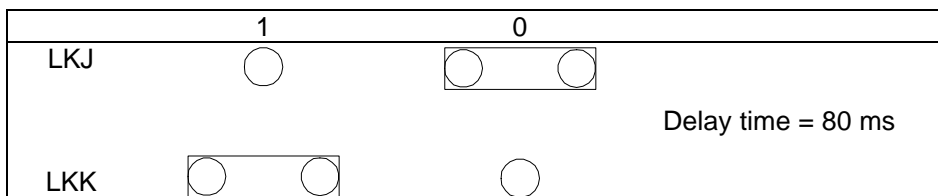
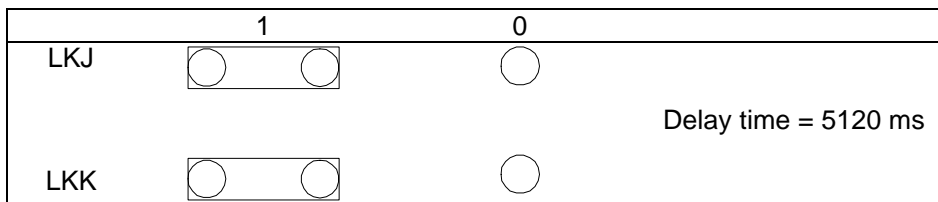
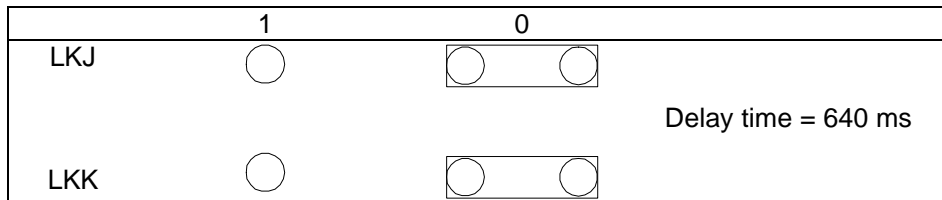

The watchdog channel has an additional link, LKL. This link allows the watchdog facility to be installed automatically from start up after a preset delay to allow the system to access its software. This is offered for applications where processor integrity is imperative. Alternatively, the watchdog facility may be installed manually i.e. through the WD-1 TSR software. The link arrangement is as shown below.

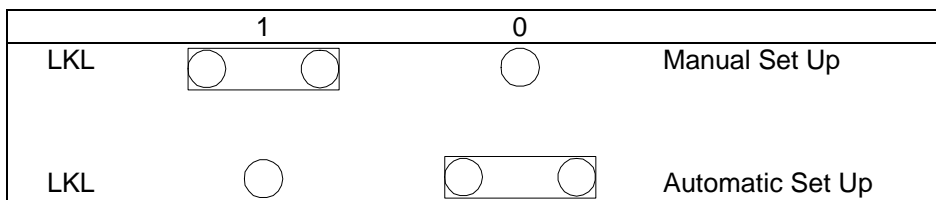

3.3 Temperature Monitor

The WD-1 temperature sensing circuitry serves two purposes. First it provides a fault indication of the ambient temperature exceeds a precept value 37°C. Second it provides an accurate temperature measurement. This value is displayed in the WD-1 TSR status window and an example program can be found in section 4.2.3 showing how this value can be read.

The temperature sensor can be located off the WD-1 card and at a specified location within the PC using the 3-way molex connector.

Pin details of P3 are given below:

>	P3/1	0	: 0V
	P3/2	0	: Output
	P3/3	0	: +5V

3.4 Fan Speed Monitor

In order to use this facility a special fan with a pulsed sensor output is required, such as a hall effect. Possible sources of such fans are ETRI and PAPST. However, if in doubt, contact Blue Chip Technology Sales Department. The fail speed is preset to 240ppm (pulses per minute) i.e. 240rpm for a 1ppr fan. The range of input voltages is 3.5V to 12V. Connections to the fan are made via the molex header P2 as shown below:

>	P2/1	0	: 0V
	P2/2	0	: Sensor input from fan
	P2/3	0	: 0V

3.5 Power Supply Monitor





The WD-1 card senses all four supply rails (+5V, -5V, +12V, -12V).





The card generates a fail signal if any rail falls below +4.75V, +11.65 (+5V, +12V) or rises above -4.75, -11.65V (-5V, -12V). The fail signal is cleared when the voltage rises or falls to +4.85 +11.80V and -4.85V, -11.80V respectively.





N.B. All the above voltage values are preset to within a tolerance of +/-0.03V (+/-5V) and +/-0.05V (±/-12V).



3.6 Opto-Isolated External Inputs

Two opto inputs are provided on the WD-1 card for additional monitoring of remote equipment such as power supplies, relays etc. These inputs can be configured for voltage level (5V typically) or volt free contact inputs. Examples of these arrangements can be found in section 6. The opto inputs provide a link selectable internal isolated +5V, 0V or external +5V, 0V opto supply (links LKM & LKN). The outputs of the opto isolators are also link selectable for inverting and no-inverting input set ups (links LKG & LKH).

	Internal	External		
LKM			+Ve	Internal Isolated +5V, 0V
LKN			-Ve	

	Internal	External		
LKM			+Ve	External Isolated +5V, 0V
LKN			-Ve	

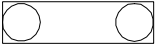
LKH				Inverting Configuration
LKG				

LKH				Non-inverting
LKG				

The normal input voltage for the opto-isolators is 5V. However, higher input voltages can be used if the user changes the values of resistors R37 and R38. The value of these resistors must be calculated to ensure that the current passed through the opto-isolator will drop 1.5V constantly.

Required resistance = (Input Voltage-1.5)/0.01 Ohms.

The following table gives some typical examples using preferred resistor values.

Input Voltage	Resistor Value
---------------	----------------

5V	330R (Fitted as standard)
10V	820R
12V	1K
24V	2K2

3.7 Patch Inputs

Two further link selectable TTL inputs are provided PTCH1 & PTCH2 for additional internal PC monitoring. These connections are made by directly soldering leads into the two solder holes adjacent to links LKC & LKD. These inputs **MUST** be TTL compatible (+5V, 0V), with logic 1 (+5V) providing a fail condition. The linking arrangement shown below and the links to ground **MUST** be included if these additional inputs are not required.

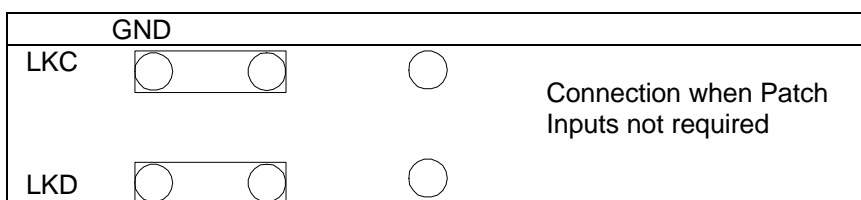
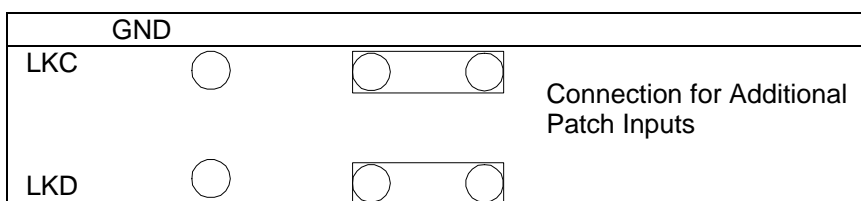

3.8 Fault Indications

In the event of a fault condition several actions may result. A link selectable (LKB) buzzer is provided for annunciation in the immediate vicinity of the PC.

A link selectable (LKF) relay is also provided which de-energises and thus changes over contacts in the event of a fault. This is ideal for remote monitoring of the PC. The relay outputs include diodes which allow the relay and its remote cable assemblies to be scrutinised for damage. A fault condition

can also generate an interrupt. Any one interrupt from 2 to 7 may be selected using LKE. This interrupt is used to activate the WD-1 TSR Pop up menu.

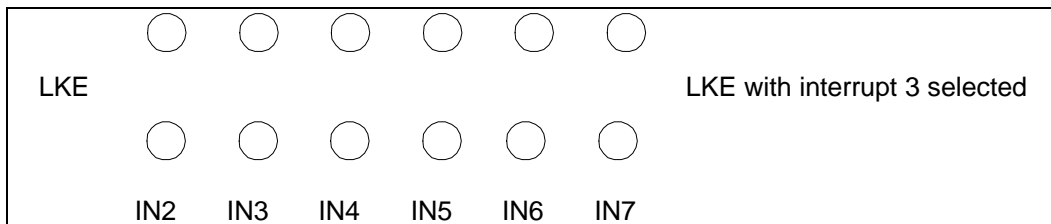

N.B. IN3 is selected at the Blue Chip Technology factory and the WD-1 TSR software defaults to this setting.

3.9 Enabling/Disabling Watchdog Functions

All the aforementioned WD-1 facilities can be enabled/disabled by writing a mask to the WD-1 card. In addition the current PC status can be read from the WD-1 card. Software details of both these actions can be found in section 4.

4.0 OPERATING GUIDE

4.1 Programming Guide

The following guides are applicable for Microsoft BASIC A or GWBASIC. The following programming functions are essential for writing to and reading from the WD-1 card.

a) INPUT

X = INP (P)

Returns the byte from port P and assigns this value to the variable, X.

b) OUTPUT

OUT P,D

Outputs the byte D to port P.

4.2 Example Programs

4.2.1 Entering the Base Address

Before any read or write instructions can be performed, the base address must be entered. This value **MUST** coincide with that set on the card by links (LKA).

Program: BASEADD.BAS
(Provided on Demonstration Disk).

```
10 REM WD-1 BASE ADDRESS PROGRAM
20 CLS 'CLEAR SCREEN
30 INPUT "ENTER BASE ADDRESS OF WD-1 CARD (IN DECIMAL) ",BASE
40 REM BASE IS THE BASE ADDRESS FOR ALL I/O OPERATIONS
```

4.2.2 Reading the WD-1 Status

* The following program will access the status byte and indicate its present logic level.

N.B. Logic 1 indicates fault.

Program STAT.BAS
(Provided on Demonstration Disk)

```
200 REM Reading the status Program
210 PRINT:PRINT
215 INPUT "Enter the base address in decimal ",BASE
216 PRINT BASE:PRINT
220 PRINT "Function Status"
230 STATUS = BASE 'Status Register Address
240 A = INP(STATUS) 'Read the Status
250 STAT = 1
260 READ A$ : PRINT A$
270 LEV = A AND STAT
280 IF LEV>0 THEN LL=1 ELSE LL=0
290 PRINT " " LL
300 STAT = STAT*2
310 IF STAT <33 GOTO 260
320 END
330 REM Data String
340 DATA "/POWEROK "
350 DATA "/WDOGOK "
360 DATA "/TEMPOK "
390 DATA "/EXT1OK "
400 DATA "/EXT2OK "
410 DATA "/FANOK "
```

4.2.3 Reading the Temperature

The following program will access the ADC and provide a temperature reading.

Program TEMP.BAS

(Provided on Demonstration Disk)

```
50  REM READING THE TEMPERATURE PROGRAM
55  INPUT "Enter the base address in decimal",BASE
60  SCON = BASE+1 'START CONVERSATION CONTROL BIT ADDRESS
70  ADCSEL=BASE+1 'ADC SELECT CONTROL BIT ADDRESS
80  STATUS = BASE 'STATUS REGISTER ADDRESS
90  OUT SCON,0    'START THE CONVERSATION
100 IF INP(STATUS) AND &H40 < 1 GOTO 100; LOOP UNTIL ADC NOT BUSY
130 C = INP (ADCSEL) 'ELSE READ THE ADC
140 TEMP = C/4      'CONVERT TO TEMP IN DEGREES C"
150 PRINT "The temperature is " TEMP "degrees C"
160 FOR I = 1 TO 100: NEXT 'DELAY
170 GOTO 90        'REPEAT
```

N.B. This program will run continually and can be halted by pressing the Control (CTRL) and Break keys at the same time.

4.2.4. Writing a Mask to the WD-1 Card

This program will write a mask to the WD-1 card to enable/disable the functions. The program is designed to load in the decimal value of the mask byte.

The bit assignment of each function is listed below:

Data Bit	Function	Value
D0	Power	1
D1	Wdog	2
D2	Temp	4
D3	Ext1	8
D4	Ext2	16
D5	Fan	32
D6	Patch1	64
D7	Patch2	128

To determine the value of the mask byte, add the corresponding numbers of the functions to be enabled. Example: If the Power and Patch2 are to be enabled then the value written to the mask is 129 i.e. $128 + 1$.

Program: MASK.BAS
(Provided on Demonstration Disk)

```

500 REM WRITING A MASK TO WD-1
510 PRINT:PRINT
515 INPUT "Enter the base address in decimal", BASE
520 INPUT " ENTER THE MASK VALUE (IN DECIMAL)",WDMASK
530 MASK = BASE
540 OUT MASK,WDMASK
550 STOP

```

4.2.5 Typical Watchdog Reset Software

This program is designed to generate the watchdog reset pulses used to confirm processor integrity. This subroutine should be installed in the user's own software with GOSUB commands periodically inserted into the coding. The amount of allowable coding between these GOSUB commands will be governed by the speed of the user's machine, the type of coding and the user's application, all of which must be considered before selecting the reset delay links (LKN & LKM) on the WD-1 card.

```
10 INPUT "Enter the base address in decimal",BASE
15 REM Example of user coding
20 X = INP(B)
30 WHILE this DO that
40 OUT here(value)
.
.
60 GOSUB 1000          'CALL SUBROUTINE
70 REM more user coding
80 .....
.
.
90 GOSUB 100          'CALL SUBROUTINE
100 .....
.
.
1000 REM WATCHDOG RESET GENERATING SOFTWARE
1010 WDOG = BASE + 2
1020 OUT WDOG,0
1030 RETURN
```

5.0 WATCHDOG TSR SOFTWARE

The Watchdog Terminate and Stay Resident (TSR) software is run by typing WD at the DOS prompt. The operator is then presented with two menus of options as follows:

- 0 Exit without Installing
- 1 Set Port Address
- 2 Set Mask Options
- 3 Save Options
- 4 Switch Bell on
- 5 Interrupt No: 3
- 6 Install Watchdog TSR

The operator can select an option from the menu by: Typing the number of that option or

Moving the Bar onto the desired option using the cursor keys and then selecting that option by hitting Return or pressing the Space Bar.

The Setup Options perform the following functions:

0 Exit without Installing

Returns to DOS without installing the watchdog TSR software.

1 Set Port Address

This option is used to change the port address of the watchdog card from its default of 300 Hex. The existing port address is displayed and the operator is prompted for the new address. The new address is entered in hexadecimal.

2 Set Mask Options

This option leads to the use of the second menu on the screen, the Mask Options Menu. From this menu the operator can disable and enable any of the six watchdog inputs.

The Mask Options Menu appears as follows:

0	Back to Setup Menu	
1	Temperature:	Disabled
2	Fan:	Disabled
3	Power Supply:	Disabled
4	Watchdog:	Disabled
5	External 1:	Disabled
6	External 2:	Disabled

The operator selects the option using the same method used for the previous menu. When an option is selected the menu is updated to show its current status. For example, if input 3, power supply, was disabled, then selecting Option 3 would enable it.

Selecting Option 3 again would then switch back to Disabled and so on. The operator should select which of the watchdog inputs is to be enabled. If the operator wants to enter a message which will be displayed if that input fails, then the option is selected and 'M' entered. The operator will then be prompted by 'Message ?'. The message should be entered and terminated by pressing Return. Selecting the 'M' option automatically enables the appropriate input.

When the operator has enabled all of the required inputs, and entered any messages, Option 0 should be selected in order to return to the Setup Options Menu.

3 Save Options

This option is selected when the operator wishes to make a copy on disk of all the options selected. This copy can then be used to configure the software automatically without operator intervention. When the option is selected, the operator is prompted with 'Filename ?'. The filename should then be entered, terminated by pressing Return. The filename can be any legal MS-DOC file specification. Details of how to use this file are given at the end of the user instructions.

4 Switch Bell On

When this option is selected, if a fault occurs and the TSR pops up, the terminal bell will sound to alert the user. If this option is not selected, then no bell will sound.

5 Interrupt No: 3

This selects the number of hardware interrupt that the Watchdog card will use. The software can use interrupt numbers 2 to 7, with 3 being the default. Selecting this option increases the Interrupt No. displayed, up to 7, and after 7 goes back to 2.

6 Install Watchdog TSR

Option 6 should be selected when all other required options have been selected. The TSR will now be installed, and the operator will be returned to the DOS prompt.

When the Watchdog TSR is installed.

After the watchdog TSR is installed, it will automatically pop up when one or more of the watchdog inputs develops a fault. Two options are then available.

Firstly, 'Q' for quit; this takes you out of the TSR without doing anything. The watchdog will not respond to future faults and the current fault will not be cleared. This option should be avoided. Masking out the fault is available by typing 'M'. This disables the faulty input and re-enables the watchdog card without the faulty input. 'Q' to quit can then be safely selected.

The watchdog TSR can also be 'popped up' by typing:

CTRL ALT W

This can be typed at any time, including when another program is executing. This has the same options as above, but with a further option to Kill the watchdog TSR. Killing involves removing the watchdog TSR software from memory and disabling the watchdog card. The TSR is killed by typing CTRL K.

Using the Processor Watchdog

On installing the TSR software, the watchdog channel is disabled for approximately 20 seconds. This allows the time for the user coding to be installed and executed.

Using the file created by Save Options

When option 3 is selected from the Setup Options menu, it generates a file containing the current selection of options. This file can be used later for installing the watchdog without operator intervention.

This is achieved by issuing the following commands:

WD filename

Filename should be the name of the file to which the operator saved the details. This installs the watchdog TSR without prompting or displaying anything, other than a 'Watchdog Installed' message.

The operator can also examine the options that have been set up in this file by typing:

WD filename /E

6.0 APPLICATION NOTES

6.1 Changeover Relay

The following sections are intended to show some typical applications of the WD-1 card. The relay output has two diodes which allows the relay output has two diodes which allows the relay and its connections and cabling to be scrutinised as well as providing remote PC fault indications. This set up will require additional remote sensing circuitry. Alternatively the contacts may be arranged to energise/de-energise a remote relay. Both configurations are shown in fig 6.1 - 6.2

N.B. NEVER apply more than 50V DC or 30 AC to the relay contacts and never exceed more than 750mA resistive current.

6.2 External Inputs

The following configurations are suggested applications for the opto isolated inputs EXT1 and EXT2. The first set up (fig 6.3) shows a volt free contact utilising the on board isolated +5V, 0V.

The second (fig 6.5) has Voltage level input using an external power supply to drive the opto inputs.

N.B. The maximum current that can be drawn from pins 4/6 is 10mA per pin.

Whilst every effort has been taken to ensure that the information provided is accurate, Blue Chip Technology cannot assume responsibility for any errors in this manual or their consequences. Should any errors be detected, the company would greatly appreciate being informed of them. A policy of continuous product development is operated, resulting in the contents of this document being subject to change without notice.

APPENDIX A

Note: View board with back panel on RHS.

Address Settings for Port 300H

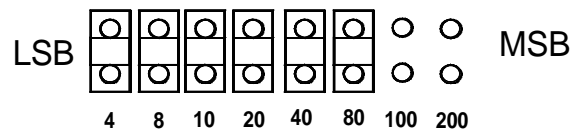

Address Settings for Port 200H

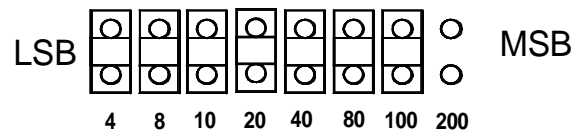

Address Settings for Port 204H

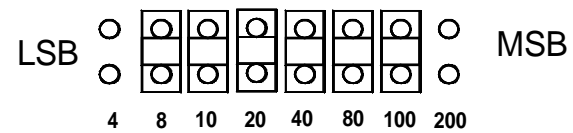

Address Settings for Port 210H

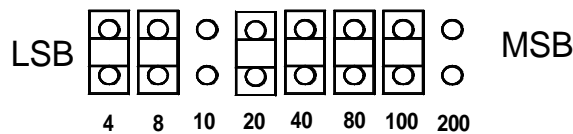

Address Settings for Port 220H

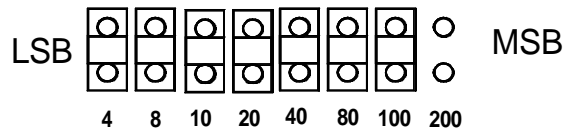

Address Settings for Port 230H

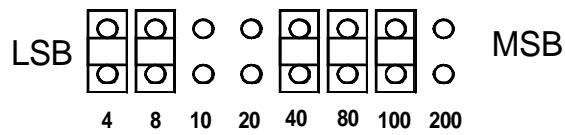

APPENDIX B

PC/XT/AT Port Map I/O Address Map

Address

000-01F	DMA Controller 1 (8237A-5)
020-03F	Interrupt Controller 1 (8259A)
040-05F	Timer (8254)
060-06F	Keyboard Controller (8742) Control Port B
070-07F	RTC and CMOS RAM, NMI Mask (Write)
080-09F	DMA Page Register (Memory Mapper)
0A0-0BF	Interrupt Controller 2 (8259)
0F0	Clear NPX (80287) Busy
0F1	Reset NPX (80287)
0F8-0FF	Numeric Processor Extension (80287)
1F0-1F8	Hard Disk Drive Controller
200-207	Reserved
278-27F	Reserved for Parallel Printer Port 2
2F8-2FF	Reserved for Serial Port 2
300-31F	Reserved
360-36F	Reserved
378-37F	Parallel Printer Port 1
380-38F	Reserved for SDLC Communications, Bisynchronous 2
3A0-3AF	Reserved for Bisynchronous 1
3B0-3BF	Reserved
3C0-3CF	Reserved
3D0-3DF	Display Controller
3F0-3F7	Diskette Drive Controller
3F8-3FF	Serial Port 1

APPENDIX C

PC/XT Interrupt Map

<u>Number</u>	<u>Usage</u>
NMI	Parity
0	Timer
1	Keyboard
2	Reserved
3	Asynchronous Communications (Secondary) SDLC Communications
4	Asynchronous Communications (Primary) SDLC Communications
5	Fixed Disk
6	Diskette
7	Parallel Printer

APPENDIX D

AT Interrupt Map

<u>Level</u>	<u>Function</u>
	Microprocessor NMI Parity or I/O Channel Check
CTLR 1	CTLR 2 (Interrupt Controllers)
IRQ 0	Timer Output 0
IRQ 1	Keyboard (Output Buffer Full)
IRQ 2	Interrupt from CTLR 2
	IRQ 8 Real-time Clock Interrupt
	IRQ 9 Software Redirected to INT 0AH (IRQ 2)
	IRQ 10 Reserved
	IRQ 11 Reserved
	IRQ 12 Reserved
	IRQ 13 Co-processor
	IRQ 14 Fixed Disk Controller
	IRQ 15 Reserved
IRQ 3	Serial Port 2
IRQ 4	Serial Port 1
IRQ 5	Parallel Port 2
IRQ 6	Diskette Controller
IRQ 7	Parallel Port 1

APPENDIX F

Temperature Calibration Procedure

Detailed below is the test and calibration procedure carried out by Blue Chip Technology before despatch of the WD-1 card.

Equipment required:

- PC Computer System
- DVM
- WD-1 Card

Method:

1. Fit the WD-1 card into the computer.
2. Connect the DVM across the terminals on the WD-1 card marked TP1 (MAX) and TP3 (GND).
3. Run the program TEMP.BAS in either the Microsoft Basic A or GWBASIC environment.
4. Read the DVM and multiply this reading by 100 to obtain the temperature in degrees C. Compare this result with that displayed on the PC monitor and adjust the potentiometer and adjust the potentiometer RV3 until these two measurements are the same to within 0.25 of a degree.
5. Check the DVM reading is unaltered and if unchanged the calibration is complete. If however, the DVM reading differs from that originally obtained, repeat 4. until the two values compare.
6. Type CTRL and Break keys to stop the program.

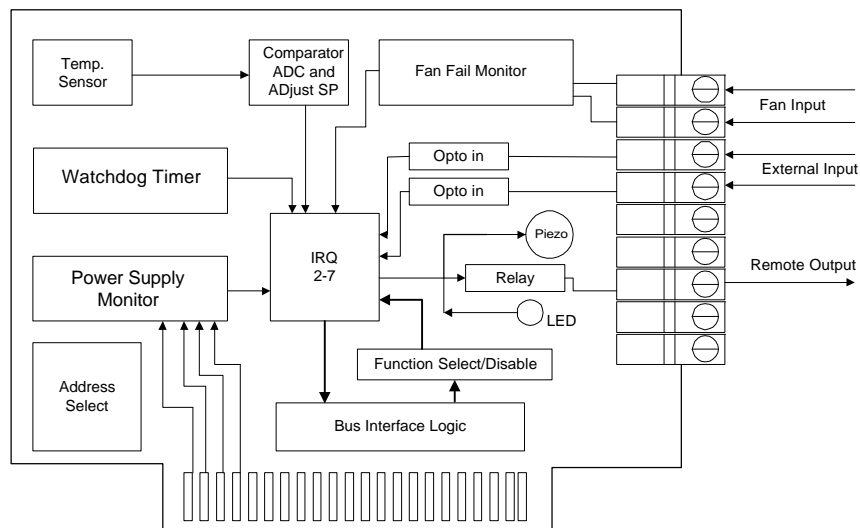

Fig.1 Block Diagram

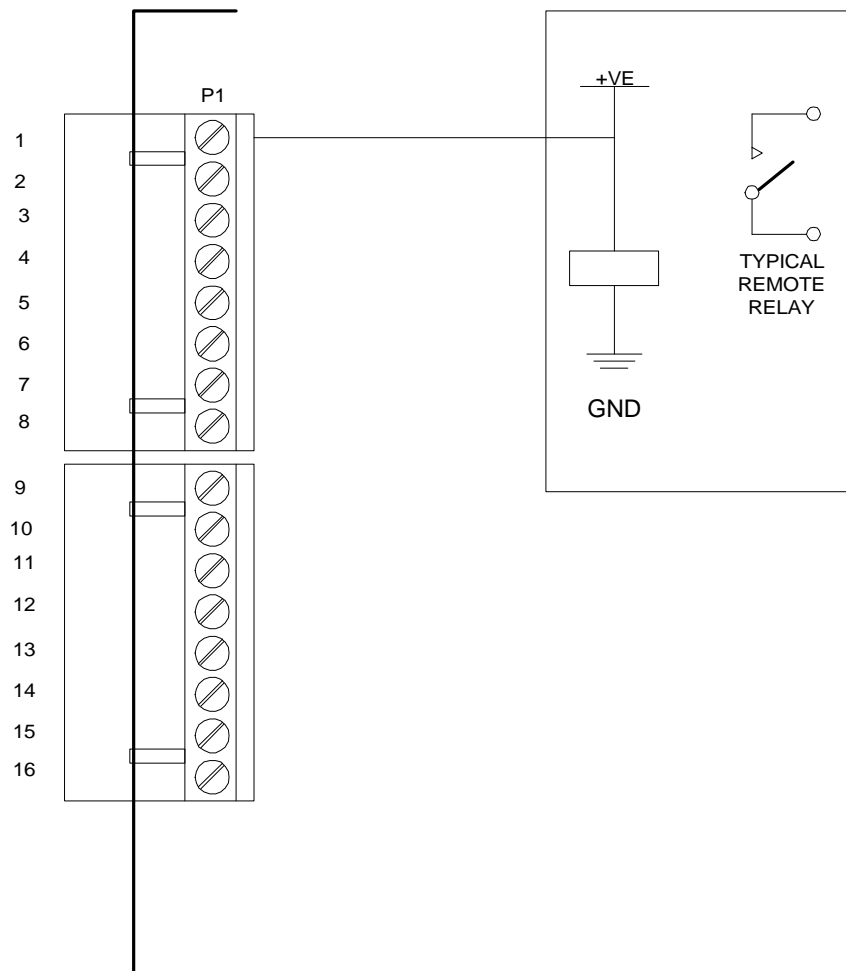

Fig.6.1 Using RL1 to drive remote relays

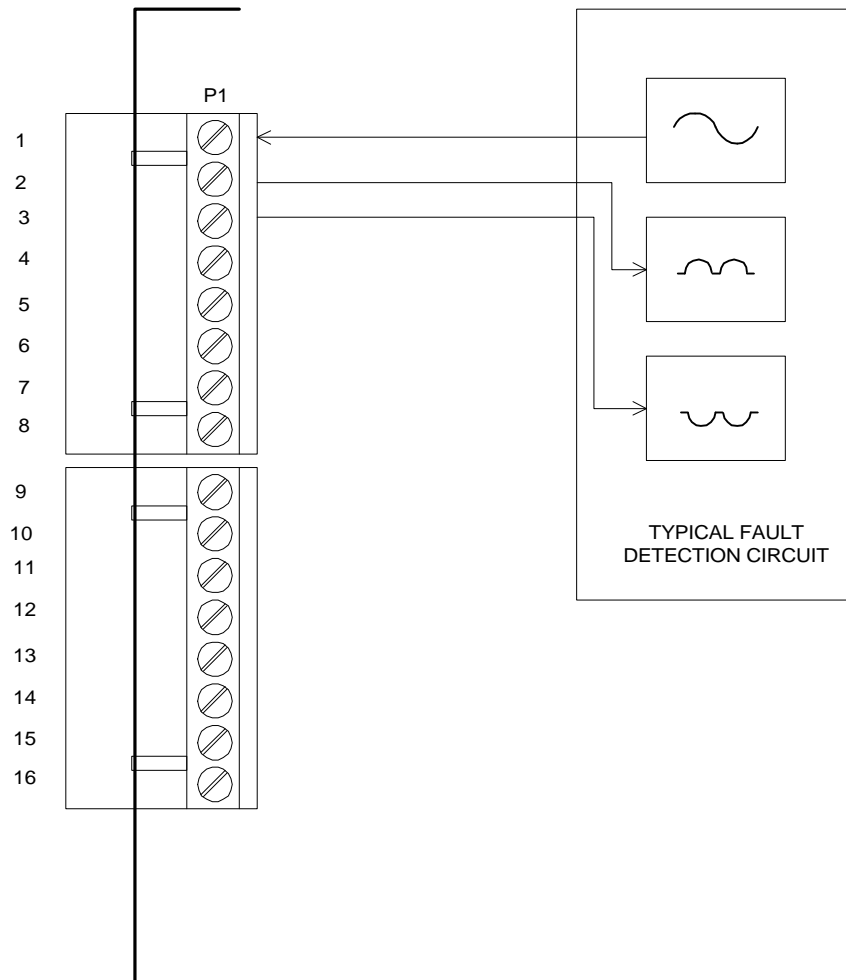

Fig.6.2 Using RL1 with fault detection circuitry

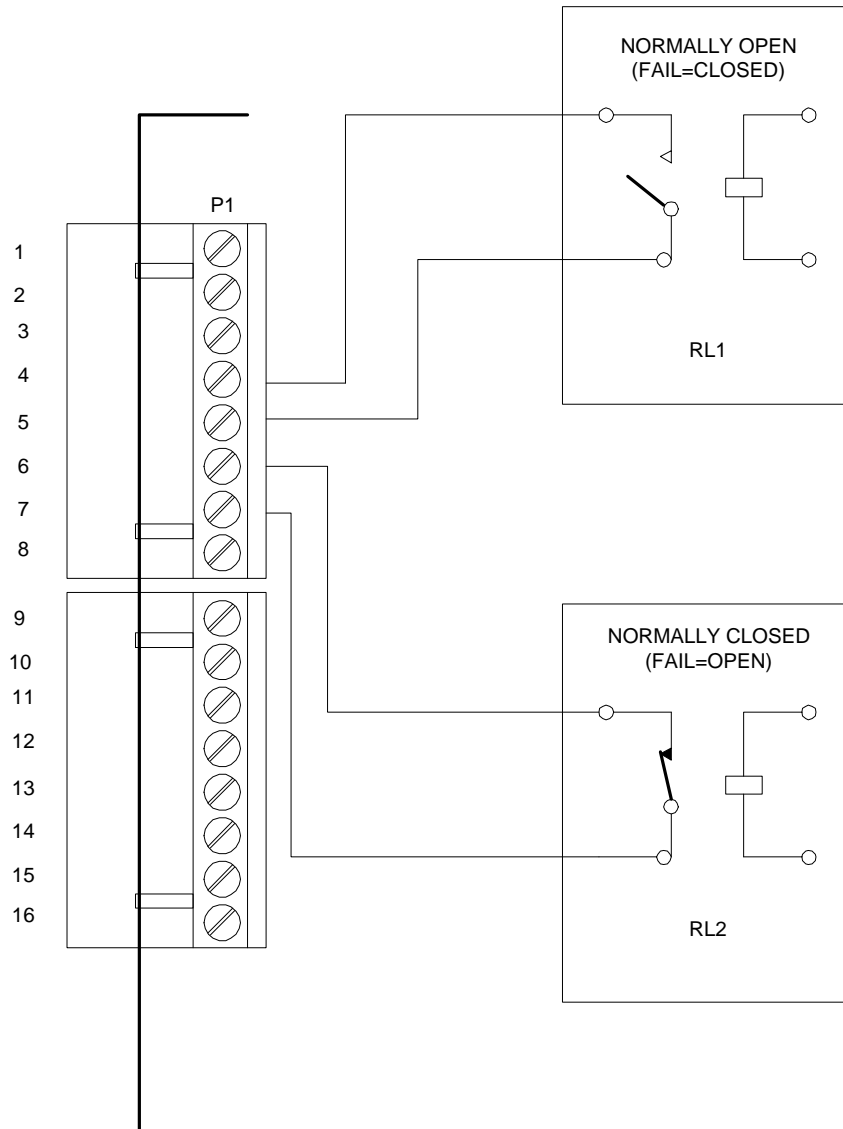

Fig.6.3 Remote relays with RL1 normally open and RL2 normally closed

LINK	FUNCTION	POSITION
LKN	INTERNAL +5V	INT
LKM	INTERNAL 0V	INT
LKH	NORMALLY OPEN RELAY INPUT	INT
LKG	NORMALLY CLOSED RELAY INPUT	NON INV

Fig.6.4 Link settings on WD-1 card for Fig 6.3 setup

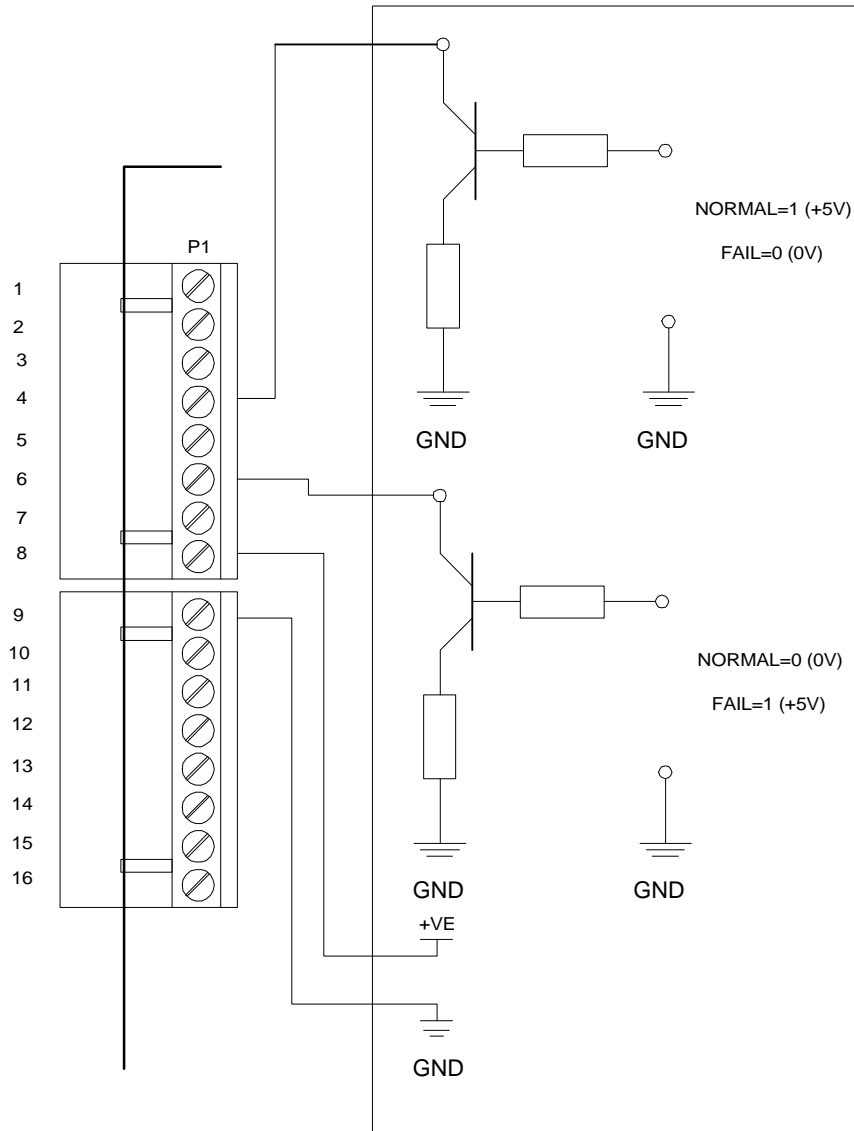
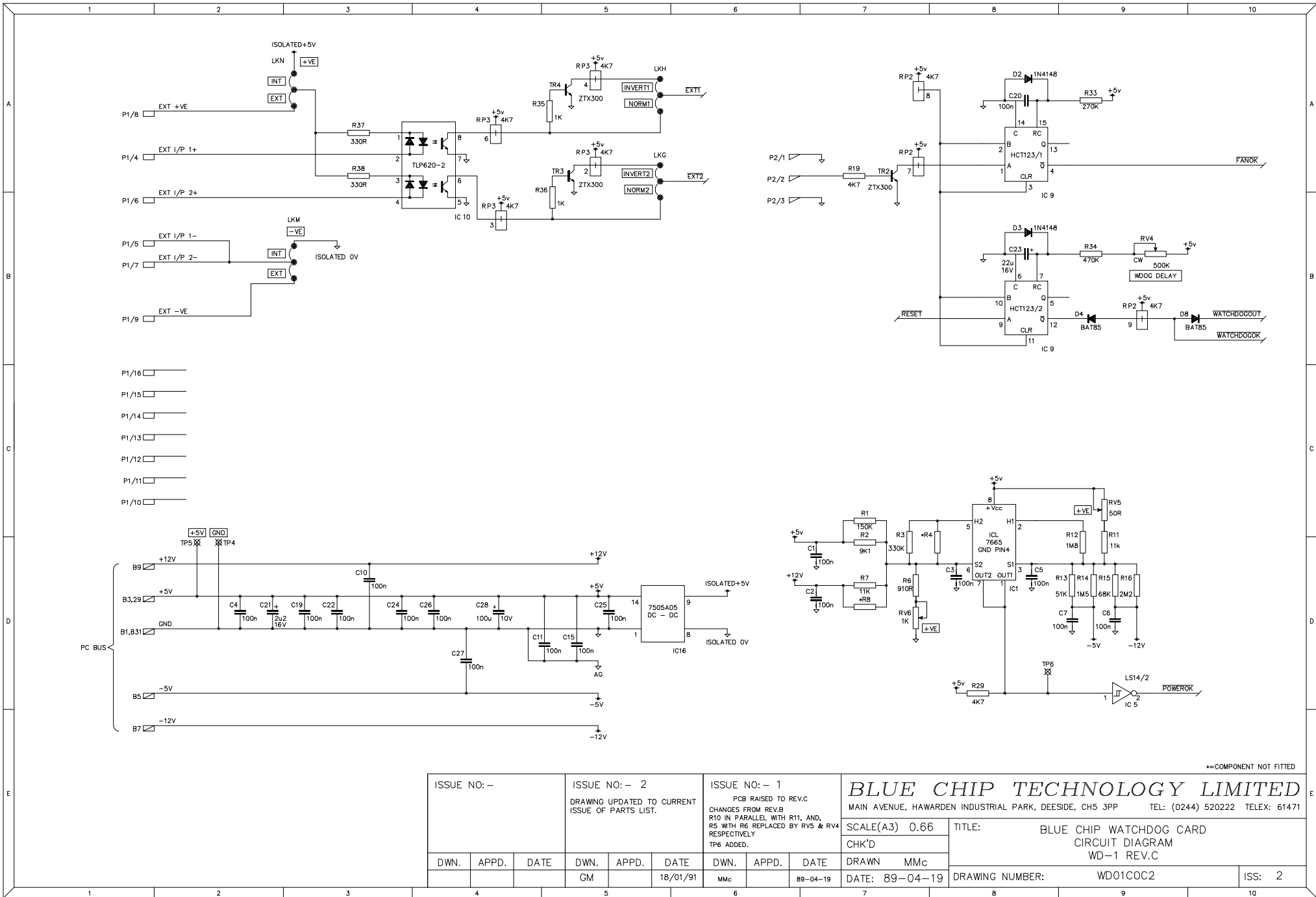

Fig.6.5 Remote level inputs with INPUT1 non-inverting and INPUT2 inverting

LINK	FUNCTION	POSITION
LKN	INTERNAL +5V OPTO SOURCE	EXT
LKM	INTERNAL 0V OPTO SOURCE	EXT
LKH	NON-INVERTING LEVEL INPUT	NON INV
LKG	INVERTING LEVEL INPUT	INV

Fig.6.6 Link settings on WD-1 card for Fig 6.5 setup



ISSUE NO: -			ISSUE NO: - 2 DRAWING UPDATED TO CURRENT ISSUE OF PARTS LIST.			ISSUE NO: - 1 PCB RAISED TO REV.C CHANGES FROM REV.B R10 IN PARALLEL WITH R11, AND, R5 WITH R6 REPLACED BY RV5 & RV4 RESPECTIVELY TP6 ADDED.		
DWN.	APPD.	DATE	DWN.	APPD.	DATE	DWN.	APPD.	DATE
			GM		18/01/91	MMc		89-04-19

BLUE CHIP TECHNOLOGY LIMITED
 MAIN AVENUE, HAWARDEN INDUSTRIAL PARK, DEESIDE, CH5 3PP TEL: (0244) 520222 TELEX: 61471

SCALE(A3) 0.66	TITLE: BLUE CHIP WATCHDOG CARD CIRCUIT DIAGRAM WD-1 REV.C
CHK'D	
DRAWN MMc	
DATE: 89-04-19	DRAWING NUMBER: WD01C0C2
	ISS: 2