

SIO-2

2 Channel Serial Communications Board



User Manual

SIO-2

User Manual

Document Part N°	0127-0001
Document Reference	0127-0001.Doc
Document Issue Level	0.6

Manual covers PCBs identified SIO-2 Rev. C

All rights reserved. No part of this publication may be reproduced, stored in any retrieval system, or transmitted, in any form or by any means, electronic, mechanical, photocopied, recorded or otherwise, without the prior permission, in writing, from the publisher. For permission in the UK contact Blue Chip Technology.

Information offered in this manual is correct at the time of printing. Blue Chip Technology accepts no responsibility for any inaccuracies. This information is subject to change without notice.

All trademarks and registered names acknowledged.

Blue Chip Technology Ltd.
Chowley Oak, Tattenhall
Chester, Cheshire
CH3 9EX.
Telephone : 01829 772000 Facsimile : 01829 772001.

Amendment History

Issue Level	Issue Date	Author	Amendment Details
0.5	12.05.89	L.P.	First approved issue.
0.6		SEJ	Update window front cover and logo. See ECN 98/083

OUTLINE DESCRIPTION	1
1.0 SPECIFICATIONS	2
1.1 Electrical Specification	2
1.2 Physical Specification	2
Electromagnetic Compatibility (EMC).....	3
EMC Specification	4
2.0 START-UP GUIDE	5
2.1 Computer Type	5
2.2 Backing up the Software Disk.....	5
2.3 Selecting the Correct Comms Port Addresses	6
2.4 Installing the card.....	7
2.5 Making the Right Connections	8
2.6 The Software Disk.....	8
3.0 CONNECTING CHANNEL A AND B	9
3.1 Connecting to a Serial Printer.....	9
3.2 Connecting to a Modem	9
3.3 Connecting to Another SIO-2 Card	10
3.4 Connecting a Mouse.....	10
4.0 CHANNEL B ALTERNATIVE INTERFACES.....	11
4.1 RS422 Full Duplex Mode	11
4.2 RS485 Half Duplex Mode.....	11
4.3 RS485 Multi-Drop Network Mode	12
4.4 20 Milliampere Current Loop Mode.....	12
5.0 THE SIO-2 AND SOFTWARE	13
6.0 COMMERCIAL DATA ACQUISITION PACKAGES	13
APPENDIX A	15
Blue Chip Technology SIO-2 Rev C	15
APPENDIX B	16
Standard Port Allocations for PC Serial.....	16
Ports on LKA or LKB	16
APPENDIX C	17

Contents

Standard Port Allocations for PC Serial.....	17
Ports on LKA or LKB	17
APPENDIX D	18
Channel A RS232 Only	18
APPENDIX E	19
A D25 Pin to D9 Pin Adapter DTE	19
APPENDIX F.....	20
Channel B RS232/422/485/Current Loop.....	20
APPENDIX G	21
Channel B R232 Full Duplex Mode	21
APPENDIX H	22
Connecting Another DTE Device to the SIO-2 Channel B A Null Modem Cable	22
APPENDIX I.....	23
Channel B 20mA Current Loop Mode	23
APPENDIX J	24
Current Loop Full Duplex Connection to Another SIO-2	24
APPENDIX K	25
SIO-2 Current Loop Half Duplex Point to Point Connection to Another SIO-2.....	25
APPENDIX L.....	26
Channel B RS422/485 Full Duplex Mode	26
APPENDIX M.....	27
Channel B RS422 Full Duplex Connections	27
to Another SIO-2.....	27
APPENDIX N	28
Channel B RS485 Half Duplex Mode	28
(Multi Drop Mode)	28
APPENDIX O	29

Contents

RS485 Half Duplex Connections to Another SIO-2.....	29
APPENDIX P	30
RS485 Multidrop Network up to 32 SIO-2 Cards.....	30
can be Connected	30
APPENDIX Q	31
Interrupt Link Setting for Channels A and B.....	31
APPENDIX R	32
PC/XT/AT Port Map	32
I/O Address Map	32
APPENDIX S	33
PC/XT Interrupt Map	33
APPENDIX T.....	34
AT Interrupt Map.....	34
APPENDIX V	35
SIO2TEST.BAS Test Connectors.....	35
APPENDIX W	36
Current Loop Simplex Connections to Another SIO-2.....	36
Overview	37

OUTLINE DESCRIPTION

The SIO-2 card allows serial communications between computers, printers, plotters, screen, PID controllers, instruments and any other device with a serial interface.

The first channel is RS232 with programmable baud rate and word format. The second channel is link selectable as either RS232, RS422/485 (full duplex, half duplex, multi-drop) or 20mA current loop. This gives compatibility with most standard serial interchange formats.

The SIO-2 is designed to provide a flexible solution to the problems of interfacing a PC or compatible with the following standards:

- EIA RS232/V24 full or half duplex
- EIA RS422 full duplex
- EIA RS485 full duplex multi-drop
- EIA RS485 half duplex multi-drop
- 20 Milliampere current loop full duplex

There are two channels designated A and B.

Channel A provides a normal RS232 type comms port and is connected to a 9 pin Cannon D range connector on the rear panel.

The pin out of this connector is to IBM 9 pin Serial standard and is configured as a DTE device.

Channel B provides a normal RS232 interface on the standard pins of a 25 way D connector but can also be selected to provide current loop, RS422 and RS485 operation which all appear on different pin outs to provide some protection from incorrect operation of the card. Channel B is also configured as a DTE device.

A full set of connection details for every mode of operation appears in the Appendix.

If installing the SIO-2 card in an Amstrad 1512 or 1640 it may be necessary to remove the bottom retaining screw on the 25 way D type connector. This is due to a non-IBM standard back panel on the Amstrad.

1.0 SPECIFICATIONS

1.1 Electrical Specification

Number of Channels	2
Interface Standards	Channel A RS232
	Channel B RS232
	RS422
	RS485
	20mA Loop

Power requirement	5V D.C. @ 150mA
Power Dissipation	500mW

1.2 Physical Specification

Height	107mm
Width	15mm
Depth	132mm

Electromagnetic Compatibility (EMC)

This product meets the requirements of the European EMC Directive (89/336/EEC) and is eligible to bear the CE mark.

It has been assessed operating in a Blue Chip Technology Icon industrial PC. However, because the board can be installed in a variety of computers, certain conditions have to be applied to ensure that the compatibility is maintained. It meets the requirements for an industrial environment (Class A product) subject to those conditions.

- The board must be installed in a computer system which provides screening suitable for the industrial environment.
- Any recommendations made by the computer system manufacturer/supplier must be complied with regarding earthing and the installation of boards.
- The board must be installed with the backplate securely screwed to the chassis of the computer to ensure good metal-to-metal (i.e. earth) contact.
- Most EMC problems are caused by the external cabling to boards. It is imperative that any external cabling to the board is totally screened, and that the screen of the cable connects to the metal end bracket of the board and hence to earth. It is recommended that round screened cables with a braided wire screen are used in preference to those with a foil screen and drain wire. Use metal connector shells which connect around the full circumference of the screen; they are far superior to those which earth the screen by a simple "pig-tail". Standard ribbon cable will not be adequate unless it is contained wholly within the cabinetry housing the industrial PC.
- Ensure that the screen of the external cable is bonded to a good RF earth at the remote end of the cable.

Failure to observe these recommendations may invalidate the EMC compliance.

Warning
This is a Class A product. In a domestic environment this product may cause radio interference in which case the user may be required to take adequate measures.

EMC Specification

A Blue Chip Technology Icon industrial PC fitted with this card meets the following specification:

Emissions:	EN 55022:1995	
	Radiated	Class A
	Conducted	Class A & B
Immunity:	EN 50082-2:1995 incorporating	
	Electrostatic Discharge	IEC 801-2:1991 Performance Criteria A
	Radio Frequency Susceptibility	ENV 50140:1993 Performance Criteria A
	Fast Burst Transients	IEC 801-4:1988 Performance Criteria A

2.0 START-UP GUIDE

2.1 Computer Type

The SIO-2 Communications card is designed to work with all correctly engineered PC compatible computers that can provide one standard 8 bit IBM PC compatible I/O slot.

If your machine has two processor clock speed options we suggest that you perform the installation tests of the SIO-2 with the machine in slow speed mode.

Once correct operation of the card has been established the perform the same tests at the higher clock rate.

Unfortunately, although Blue Chip Technology makes every effort to test its products in a wide range of machines, we cannot guarantee that every so called "PC compatible" has correct I/O slot timing.

Some of the latest 80386 based machines have a facility in their CMOS RAM set-up program to adjust the number of wait states used by the machine when accessing the I/O slot.

2.2 Backing up the Software Disk

The SIO-2 card has been supplied with a floppy disk containing software demonstrations and example drivers for your use.

It is important that you make an immediate backup of this disk and store it in a suitably cool dry place.

The disk is not copy protected in any way and you are free to make as many backup copies as you like for your own departments use.

The disk can be copied onto blank floppy diskette of the same type with the MS-DOS command DISKCOPY A: A: on a single drive, or DISKCOPY A: B: on a twin drive machine.

If you wish to copy the files to a fixed disk (normally drive C) use the command MD\SIO-2 to make a suitable directory on drive C:, type CD\SIO-2 followed by a carriage return, put the SIO-2 floppy disk in drive A: and type COPY A:*. *C: followed by a carriage return.

This will copy all the files from the SIO-2 disk into the correct directory on drive C:.

2.3 Selecting the Correct Comms Port Addresses

before placing the SIO-2 into your computer I/O slot it is necessary to establish and set the correct addresses in the PC port map for the card to use.

The Sio-2 has two channels each of which required a different address to be set. Channel A is connected to the 9 way D type connector on the back panel and provides 1 standard PC serial comms port.

The address for channel A is controlled by the mini-dip header LKA on the upper left hand side of the board.

Channel B is connected to the 25 way D type connector on the back panel and provides 1 serial port which can work as a normal PC serial comms port in RS232 and current loop modes or as a special comms port on RS422//485 modes.

The port address for channel B is controlled by the mini-dip header LKB on the lower left hand side of the board.

Appendices B and C give example link settings for the normal IBM PC serial ports COM1 and COM2 plus the usual ports unofficially allocated by software and hardware manufacturers to COM3-COM8.

The SIO-2 card is normally issued from the factory with channel A set to COM1 and channel B set to COM2. It is quite likely that your computer will already have at least one serial port built into it; if so then this will usually be occupying the COM1 port address.

There are two solutions to this contention problem:

- i. Disable the COM1/COM2 on your PC. See your PC manual for instructions.
- ii. Change the I/O port addresses (and possibly interrupts) on the SIO-2 card. See Appendices B, C and Q. Ensure that no other cards or system devices are set to the same port address or interrupt. Multiple SIO-2 cards can use the same interrupts provided that the software is written to support this.

Extra mini-dip green links are provided with your package to enable other address selections to be set.

2.4 Installing the card

If this is the first time that you have installed a peripheral card in your PC, you should refer to the instructions in the hardware guide supplied with your machine for information on how to remove the cover and install devices into the I/O channel slot.

The SIO-2 may be placed in any available slot of your PC compatible computer provided that there is no restriction placed upon the slot by the manufacturer of the machine.

2.5 Making the Right Connections

Channel A of the SIO-2 is intended for RS232 DTE operation only.

Channel B is supplied with its links set for RS232 DTE operation. If you wish to use any of the other options on the channel B then you should follow the link position and connection diagrams supplied in the Appendix and read the appropriate section of the manual.

The type of connection you will need to make to channel B of the SIO-2 will depend upon the interface on the peripheral device you wish to connect to.

2.6 The Software Disk

The card can be used as COM1 or COM2 in full duplex RS232/RS422 and current loop modes from most existing software, but the RS485 half duplex mode requires the user to program the board to switch transmission on and off and for this mode of knowledge of programming in any of the PC languages is required.

The software disk supplied with the SIO-2 contains a number of example ways of driving the card from various languages.

3.0 CONNECTING CHANNEL A AND B

Channel A appears on the 9 way D connector on the rear panel as standard IBM PC AT style RS232 serial port.

Channel B appears on the 25 way D connector on the rear panel as a standard IBM PC style RS232 and current loop port and also has RS422 and RS485 capability.

Both channels can be used to connect various peripherals such as printers, modems and mouse type pointing devices.

3.1 Connecting to a Serial Printer

When IBM designed the PC they considered it to be a data TERMINAL and so the serial port design is treated as a TERMINAL or DTE device. The consequence of this is that to connect it to another peripheral such as a printer you must reverse the signals between the two devices.

When connecting a serial printer it is necessary to remember to connect the printer busy line (normally pin 20 on the 25 way D connector on the printer) to the DSR, CTS and DCD connections on the appropriate connector on the PC.

The wiring diagram for a suitable cable appears in Appendix H.

3.2 Connecting to a Modem

The connections for this type of equipment should normally be direct signal to signal and in the case of the WS4000 the following pins will make the modem behave correctly.

25 way D connector

Pin	2	Transmit data	TX
Pin	3	Receive data	RX
Pin	8	Data carrier detect	DCD
Pin	20	Data terminal ready	DTR
Pin	7	Digital ground	

If you wish to use a modem on channel A the details of a D25 to D9 converter cable appear in Appendix E. Alternatively, you can create a special direct cable from the information in the pinout details.

3.3 Connecting to Another SIO-2 Card

The null modem cable concept (Appendix H) can be used again for this connection and it should be remembered that for cable lengths of over 50 feet another interface such as RS422/485 should be considered.

3.4 Connecting a Mouse

We recommend the Microsoft Serial Mouse for use with the SIO-2. This comes with an adapter for both D9 and D25 connections. There are other mice on the market and provided they are designed to work through a standard IBM PC serial port then they should present no problem.

If you do experience problems, please refer to the supplier of the mouse first before contacting us.

Blue Chip Technology can supply a complete range of printers, mice, plotters and external terminals etc. For more details contact our Sales Department.

4.0 CHANNEL B ALTERNATIVE INTERFACES

4.1 RS422 Full Duplex Mode

To set the SIO-2 for RS422 full duplex mode refer to Appendix L for the connections and link positions for LKD. Appendix A contains a complete drawing of the SIO-2 card detailing the locations of the various links on the board.

It is important to remember to use good quality shielded twisted pair cable for this interface especially if a high baud rate (i.e. :- greater than 2400) is being used.

The line drive and receiver interface device used for this mode if the 75176 and in this mode IC9 transmits data and IC8 receives it.

4.2 RS485 Half Duplex Mode

N.B. Remember when using this mode to fit good quality shielded twisted pair cable and also to install the links to enable the 100ohm terminating resistors in the cards at the ends of the cable. See Appendix L.

Communication on a single twisted pair can be achieved with RS485 half duplex mode.

Appendix N details the link settings and connections for this mode.

IC9 is used alone to provide this interface and consequently it must be switched from receive to transmit and back again to receive when the user wishes to send a message.

The signal to switch the Tx and Rx can be selected as DTR or OUT1 from the channel BB 164550 device. Link C allows you to select the appropriate signal. By setting the selected signal to a high state IC9 is put into the Receive mode.

RS485 half duplex is very useful mode of operation for data acquisition and message switching between PC based equipment Appendix O details how to connect two SIO-2 cards back to back in this mode.

4.3 RS485 Multi-Drop Network Mode

Appendix P details how to couple up multiple SIO-2 cards to form a multi-drop network which is capable of communication at distances of up to 1 kilometre dependent upon baud rate.

Please remember that the protocol for using this mode of operation is totally dependent upon the user designing software to avoid message collision and provide some form of packet based addressing system.

N.B. Remember when using this mode to fit good quality shielded twisted pair cable and also to install the links (LKD5 and LKD6) for the 100ohm terminating resistors in the cards at the ends of the cable. See Appendix L.

4.4 20 Milliampere Current Loop Mode

Appendix I details the correct link settings and connections for current loop operation.

IC13 and IC14 provide the driver and receiver for this mode. The pin out of the current loop mode has been designed to be identical to that used on the IBM PC serial adapter.

Thus any cable designed to use this interface card should work properly when plugged into the SIO-2.

Appendix J and K detail the correct connections for full and half duplex operation in this mode.

Appendix W details the correct connections for simplex operation in this mode.

5.0 THE SIO-2 AND SOFTWARE

How you drive the SIO-2 depends totally upon the type of application you propose to use it for. If the card is set-up as COM1 and COM2 then the channels can be driven from DOS with the exception that half duplex RS485 requires some extra programming in this mode.

It should be remembered that under MS-DOS 3.2 and below there is no software support provided by the operating system for more than the first two serial ports on the system (COM1 and COM2).

Other operating systems such as IBM PC-DOS and 386 and PC/MOS386 do allow the user to make use of more than 2 serial ports for the connection of extra user terminals and other printers etc. and it is expected that OS/2 will do the same.

Many language compilers have the facility to use add on communications toolkits such as the Greenleaf comms library for 'C' etc.

The card uses the national Semiconductor NS16450N device which is functionally equivalent to the original Intel 8250 device used on the early PC serial cards and is the same chip used by most PC manufacturers today.

The floppy disk which accompanies the card contains a number of programs as examples of how to drive the COM ports from different languages.

There is a file called README.TXT on the disk which details the latest updates to the programs.

6.0 COMMERCIAL DATA ACQUISITION PACKAGES

The Blue Chip Technology SIO-2 can be used with almost any data acquisition package that can transmit and receive information directly to and from a PC serial port, or any package that has driver support for the INTEL 8250 or National Semiconductor NS164450chip.

The board is installable as a standard serial PORT in the following packages:

Blue Chip Technology SCAN1000

ASYST by Macmillan Software
Labtech notebook
LOTUS Measure
LOTUS Symphony
Almost any PC based communications package

For more details about these packages and other PC data acquisition software, please contact Blue Chip Technology.

Whilst every effort has been taken to ensure that the information provided is accurate, Blue Chip Technology cannot assume responsibility for any errors in this manual or their consequences. Should any errors in this manual be detected, the company would greatly appreciate being informed of them. A policy of continuous product development is operated, resulting in the contents of this document being subject to change without notice.

APPENDIX A

Blue Chip Technology SIO-2 Rev C

APPENDIX B

Standard Port Allocations for PC Serial Ports on LKA or LKB

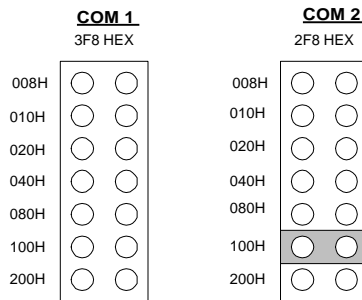

N.B. All links removed

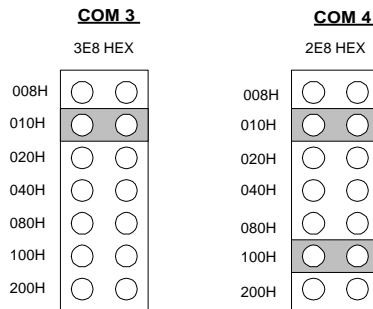

APPENDIX C

Standard Port Allocations for PC Serial Ports on LKA or LKB

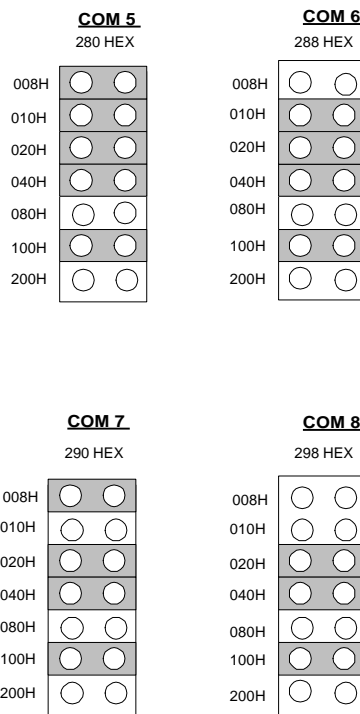

(N.B. ALL LINKS VIEWED WITH CONNECTORS ON RHS)

APPENDIX D

Channel A RS232 Only

D9 Connections

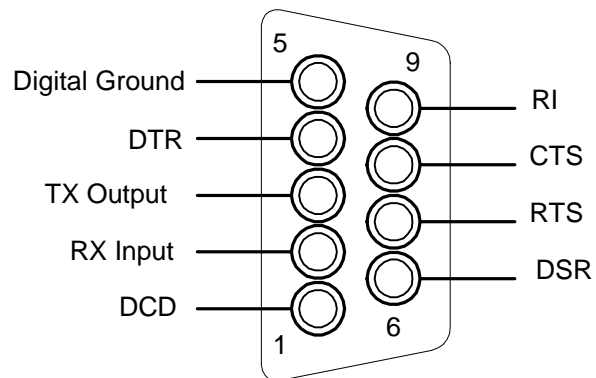

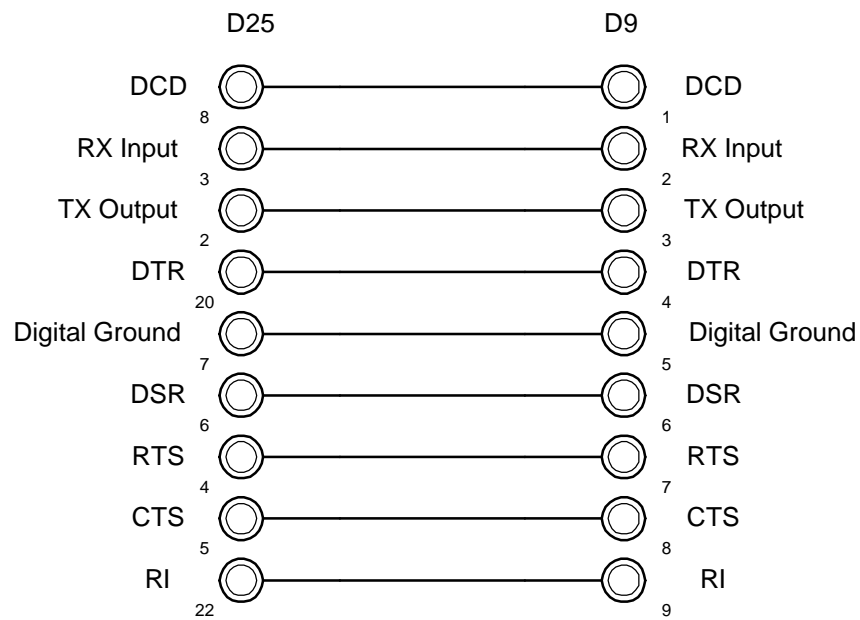
APPENDIX E**A D25 Pin to D9 Pin Adapter DTE**D25 And D9 Pin Connections

APPENDIX F

Channel B RS232/422/485/Current Loop

D25 Connections

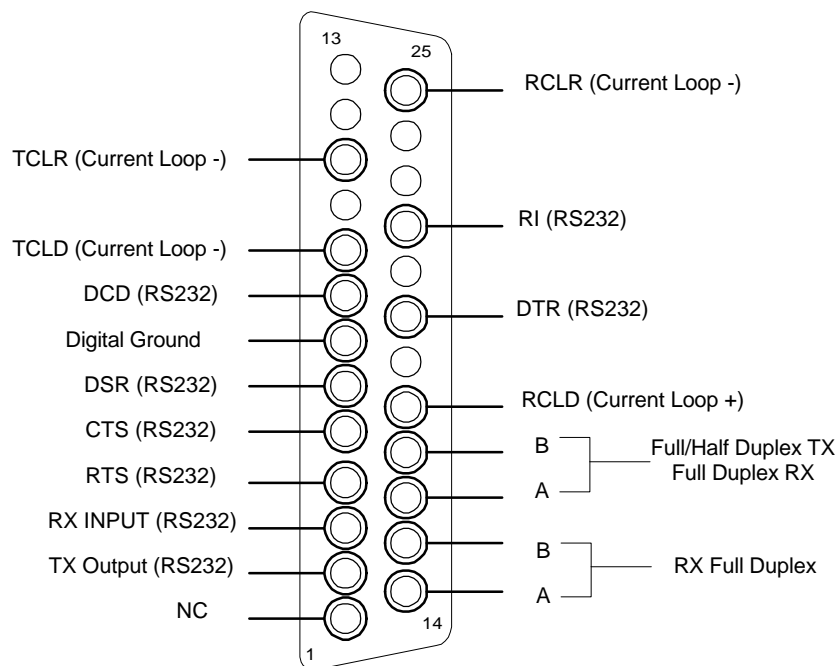

APPENDIX G

Channel B R232 Full Duplex Mode

D25 Connections

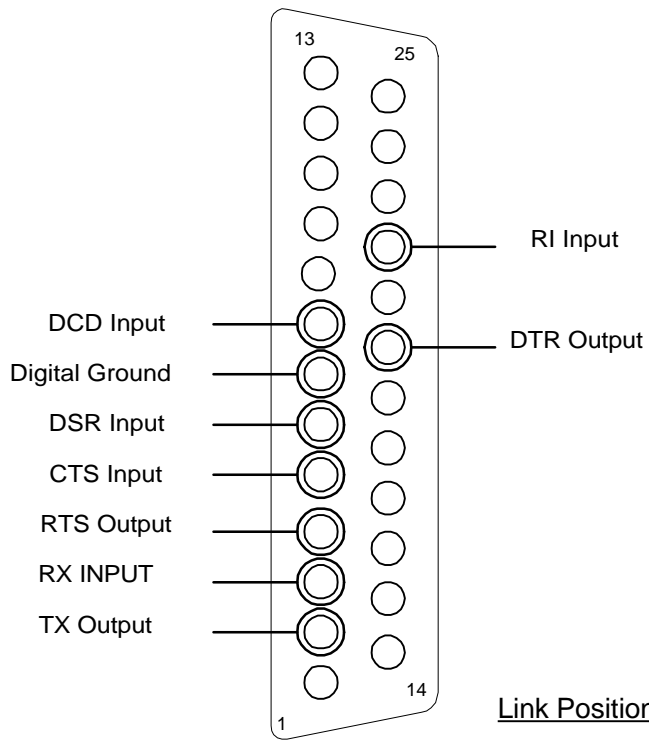

Link Positions

LKD

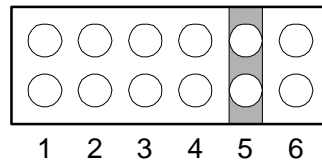

APPENDIX H

Connecting Another DTE Device to the SIO-2 Channel B A Null Modem Cable

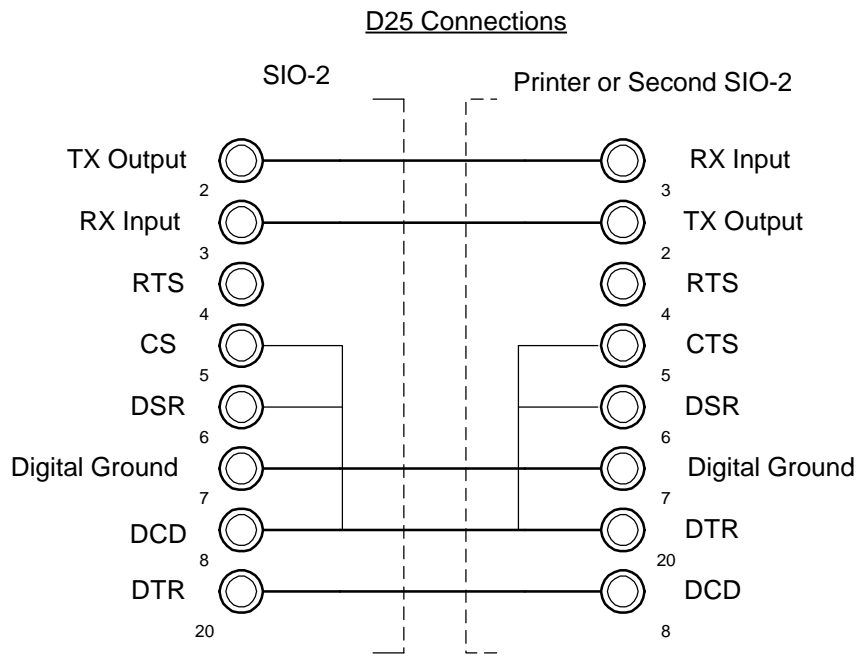

APPENDIX I

Channel B 20mA Current Loop Mode

D25 Connections

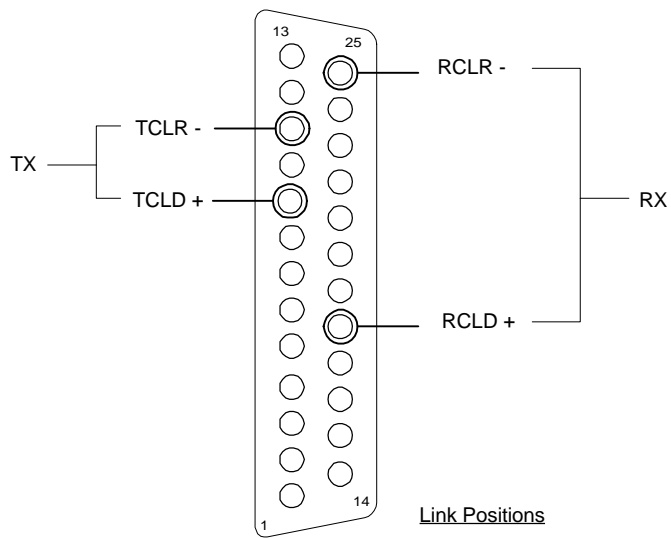

Link Positions

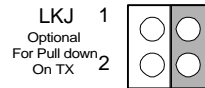
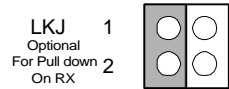
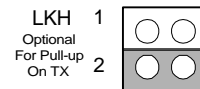
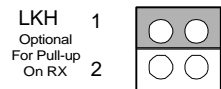
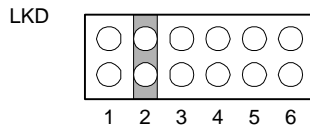

APPENDIX J

Current Loop Full Duplex Connection to Another SIO-2

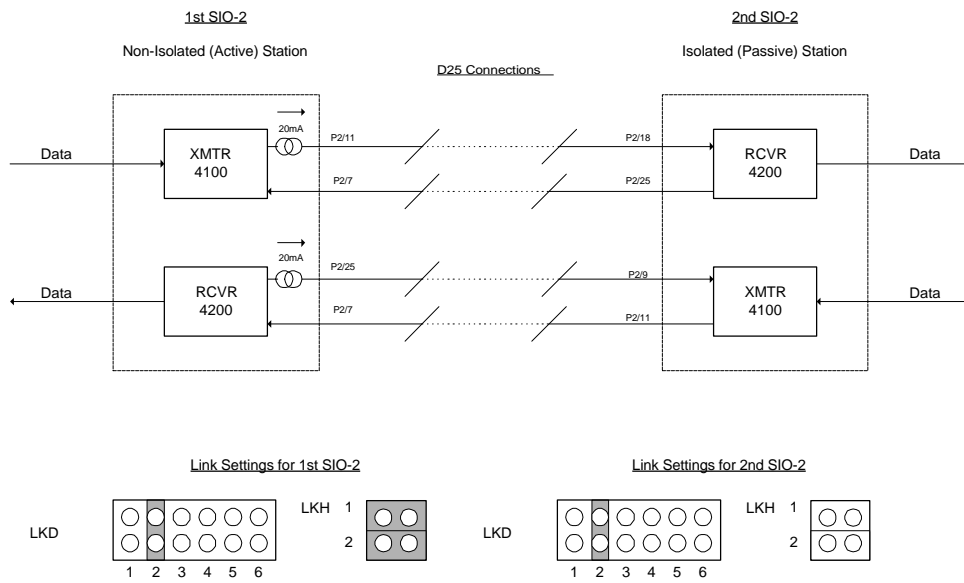

APPENDIX K

SIO-2 Current Loop Half Duplex Point to Point Connection to Another SIO-2

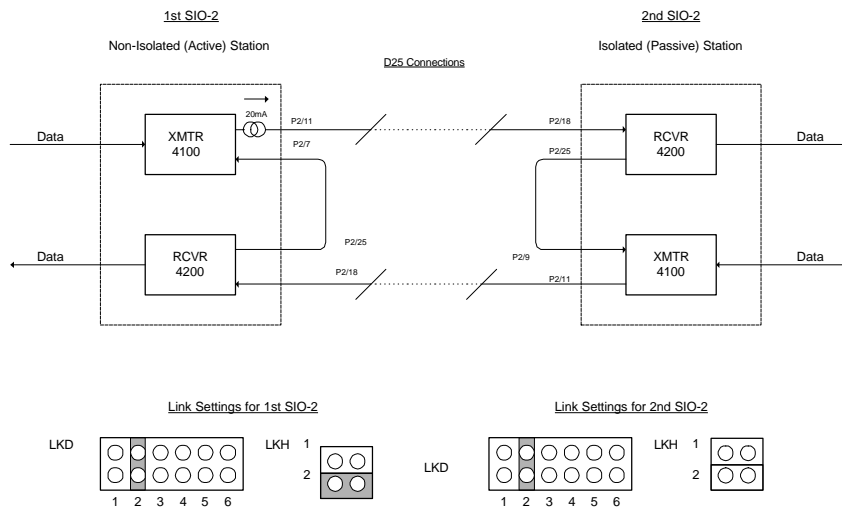

APPENDIX L

Channel B RS422/485 Full Duplex Mode

D25 Connections

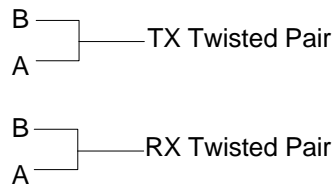
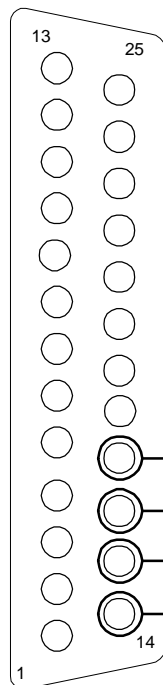

Link Positions

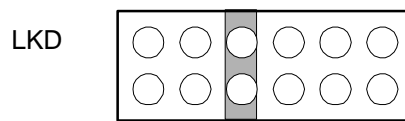

(N.B. LKD 5/6 CAN BE FITTED TO ENABLE THE 100R TERMINATOR RESISTORS IN THE RX AND TX LINES RESPECTIVELY)

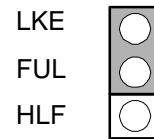

N.B. LKC NOT APPLICABLE

APPENDIX M

Channel B RS422 Full Duplex Connections to Another SIO-2

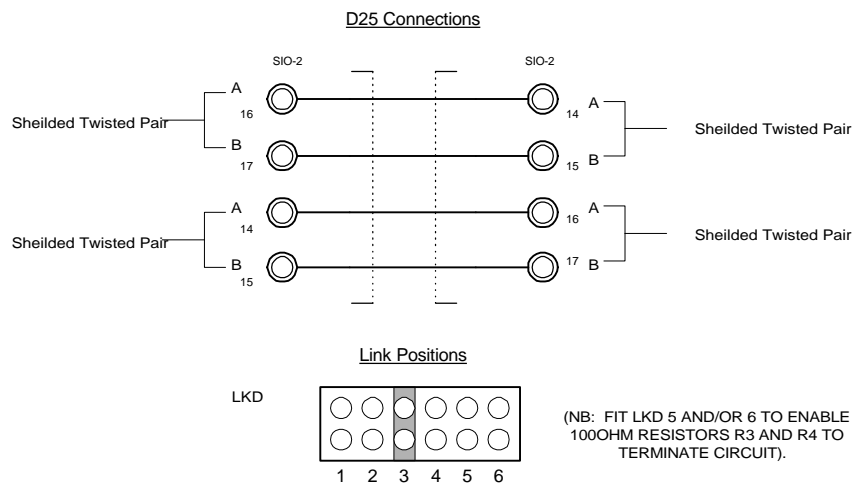

APPENDIX N

Channel B RS485 Half Duplex Mode (Multi Drop Mode)

D25 Connections

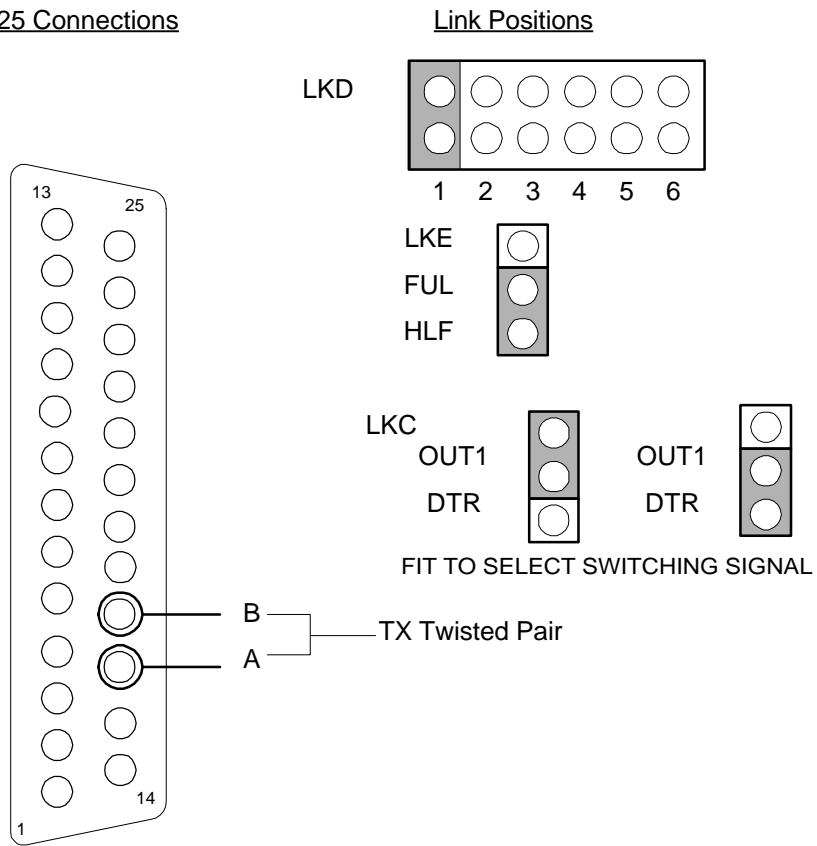

APPENDIX P

RS485 Multidrop Network up to 32 SIO-2 Cards can be Connected

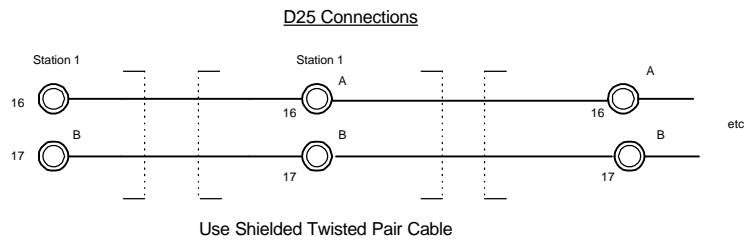

Link Positions All Both SIO-2 Cards

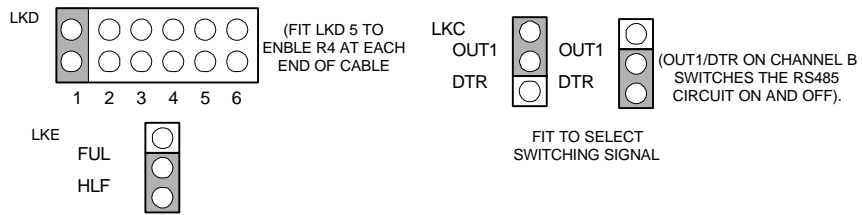

APPENDIX Q

Interrupt Link Setting for Channels A and B

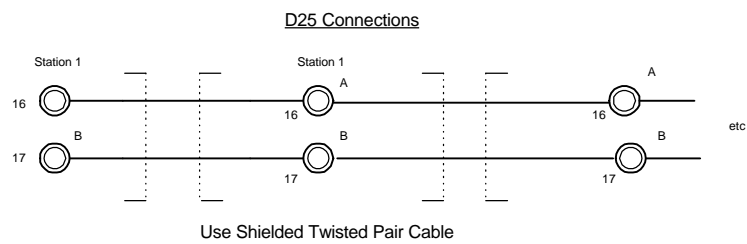

Link Positions All Both SIO-2 Cards

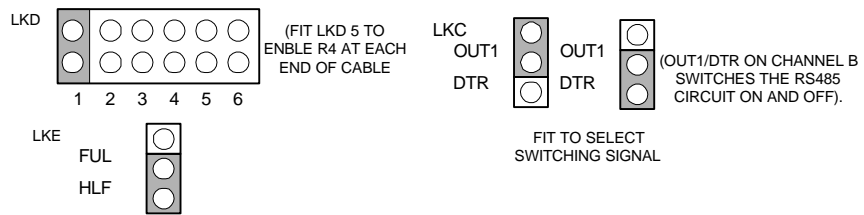

APPENDIX R

PC/XT/AT Port Map I/O Address Map

Address

000-01F	DMA controller 1, 8237A-5
02-03F	Interrupt controller 1, 8259A
040-05F	Timer, 8254
060-06F	Keyboard controller, 8742; control port B
070-07F	RTC and CMOS RAM, NMI Mask (Write)
080-09F	DMA Page Register (Memory Mapper)
0A0-0BF	Interrupt controller 2, 8259
0F0	Clear NPX (80287) busy
0F1	Reset NPX, 80287
0F8-0FF	Numeric Processor Extension, 80287
1F0-1F8	Hard disk drive controller
200-207	Reserved
278-27F	Reserved for Parallel Printer Port 2
2F8-2FF	Reserved for Serial Port 2
300-31F	Reserved
360-36F	Reserved
378-37F	Parallel Printer Port 1
380-38F	Reserved for SDLC Communications, Bisynchronous 2
3A0-3AF	Reserved for Bisynchronous 1
3B0-3BF	Reserved
3C0-3CF	Reserved
3D0-3DF	Display Controller
3F0-3F7	Diskette Drive Controller
3F8-3FF	Serial Port 1

APPENDIX S

PC/XT Interrupt Map

Number	Usage
NMI	Parity
0	Timer
1	Keyboard
2	Reserved
3	Asynchronous Communications (Secondary) SDLC Communications
4	Asynchronous Communications (Primary) SDLC Communications
5	Fixed Disk
6	Diskette
7	Parallel printer

APPENDIX T

AT Interrupt Map

Level	Function
Microprocessor NMI	Parity or I/O Channel Check
Interrupt Controllers	
CTLR 1 CTLR 2	
IRQ 0	Timer Output 0
IRQ 1	Keyboard (Output Buffer Full)
IRQ 2	Interrupt from CTLR 2
IRQ 8	Realtime Clock Interrupt
IRQ 9	Software Redirected to INT 0AH (IRQ 2)
IRQ 10	Reserved
IRQ 11	Reserved
IRQ 12	Reserved
IRQ 13	Coprocessor
IRQ 14	Fixed Disk Controller
IRQ 15	Reserved
IRQ 3	Serial Port 2
IRQ 4	Serial Port 1
IRQ 5	Parallel Port 2
IRQ 6	Diskette Controller
IRQ 7	Parallel Port 1

APPENDIX V

SIO2TEST.BAS Test Connectors

Test connectors to operate with SIO2TEST.BAS can be made up by making the following links on dummy connectors.

D9	D25
2-3	2-3
4-6	4-5
7-8	6-8-20
	7-25
	14-16
	15-17
	18-11

APPENDIX W

Current Loop Simplex Connections to Another SIO-2

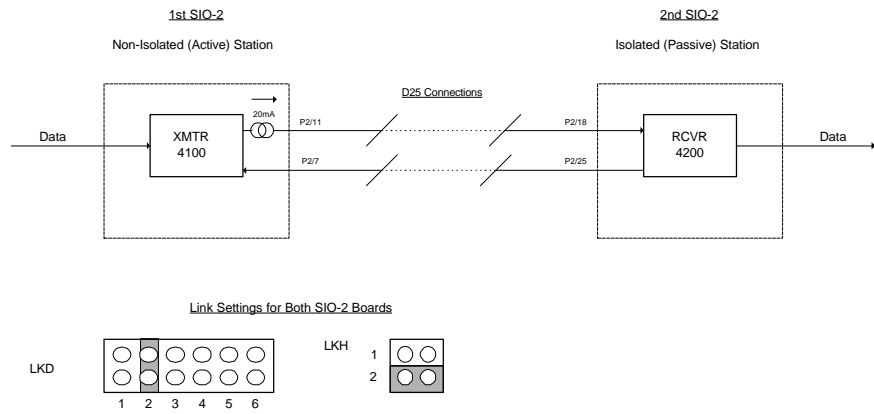

Overview

RS422/RS485

Most people have heard of RS232C as an interface standard used in computer communications. The RS232C standard has been successful in uniting the industry to a common interface, but it suffers from several limitations:

1. Data transmission rate.
2. Transmission distance.
3. The need to connect the ground together (unbalanced circuits).

RS422 was established in 1975. It overcomes the above problems and provides a fast, reliable balanced interface. Data transmission rate is improved from 38.4 Kilobaud up to 10 Megabaud; the transmission distance is increased from 15 metres to 1 Kilometre and the circuit operates in a differential mode and does not require a common ground connection.

Note: The transmission rate and distance are mutually exclusive.

The natural progression for RS422 was for it to grow into a network communications medium. As far as point to point communications are concerned (see figure 1.) RS422 is a success due to the possible high speed and long distances. However, when the true “bus topology” network (figure 2.) was considered the standard RS422 transceivers could not cope with the possibilities of more than one transmitter being active at any one time.

Figure 1

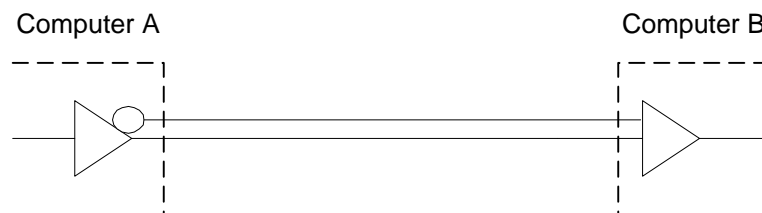
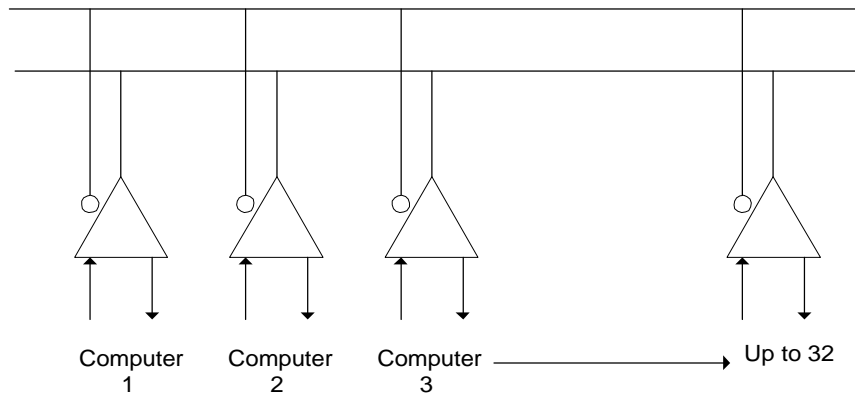

Figure 2



If this situation did occur, the RS422 drivers would probably be irreparably damaged. To overcome this the RS485 standard was established. This allows for the possibility of a transmission “collision” from any two computers without any damage occurring. The RS485 is now the industry standard for low cost Collision Sensing Multiple Access networks (CSMA) and the most popular device for implementing this circuitry is the 75176 transceiver as used on the Blue Chip Technology SIO-2.

The electrical details of the RS485 standard are:

1. Differential Drive - the two outputs are driven to opposite polarities at any one time. The maximum difference between the output pins at any time is 6 volts and the minimum is 2 volts.
2. The input can accept up to +/- 12 volts without any damage being sustained.
3. The ability to drive up to a total of 32 transceivers connected at any one instant (further transceivers can be accepted by using repeaters).
4. The receiving sensitivity is 200 millivolts difference between the inputs pins.

5. -7 volts to + 12 volts bus common mode range permits a ground difference of +/- 7 volts between devices on the bus.

Considerations

1. It is recommended that termination is applied to the devices at each end of the bus. This termination is typically 100 ohms (this is provided on the SIO-2 card and can be effected by fitting links on the card; see the manual), although it depends on the characteristic impedance of the cable being used.

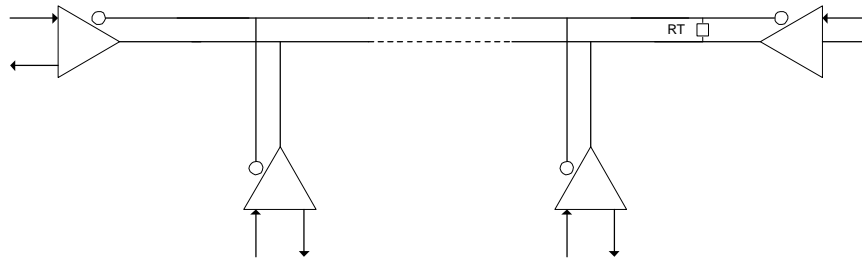

An alternative method of termination can be implemented as below:

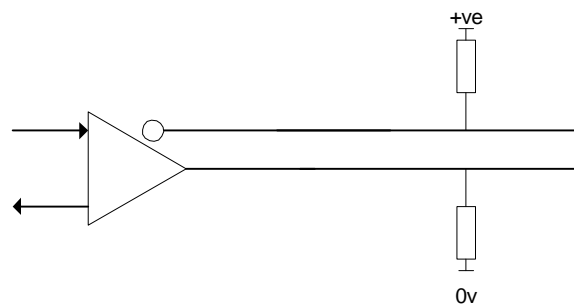

This can be effective under certain conditions but does provide a path between the power rails on the devices.

2. The layout of the bus topology is subject to a phenomenon known as “Transmission Line” effects. This can affect the signal strength at various points on the bus and if the distance from the true bus to the device is not kept as short as possible there is a distinct chance that null points (extreme) or low signal strength (more likely) will appear.

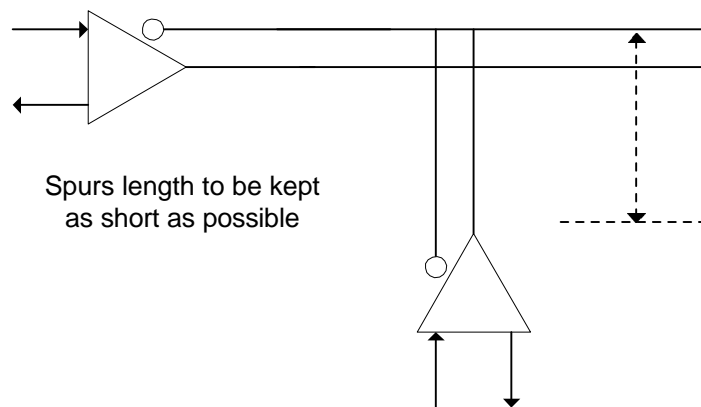

The ideal is where no spur (stub) length exists. This can be achieved by connecting the bus and the joining device at the same point.

3. Length of cable is determined by the transmission rate e.g.

Maximum Distance	Rate
1 Kilometre	100 Kilobaud
100 Metres	1 Megabaud
10 Metres	10 Megabaud

(Using 24 AWG cable).

4. The cable used can affect the operation of the bus. Typically, it should present a nominal characteristic impedance of 100 ohms to frequencies greater than 100 kilohertz and a DC series loop resistance not exceeding 240 ohms.

Whether the cable is twisted or not, screened or not, can affect the operation. Obviously, by screening the cable the noise immunity can be increased but you should consider:

- a. Where is the screen attached to - it is not advisable to connect the screen up to all devices (remember RS232 ?).
 - b. The cable to cable crosstalk within a sheath will increase.
 - c. The cable tray capacitance will increase and if excessive (depends on length of cable and value/foot) can affect performance.
The above should be considered before a network is implemented.
5. There should not be more than 7 volts difference between any two devices' ground potential on the bus. Beyond 7 volts the common mode range will be exceeded and the devices will not operate correctly. One way to operate under these conditions is by introducing an isolating transformer in the output circuitry of the transceivers.
 6. Problems can be experienced when implementing a software protocol on a 2 wire bus.

As we have stated before no two transceivers can transmit at the same time. Therefore, a mechanism must exist so that each device knows when it can transmit freely.

The most common way of operation is the "Master Slave" method. This is where one device on the network is deemed to be the Master and this device initiates all transmissions by communicating with each of the other devices in turn and offering it an opportunity to transmit. This provides a relatively simple solution but means that the Master will have a high overhead in controlling the network. Also devices needing to communicate to devices other than the Master carry a larger overhead and an additional software complication.

A more sophisticated protocol is the “Token Ring” method which works by each device knowing which device is next on the bus (ID number, not by physical location) and taking directly to it.

The communication occurs between each adjacent pair of devices and can improve the flexibility of the network but is more difficult to implement especially where devices can be switched on or off at any time.

Current Loop

This method of interfacing has been used for a relatively long time now. It has a reputation for high integrity in noisy environments and the ability to isolate the various devices within the loop. Its weakness is usually transmission rate where 9600 baud is acknowledged as high (although 19200 baud is possible) and this limits current loop to low speed activities.

The basis of the current loop interface is that rather than a voltage which is transferred between devices as with RS232, 422 and 485, a current is passed instead.

This figure shows a typical current loop circuit.

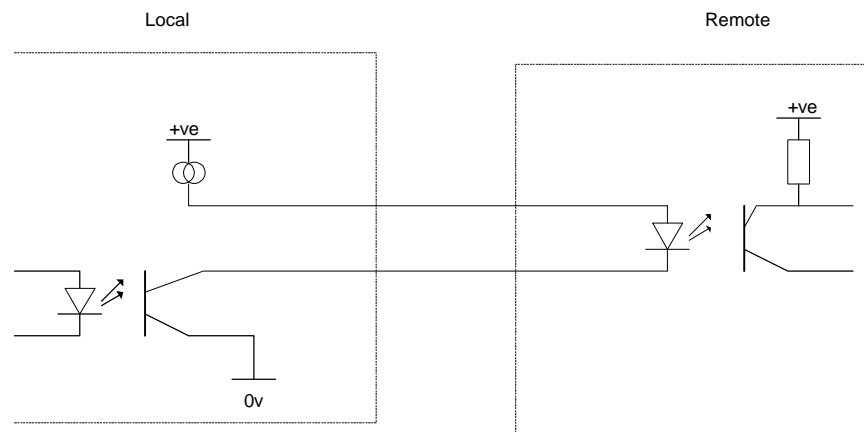

A constant current generator provides an output from the local device that is fed to the external cabling and passes through an LED (light emitting diode) at the remote device. The current is fed back to the local device and is then switched on or off to provide to modulation of the current to either produce a MARK or SPACE bit.

Considerations

1. If multiple CL devices are connected in a daisy chain arrangement, it may be necessary to fit by-pass diodes at each station in case the cable is disconnected.

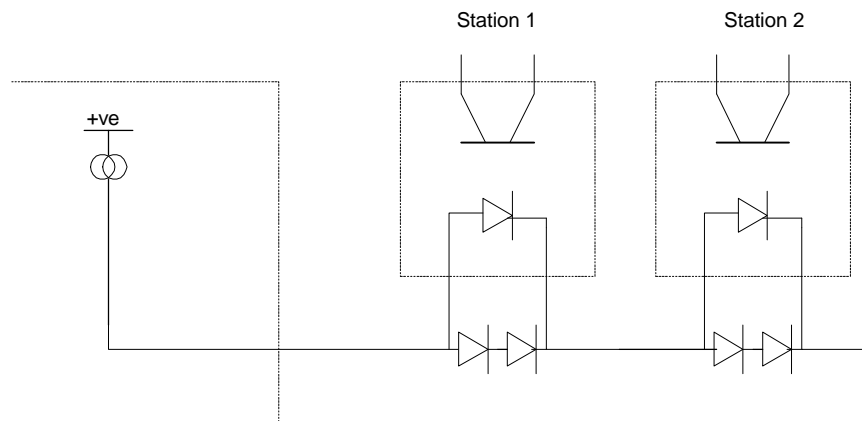

By doing so the current path is ensure at all times regardless of whether the connection to the station is made or not.

It should be remembered that the positive voltage applied at the current generator device will limit the number of series diodes (either LED or conventional).

2. The capacitance of the cable can affect the CL operation significantly. The larger the capacitance and length of the cable the lower the maximum possible transmission rate.

3. Various permutations of pull ups and pull downs can be used (especially on BCT SIO-2) to provide the current path. Basically conventional current must flow from a positive voltage to a negative voltage. This can be achieved in many ways:

